

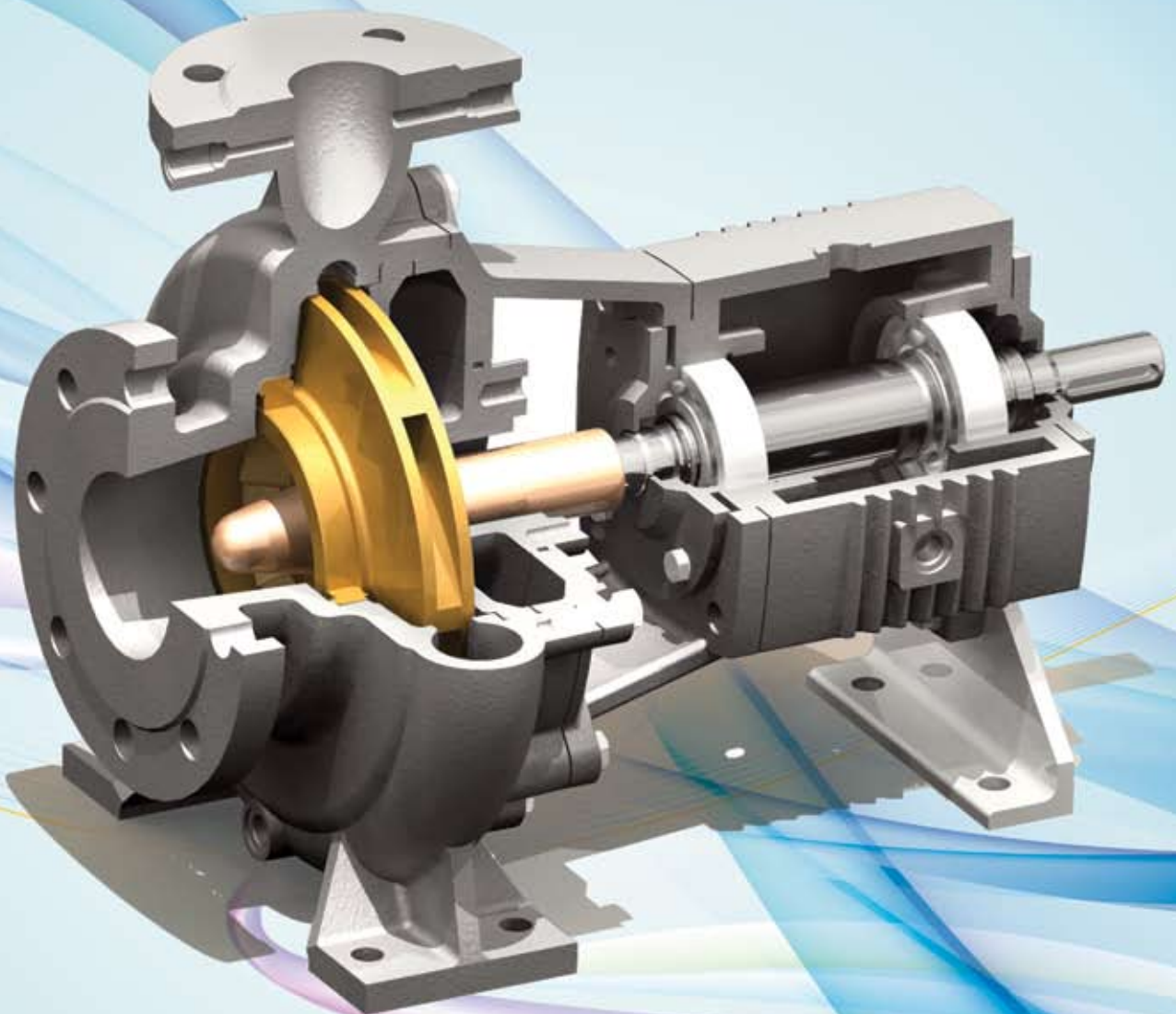

PUMP YOUR WAY TO SUCCESS



END SUCTION CENTRIFUGAL PUMPS- SCP

Catalog 2009

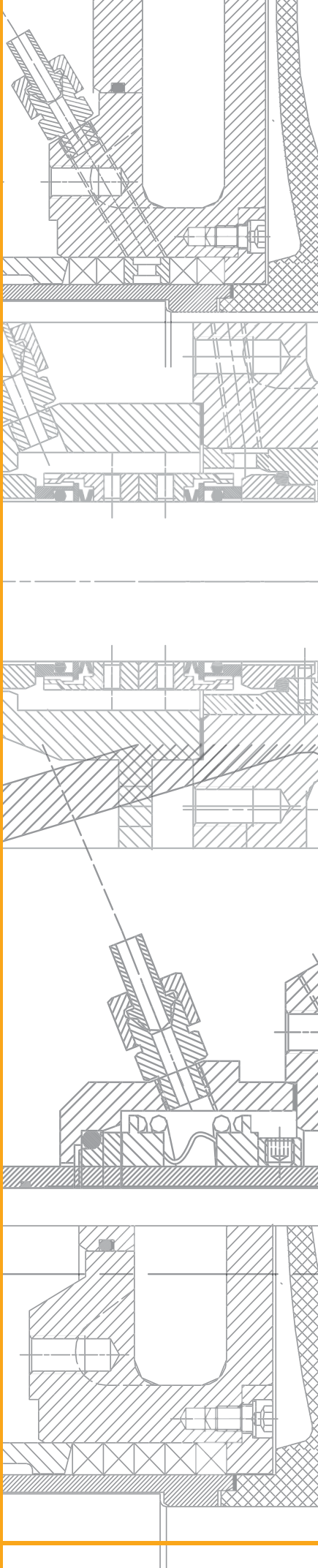

MZT Pumpi a.d is one of the leading manufacturers of industrial pumps in the region of South-East Europe. With its extensive experience of more than 60 years, justified with existence of broad product range, it continuously strives to satisfy the utmost needs of the customer.

The key elements to survive in this globalized market are flexibility towards market changes and ability to innovate-both in product designs as well as business processes. By following the worldwide development in the pump industry, our staff constantly faces with the growing challenge to keep abreast of the numerous innovations in pump designs and this is justified by having a separate R&D department.

The basic objective of MZT Pumpi is expanding the business partnerships and building the brand name of our products worldwide. All of our employees live up to our motto: "Pump your way to success".

CONTENT

GENERAL INFORMATION	4
TECHNICAL DATA - MAIN PARTS	5
TECHNICAL DATA - BEARINGS	6
TECHNICAL DATA - FLANGE CONNECTIONS	7
TECHNICAL DATA - SHAFT SEALING	8
TECHNICAL DATA - INSTALLATION DIMENSIONS	9

GENERAL INFORMATION

Application

For liquid transfer and circulation of cold and hot clean or slightly polluted water, for handling aggressive organic and inorganic liquids in the chemical and petrochemical industries.

Typical applications in:

- Municipal water supply
- The paper and cellulose industries
- Food staffs industry
- Domestic water supply
- Industrial plants
- Boiler feed and condensate systems
- Irrigation and dewatering
- General purposes and ets.

Design

Horizontal, radial split volute casing pump in back pull-out design, with radial impeller, single entry, single stage, centrifugal end-suction pump with flanged bearing frame, suitable for flexible coupling to electric motor or internal combustion engine as a driver. High operating reliability due to maintenance and service optimized parts.

Designation

Example: SCP 50-315
 Pump type SCP
 Discharge DN [mm] 50
 Nominal impeller diameter [mm] 315

Operating Range

Capacity Q: up to 2500 m³/h 700l/s
 Heads H: up to 150m
 Pump size DN 32 to 400
 Operating pressure p: up to 25 bar
 Operating temperatures t: -40 to +400



Pos.	Component	Material	Optional mat.
1.	Pump case	GG	GGG,CS,SS,DSS,SDSS,BR
2.	Impeller	GG	GGG,CS,SS,DSS,SDSS,BR
3.	Shaft	SS	SS
4.	Shaft sleeve	SS	SS,DSS,SDSS
5.	Bearing bracket	GG	GG,GGG,CS,GGG,CS,SS,DSS,
6.	Pump cover	GG	SDSS,BR

Legend:

GG - Cast iron
 GGG - Ductile iron
 CS - Cast steel
 SS - Stainless steel
 DSS - Duplex stainless steel
 SDSS - Super duplex stainless steel
 BR - Bronze

Balancing

Axial thrust is balanced by back vanes on DN > 400 and sealing gap on both sides if impeller diameter >500.

Shaft Sealing

The shaft sealing could be arranged by soft packing or mechanical seal.

In soft packing arrangements the shaft is protected by replaceable, stainless sleeve while the stuffing box is furnished with lantern ring for introduction of cooling liquid into the packing.

On special demand the pumps could be furnished with mechanical seal in accordance with the characteristics of the liquid and the operating conditions. Single mechanical seals are according EN 12756 (DIN 24960)

Conversion from the gland packing to the mechanical seal is possible without any rework on the casing cover by using the relevant replacement parts.

Back pull out design

Back pull out design is attainable on special demand. The Back Pull Out design greatly facilitates maintenance of the SCP pumps.

Forces and Moments

SCP pumps are designed for handling and moments in accordance with ISO 5199

Testing and Guarantees

- Material certificates: EN 10204
- Hydrostatic test: 150 % over nominal pressure
- Performance tests: in accordance with ISO 9906

Warranties are given within the scope of the valid delivery conditions

TECHNICAL DATA - MAIN PARTS

Wear rings

Front and back (in case of impeller dia. >500mm) renewable wear rings are furnished in order to achieve the best pump performance and ease the maintenance.

Pump case

The pump case is of rigid design with a generous wall thickness, giving good protection against erosion and corrosion.

Shaft sealing

SCP pumps can be fitted with most sealing arrangements:
-soft packing
-mechanical seal

Shaft bearing bracket

The heavy duty console with incorporated lantern assures silent and reliable operation.

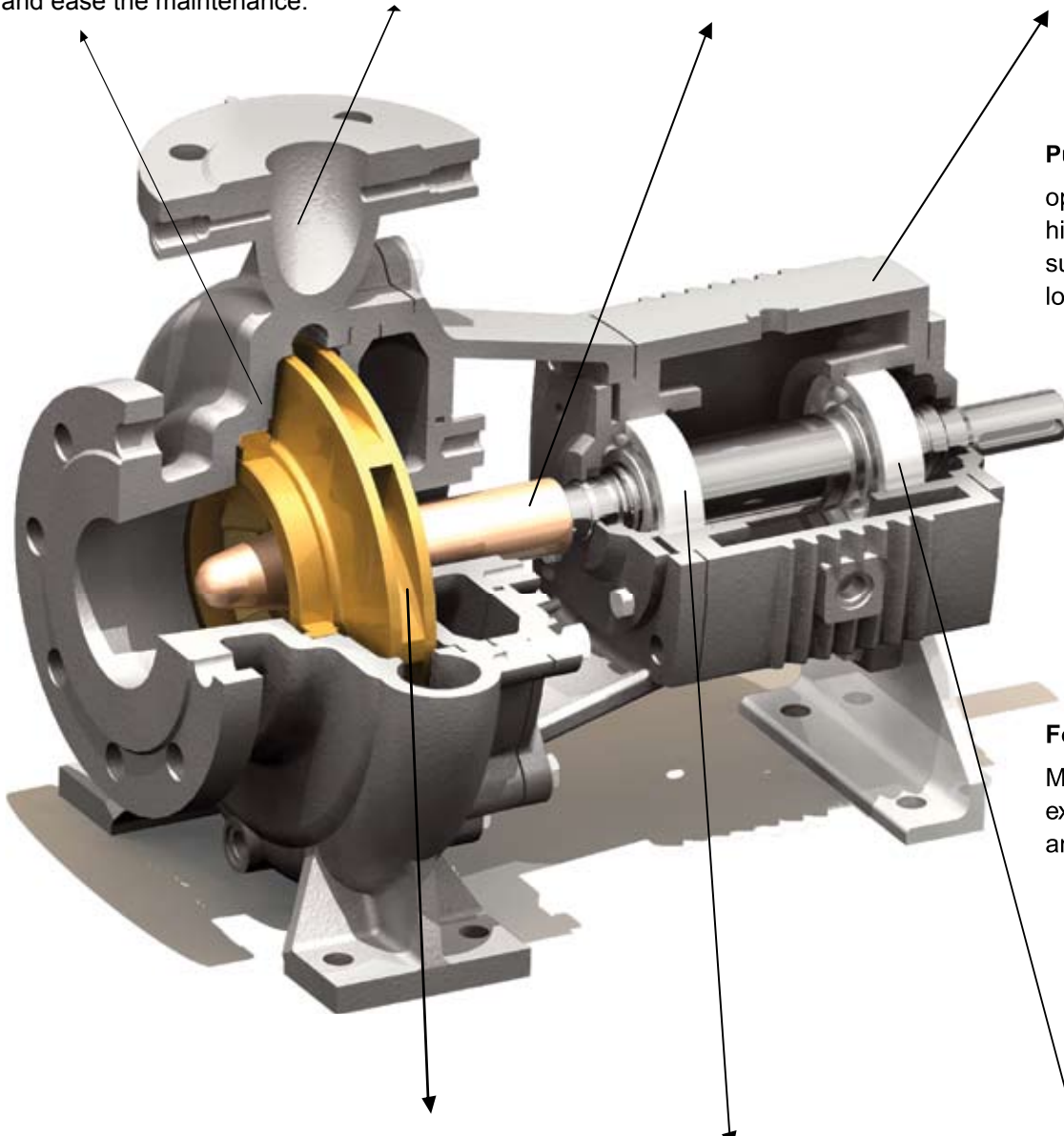

Pump performance

optimized volute design
high efficiency, smooth surfaces, minimal internal losses

Foot

Machined foot assure exact positioning on baseplate and in pipework

Impeller Back vanes

for hydraulic balancing, extending bearing life, keeps solid parts away from shaft sealing area

Impeller

Fully enclosed, single-piece casting gives reliability, long trouble-free operation and high efficiency.

Shaft

The shaft is protected by a replaceable shaft sleeve in stainless steel.

Bearings

Ample dimensioned single and double row ball bearings improve the stiffness and minimize shaft deflection.

TECHNICAL DATA - BEARINGS

■ Bearing bracket size

There are different bearing bracket size according to different size of the pump

Outlet nozzle [mm]	Nominal impeller diameter							
	125	160	200	250	315	400	500	650
32	BB1	BB1	BB1	BB2				
40		BB1	BB1	BB2	BB2			
50		BB1	BB1	BB2	BB2			
65		BB2	BB2	BB2	BB3			
80		BB2	BB2	BB2	BB3	BB3		
100			BB2	BB3	BB3	BB3		
125				BB3	BB3	BB3		
150				BB3	BB4	BB4	BB4	BB6
200				BB4	BB4	BB4	BB4	
250					BB4	BB5	BB5	BB7
300						BB6	BB6	BB7
350						BB6	BB6	BB8

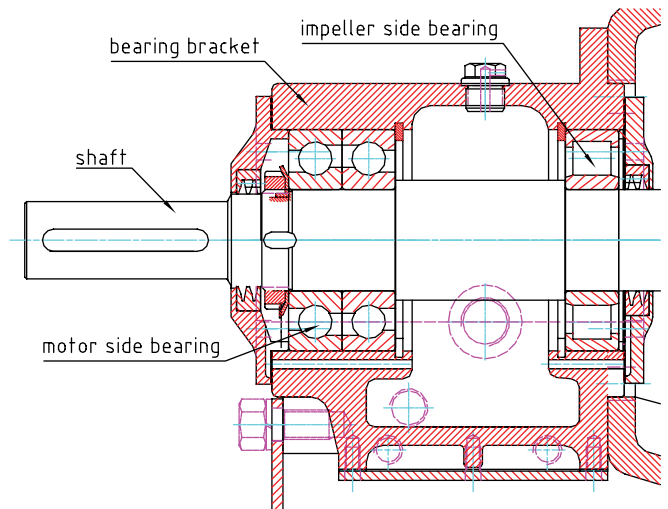

- The bearing assembly includes three bearings oil lubricated, improve the stiffness and minimize shaft deflection
- All the pumps are covered by several sizes of shaft, shaft seal and bearings
- Due to the ample sizes of the bearings and shafts, pumps can have several types of bearing bracket
- Shaft is carried by, on impeller side cylindrical roller bearing and on a two ball bearing, oil lubricated. Bearing covers on both sides with ring seals.

Motor side bearings

Outlet nozzle [mm]	Nominal impeller diameter							
	125	160	200	250	315	400	500	650
32	2 x 7307	2 x 7307	2 x 7307	2 x 7307	-	-	-	-
40		2 x 7307	2 x 7307	2 x 7307	2 x 7307	-	-	-
50		2 x 7307	2 x 7307	2 x 7307	2 x 7307			
65		2 x 7307	2 x 7307	2 x 7307	2 x 7311			
80		2 x 7307	2 x 7307	2 x 7307	2 x 7311	2 x 7311		
100			2 x 7307	2 x 7311	2 x 7311	2 x 7311		
125				2 x 7311	2 x 7311	2 x 7311		
150				2 x 7311	2 x 7313	2 x 7313	2 x 7313	2 x 7319
200				2 x 7313	2 x 7313	2 x 7313	2 x 7313	
250					2 x 7313	2 x 7315	2 x 7315	2 x 7324
300						2 x 7319	2 x 7319	2 x 7324
350						2 x 7319	2 x 7319	2 x 7324

Impeller side bearings

Outlet nozzle [mm]	Nominal impeller diameter							
	125	160	200	250	315	400	500	650
32	NU307	NU 307	NU 307	NU 307	-	-	-	-
40	-	NU 307	NU 307	NU 307	NU 307			
50	-	NU 307	NU 307	NU 307	NU 307			
65	-	NU 307	NU 307	NU 307	NU 311			
80	-	NU 307	NU 307	NU 307	NU307	NU307		
100			NU307	NU307	NU307	NU307		
125				NU307	NU307	NU307		
150				NU307	NU313	NU313	NU313	NU416
200				NU313	NU313	NU313	NU313	
250					NU313	NU413	NU413	NU324
300						NU416	NU416	NU324
350						NU416	NU416	NU324

TECHNICAL DATA - FLANGE CONNECTIONS

Flange connection

- Suction connections flanges DIN EN 1092 PN 10
- Discharge connections flanges DIN EN 1092 PN 16

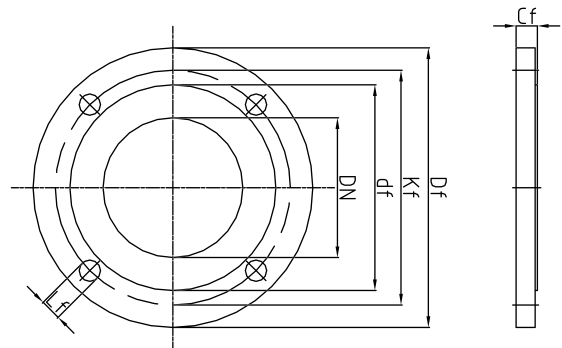

Pump type	Suction connections flanges DIN EN 1092 PN 10					
	DN	Cf	df	Kf	Df	Lf
32-125	50	19	99	125	165	4xØ19
32-160						
32-200						
32-250	65	19	118	145	185	4xØ19
40-160						
40-200						
40-250						
40-315	80	19	132	160	200	8xØ19
50-160						
50-200						
50-250						
50-315						
65-160	100	19	156	180	220	8xØ19
65-200						
65-250						
65-315						
80-160	125	19	184	210	250	8xØ19
80-200						
80-250						
80-315						
80-400						
100-200	125	19	184	210	250	8xØ19
100-250						
100-315						
100-400						
125-250	150	19	211	240	285	8xØ23
125-315						
125-400						
150-250	200	20	266	295	340	8xØ23
150-315						
150-400						
150-500						
150-650						
200-250	200	20	266	295	340	8xØ23
200-315						
200-400						
200-500	250	26	320	350	395	12xØ23
250-315						
250-400	300	28	370	400	445	12xØ23
250-500						
250-650						
300-400						
300-500						
300-650	350	30	430	460	505	16xØ23
350-400						
350-500						
350-650	400	32	482	515	565	16xØ27
350-500						

Pump type	Discharge connections flanges DIN EN 1092 PN 16					
	DN	Cf	df	Kf	Df	Lf
32-125	32	18	76	100	140	4xØ19
32-160						
32-200						
32-250	40	19	84	110	150	4xØ19
40-160						
40-200						
40-250						
40-315	50	19	99	125	165	4xØ19
50-160						
50-200						
50-250						
50-315						
65-160	65	19	118	145	185	4xØ19
65-200						
65-250						
65-315						
80-160	80	19	132	160	200	8xØ19
80-200						
80-250						
80-315						
80-400						
100-200	100	19	156	180	220	8xØ19
100-250						
100-315						
100-400						
125-250	125	19	184	210	250	8xØ19
125-315						
125-400						
150-250	150	19	211	240	285	8xØ23
150-315						
150-400						
150-500						
150-650						
200-250	200	20	266	295	340	12xØ23
200-315						
200-400						
200-500	250	26	320	355	405	12xØ27
250-315						
250-400	250	26	320	355	405	12xØ27
250-500						
250-650						
300-400						
300-500						
300-650	300	32	378	410	460	12xØ27
350-400						
350-500						
350-650	350	36	438	470	520	16xØ27
350-500						

TECHNICAL DATA - SHAFT SEALING

■ Shaft Sealing

The shaft sealing could be arranged by soft packing or mechanical seal. Conversion from the gland packing to the mechanical seal is possible without any rework on the casing cover by using the relevant replacement parts.

In soft packing arrangements the shaft is protected by replaceable, stainless sleeve while the stuffing box is furnished with lantern ring for introduction of cooling liquid into the packing.

On special demand the pumps could be furnished with mechanical seal in accordance with the characteristics of the liquid and the operating conditions. Single mech. seal are according EN 12756 (DIN 24960)

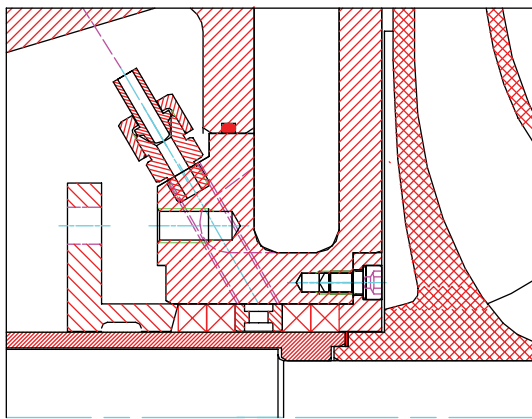

- Cooled stuffing box with internal barrier fluid for pumping of clean liquids in suction operation

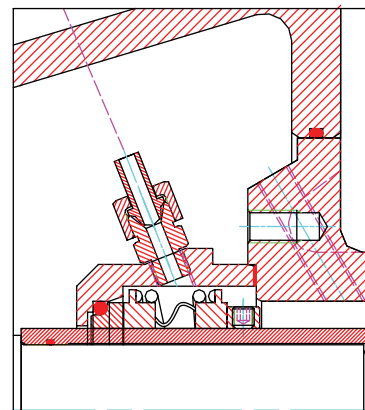

- Single acting mechanical seal with cooling of seal surface, unbalanced Heavy Duty Rubber Bellows, Single Acting Seal with Standard Seat.

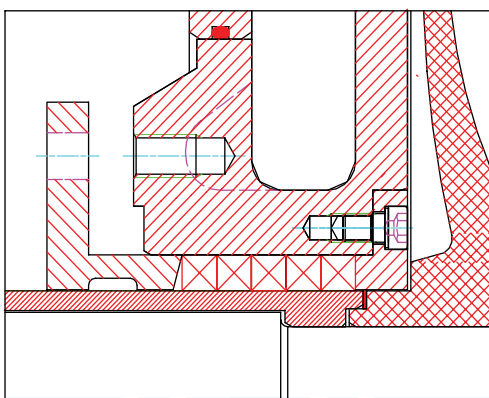

- Uncooled stuffing box without internal barrier fluid for pumping of clean liquids in suction operation

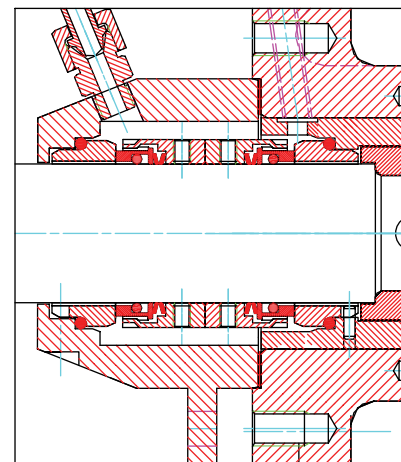

- Double –acting mechanical seal (back to back) both sides unbalanced

TECHNICAL DATA - INSTALLATION DIMENSIONS

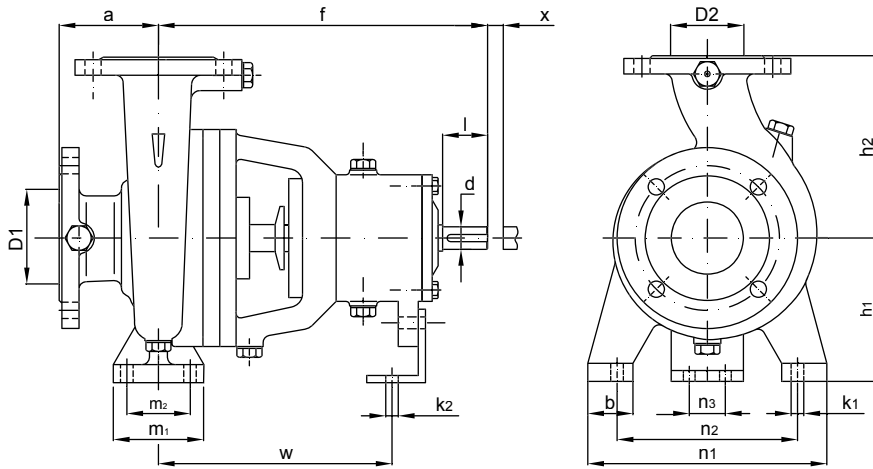

SIZE	Dimensions (mm)																	
	D1	D2	a	f	h1	h2	b	m1	m2	n1	n2	n3	w	x	d	l	k1	k2
32-125	50	32	80	385	112	140	50	100	70	190	140	110	285	100	24	50	M12	M12
32-160	50	32	80	385	132	160	50	100	70	240	190	140	285	100	24	50	M12	M12
32-200	50	32	80	385	160	180	50	100	70	240	190	140	285	100	24	50	M12	M12
32-250	50	32	100	500	180	225	65	125	95	320	250	190	370	100	32	80	M12	M12
40-160	65	40	80	385	132	160	50	100	70	240	190	140	285	100	24	50	M12	M12
40-200	65	40	100	385	160	180	50	100	70	265	212	165	285	100	24	50	M12	M12
40-250	65	40	100	500	180	225	65	125	95	320	250	190	370	100	32	80	M12	M12
40-315	65	40	125	500	200	250	65	125	95	345	280	215	370	100	32	80	M12	M12
50-160	80	50	100	385	160	180	50	100	70	265	212	165	285	100	24	50	M12	M12
50-200	80	50	100	385	160	200	50	100	70	265	212	165	285	100	24	50	M12	M12
50-250	80	50	125	500	180	225	65	125	95	320	250	190	370	100	32	80	M12	M12
50-315	80	50	125	500	225	280	65	125	95	345	280	215	370	100	32	80	M12	M12
65-125	80	65	100	385	132	160	50	100	70	240	190	110	285	100	24	50	M12	M12
65-160	100	65	100	500	160	200	65	125	95	280	212	150	370	100	32	80	M12	M12
65-200	100	65	100	500	180	225	65	125	95	320	250	190	370	140	32	80	M12	M12
65-250	100	65	125	500	200	250	80	160	120	360	280	200	370	140	32	80	M16	M12
65-315	100	65	125	530	225	280	80	160	120	400	315	240	370	140	42	110	M16	M12
80-125	100	80	100	385	160	180	65	125	95	280	212	110	285	140	24	50	M12	M12
80-160	125	80	125	500	180	225	65	125	95	320	250	190	370	140	32	80	M12	M12
80-200	125	80	125	500	180	250	65	125	95	345	280	215	370	140	32	80	M16	M12
80-250	125	80	125	500	225	280	80	160	120	400	315	240	370	140	32	80	M16	M12
80-315	125	80	125	530	250	315	80	160	120	400	315	240	370	140	42	110	M16	M12
80-400	125	80	125	530	280	355	80	160	120	435	355	275	370	140	42	110	M16	M12
100-200	125	100	125	500	200	280	80	160	120	360	280	200	370	140	32	80	M16	M12
100-250	125	100	140	530	225	280	80	160	120	400	315	240	370	140	42	110	M16	M12
100-315	125	100	140	530	250	315	80	160	120	400	315	240	370	140	42	110	M16	M12
100-400	125	100	140	530	280	355	100	200	150	500	400	300	370	140	42	110	M20	M12
125-250	150	125	140	530	250	355	80	160	120	400	315	240	370	140	42	110	M16	M12
125-315	150	125	140	530	280	355	100	200	150	500	400	300	370	140	42	110	M20	M12
125-400	150	125	140	530	315	400	100	200	150	500	400	300	370	140	42	110	M20	M12
150-250	200	150	160	530	280	375	100	200	150	500	400	300	370	180	42	110	M20	M12
150-315	200	150	160	670	315	400	100	200	150	550	450	350	500	180	48	110	M20	M16
150-400	200	150	160	670	315	450	100	200	150	550	450	350	500	180	48	110	M20	M16
150-500	200	150	180	670	375	500	100	200	150	550	450	350	500	180	48	110	M20	M16
200-250	200	200	180	670	355	425	100	200	150	550	450	350	500	180	48	110	M20	M16
200-315	250	200	200	670	355	450	110	200	150	550	450	350	500	180	48	110	M20	M16
200-400	250	200	180	670	355	500	100	200	150	550	450	350	500	180	48	110	M20	M16
200-500	250	200	200	670	425	560	100	200	150	660	560	460	565	180	60	140	M20	M16
250-315	300	250	250	670	400	560	130	260	190	690	560	430	500	180	48	110	M24	M16
250-400	300	250	200	720	425	600	130	260	190	800	670	540	515	180	60	140	M24	M16
250-500	300	250	200	720	475	670	130	260	190	800	670	540	515	180	60	140	M24	M16
250-650	300	250	300	1090	500	750	225	400	300	1080	1000	630	730	250	95	170	M24	M16
300-400	350	300	300	900	500	630	180	360	250	900	750	540	680	250	75	150	M24	M16
300-500	350	300	300	900	560	750	225	400	300	1080	1000	630	680	250	75	150	M24	M16
300-650	350	300	300	1090	600	800	225	400	300	1250	1170	800	730	250	95	170	M24	M16
350-400	350	350	350	930	600	750	225	400	300	1250	1170	800	710	315	75	150	M24	M16
350-500	350	350	300	900	670	850	225	400	300	1250	1170	800	630	250	75	150	M24	M16
350-650	400	350	300	1150	630	850	225	400	300	1250	1170	800	740	250	110	210	M24	M16

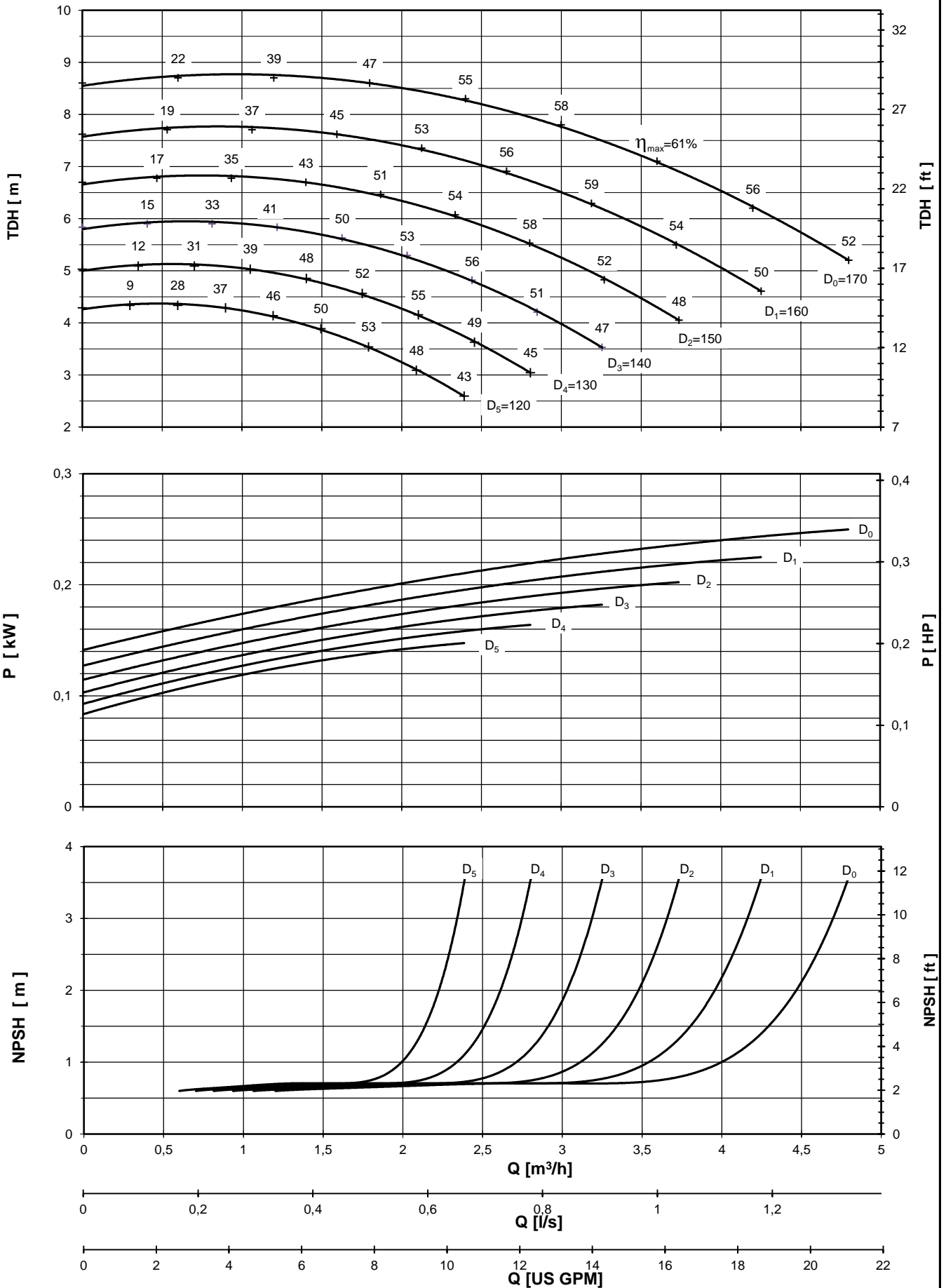

Performance curves are valid for clean cold water-kinematic viscosity 1 [mm²/s], density 1000 [kg/m³]. Methods and tolerances of presented performance curves are in accordance with ISO 9906 - Annex A

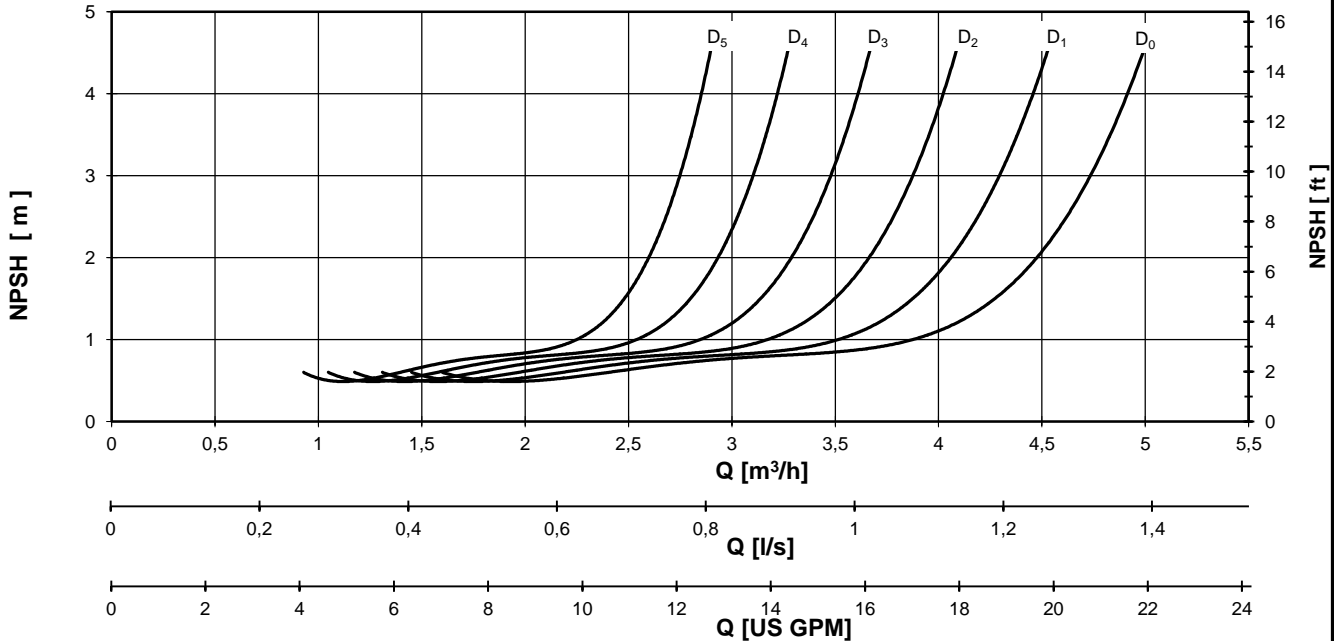
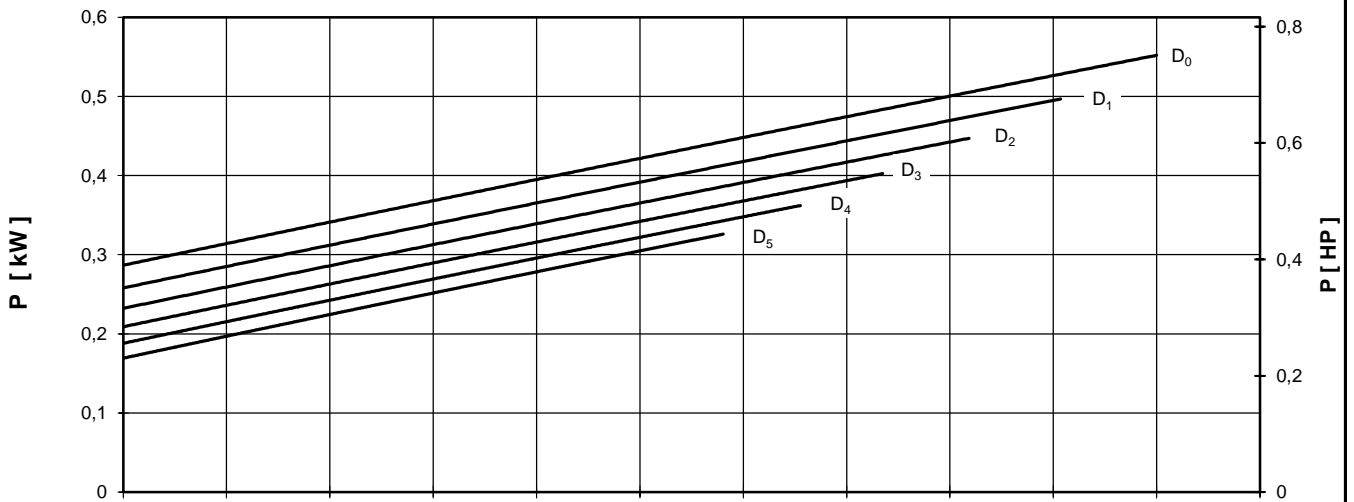
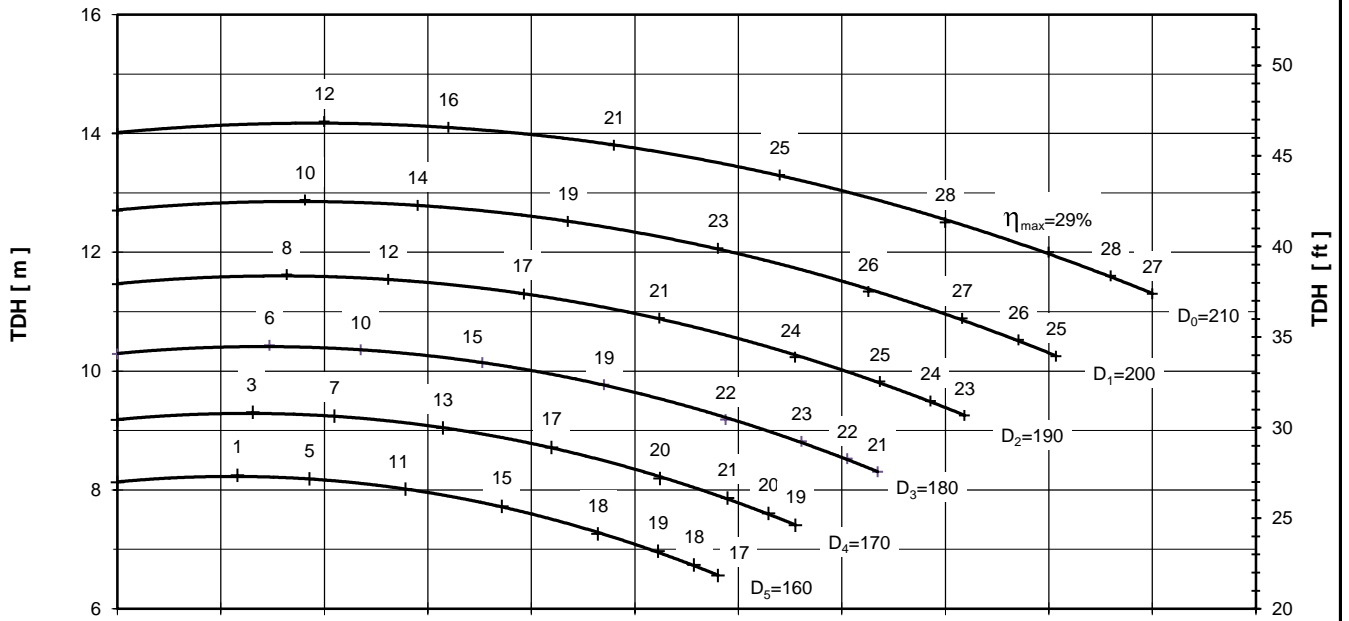

Performance curves are valid for clean cold water-kinematic viscosity $1 [mm^2/s]$, density $1000 [kg/m^3]$. Methods and tolerances of presented performance curves are in accordance with ISO 9906 - Annex A

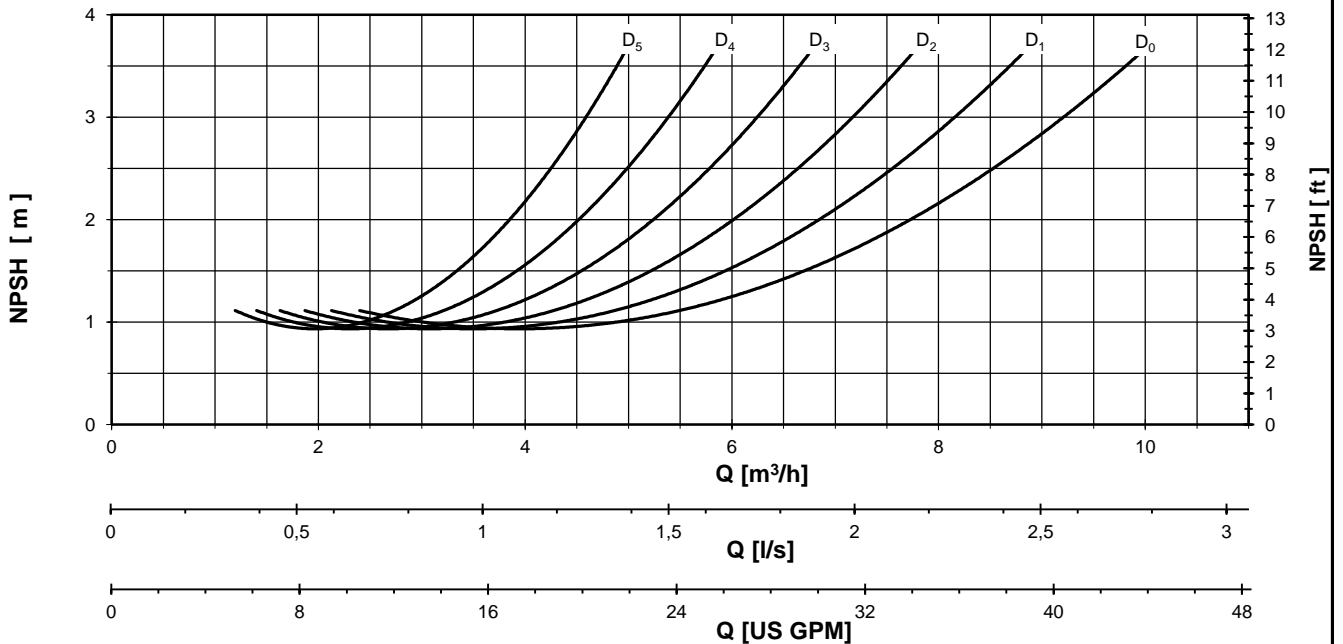
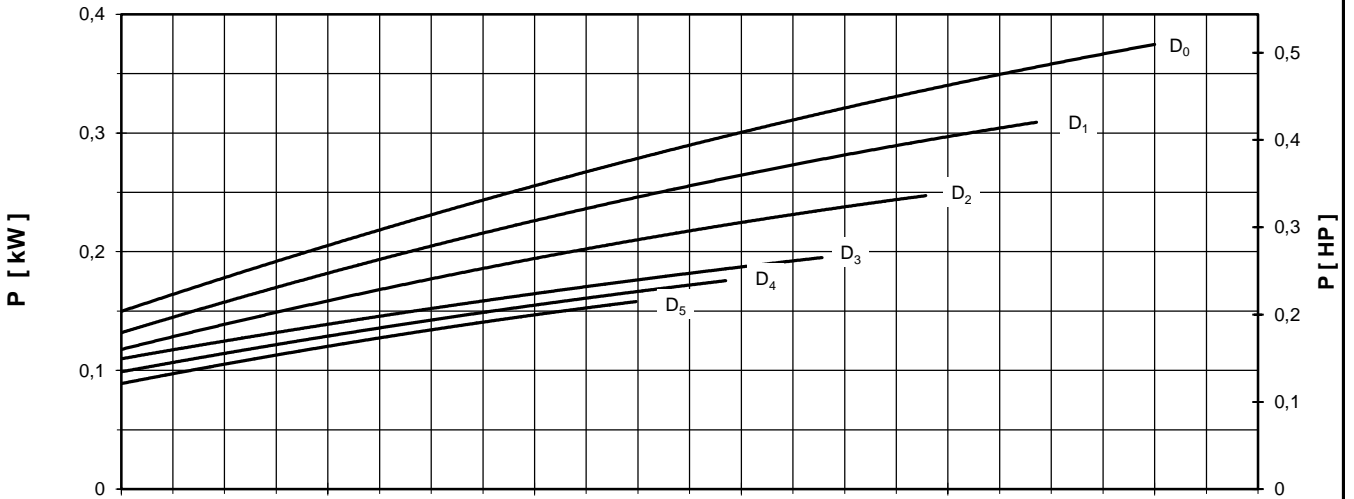
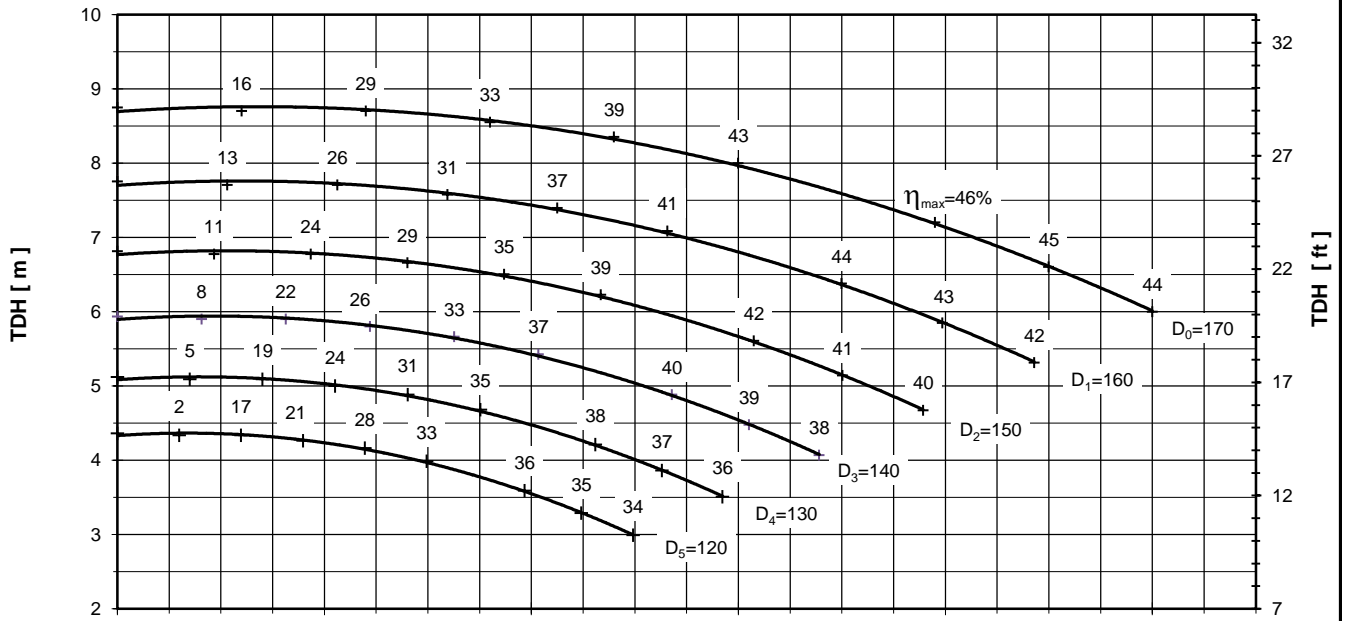

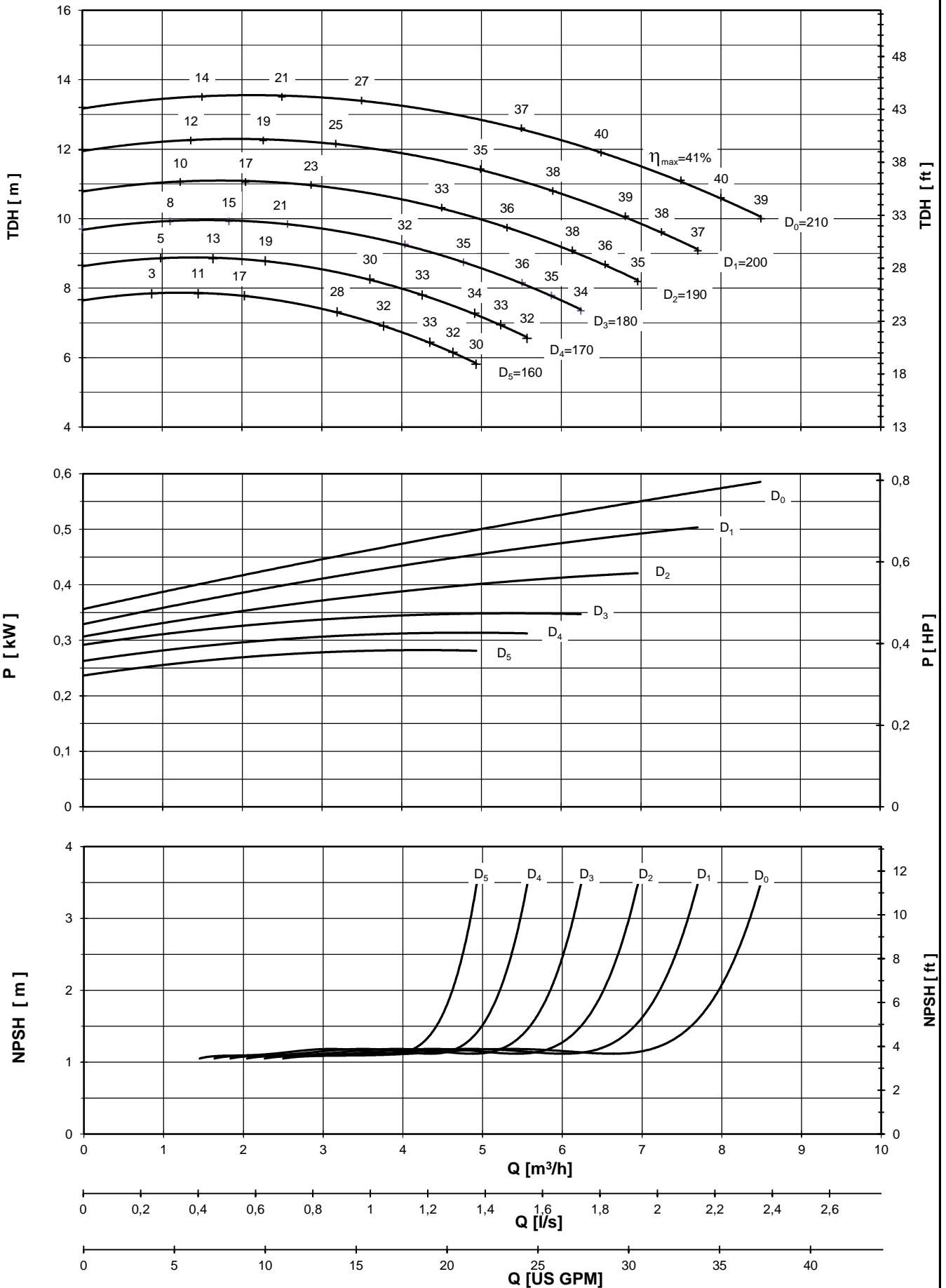

Performance curves are valid for clean cold water-kinematic viscosity 1 [mm²/s], density 1000 [kg/m³]. Methods and tolerances of presented performance curves are in accordance with ISO 9906 - Annex A

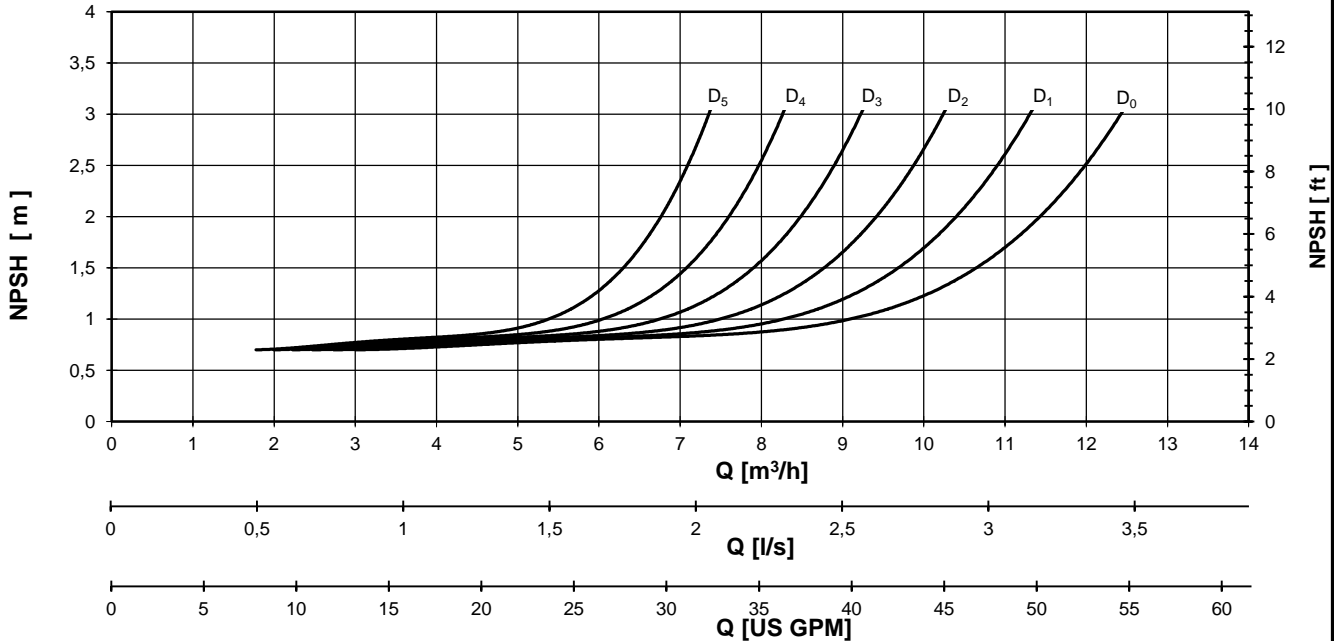
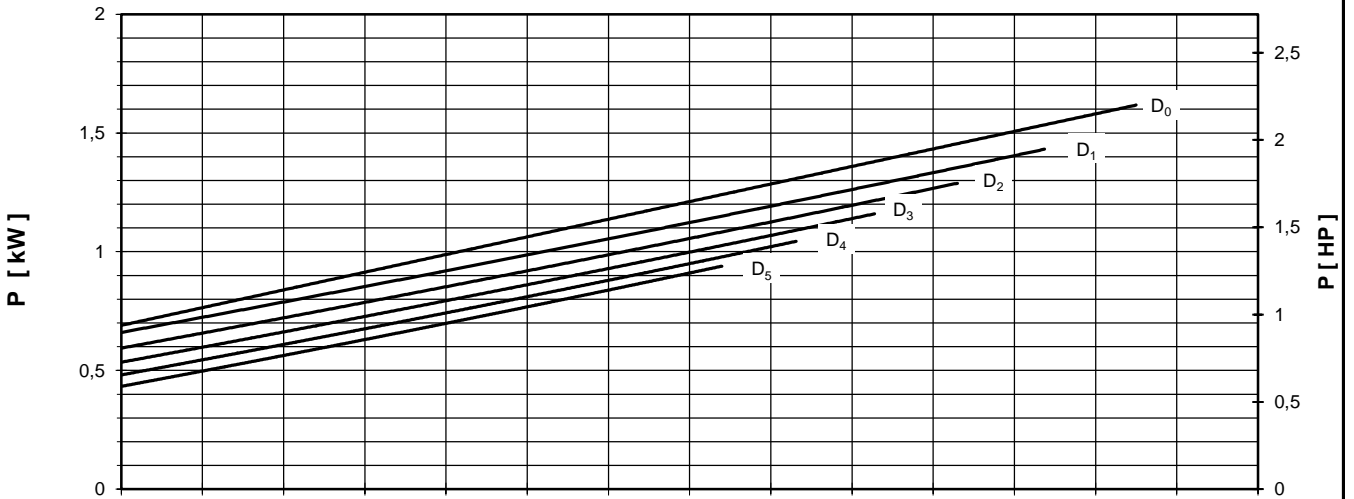
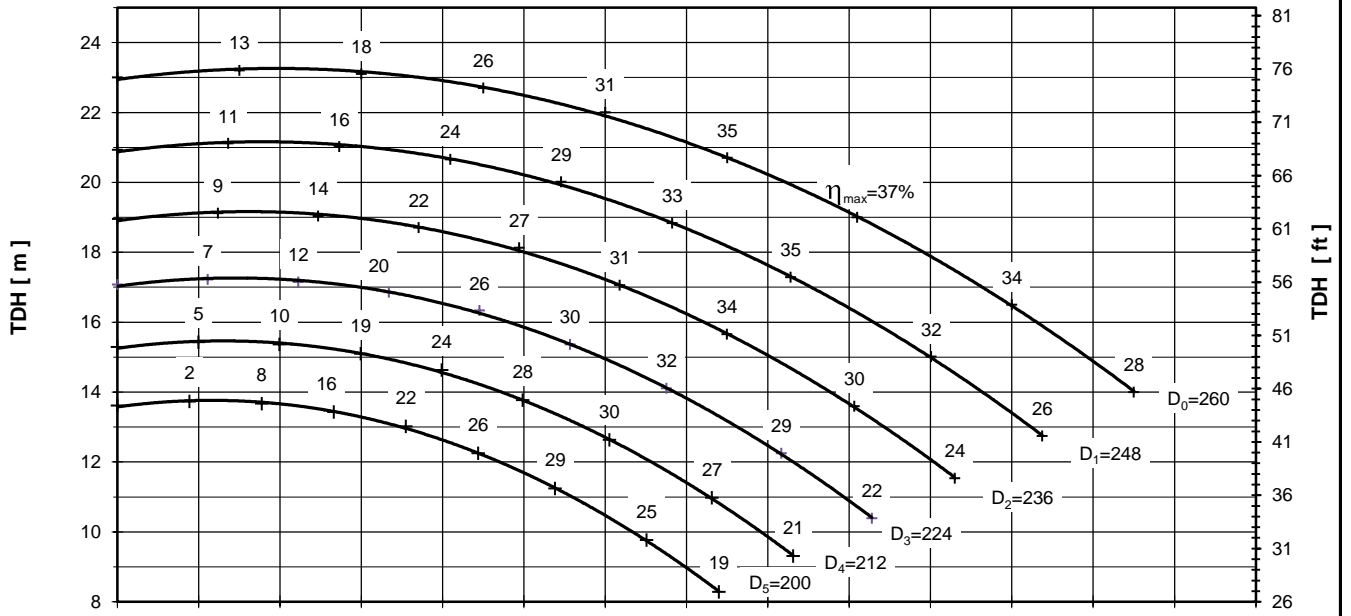

Performance curves are valid for clean cold water-kinematic viscosity 1 [mm²/s], density 1000 [kg/m³]. Methods and tolerances of presented performance curves are in accordance with ISO 9906 - Annex A

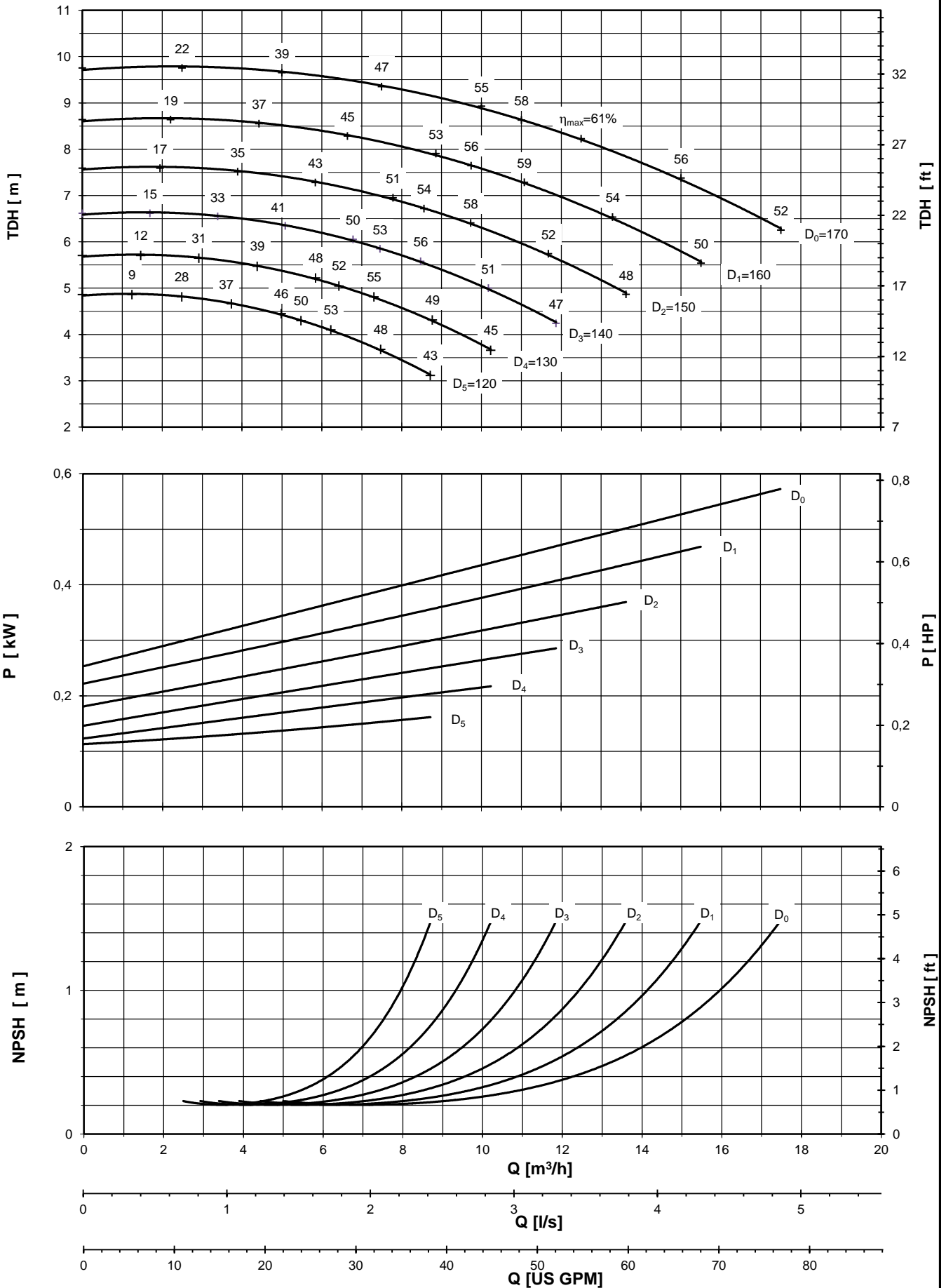

Performance curves are valid for clean cold water-kinematic viscosity 1 [mm²/s], density 1000 [kg/m³]. Methods and tolerances of presented performance curves are in accordance with ISO 9906 - Annex A

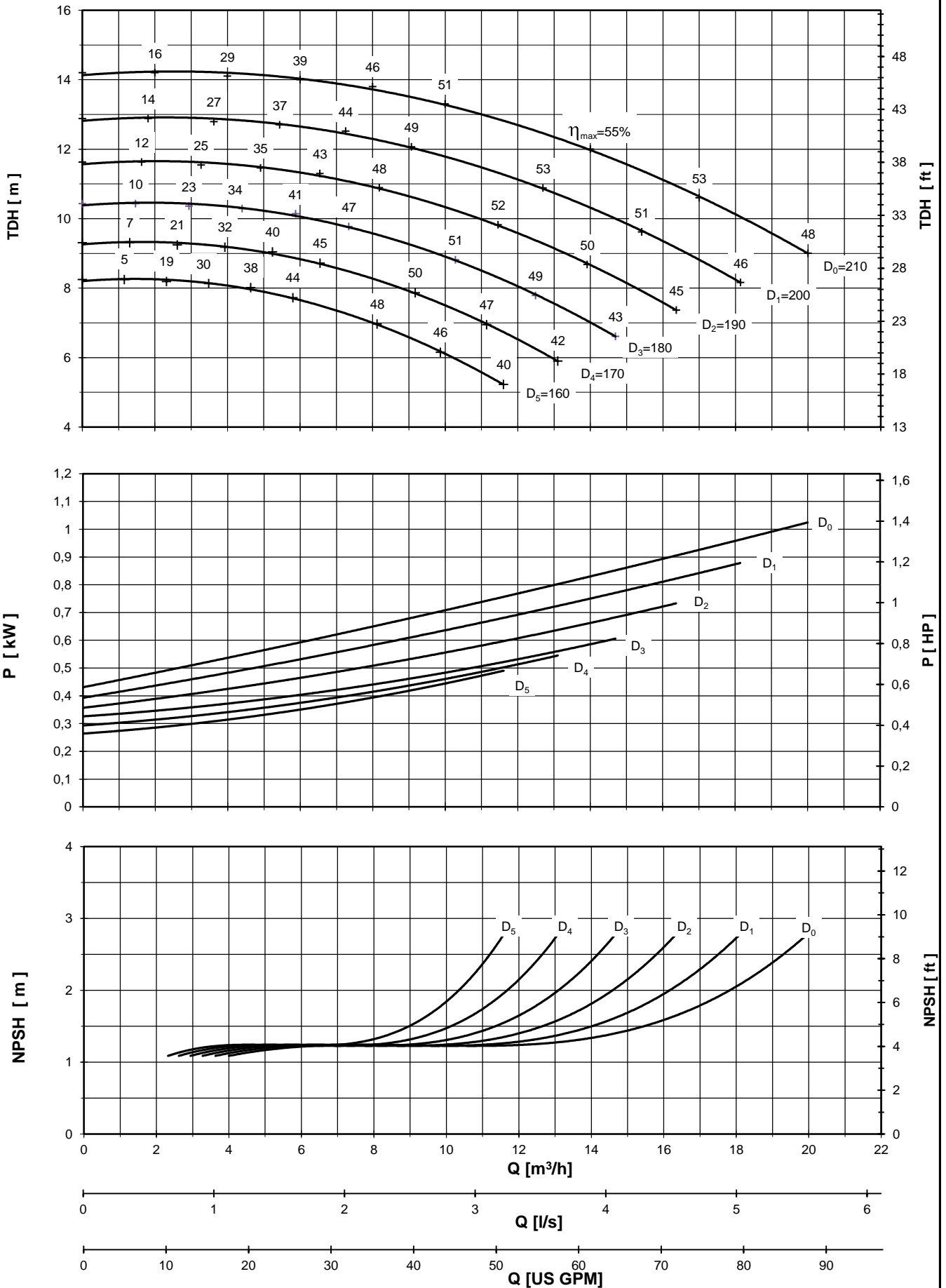

Performance curves are valid for clean cold water-kinematic viscosity 1 [mm²/s], density 1000 [kg/m³]. Methods and tolerances of presented performance curves are in accordance with ISO 9906 - Annex A



PUMP PERFORMANCE CURVES
No. 4HS.0148.03

PUMP TYPE
SCP 40 - 250
1450 [rpm]

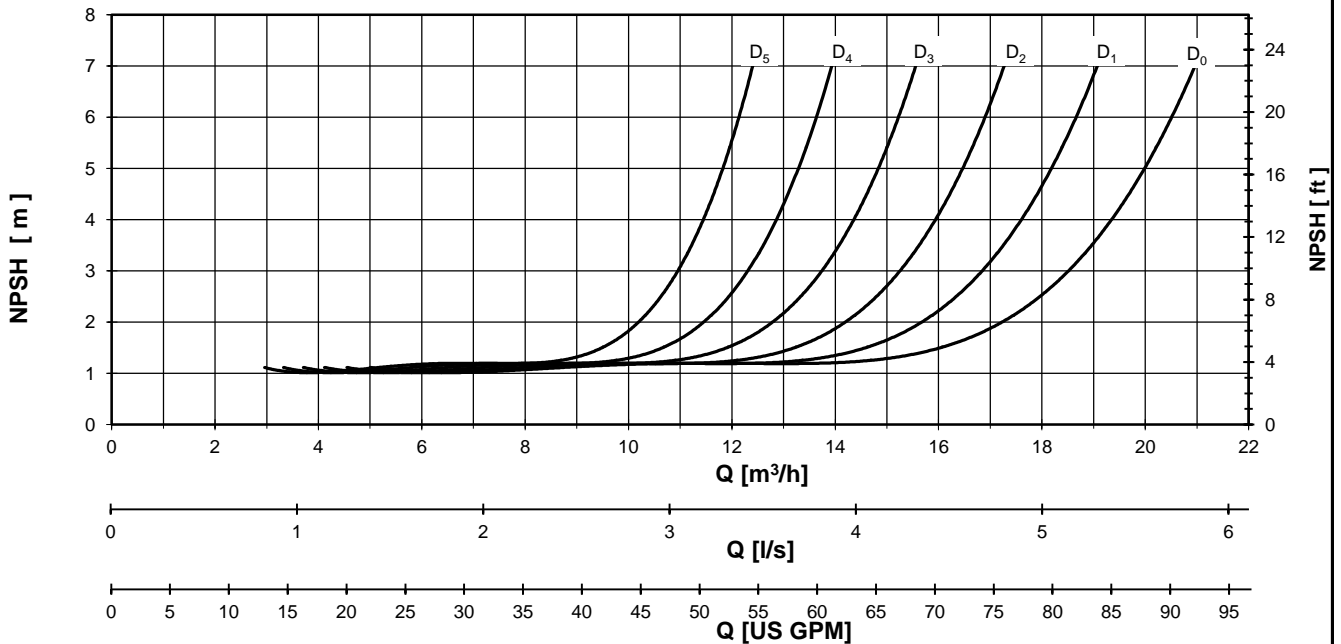
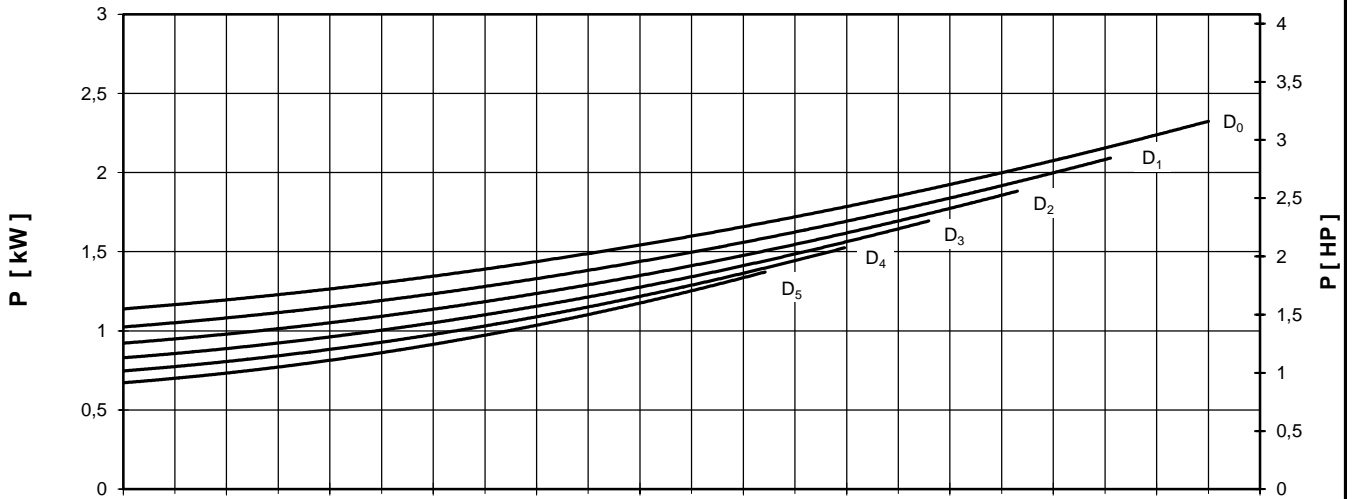
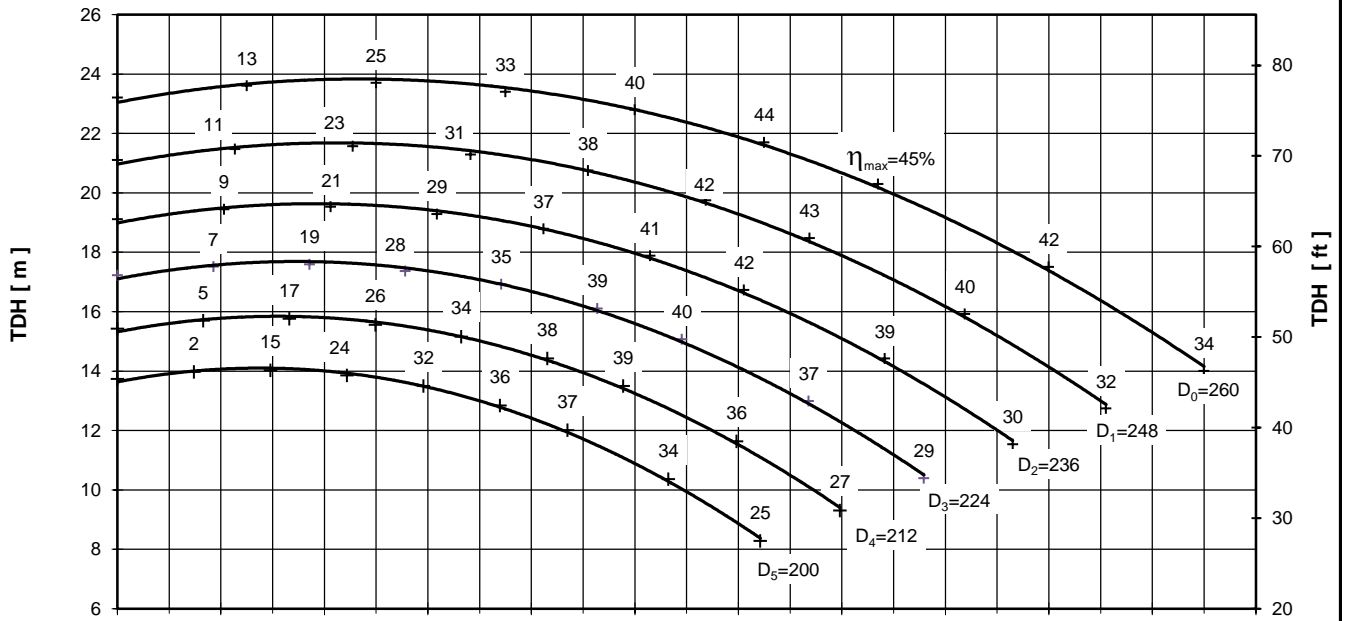

Performance curves are valid for clean cold water-kinematic viscosity 1 [mm²/s], density 1000 [kg/m³]. Methods and tolerances of presented performance curves are in accordance with ISO 9906 - Annex A



PUMP PERFORMANCE CURVES
No. 4HD.0149.03

PUMP TYPE
SCP 40 - 315
1450 [rpm]

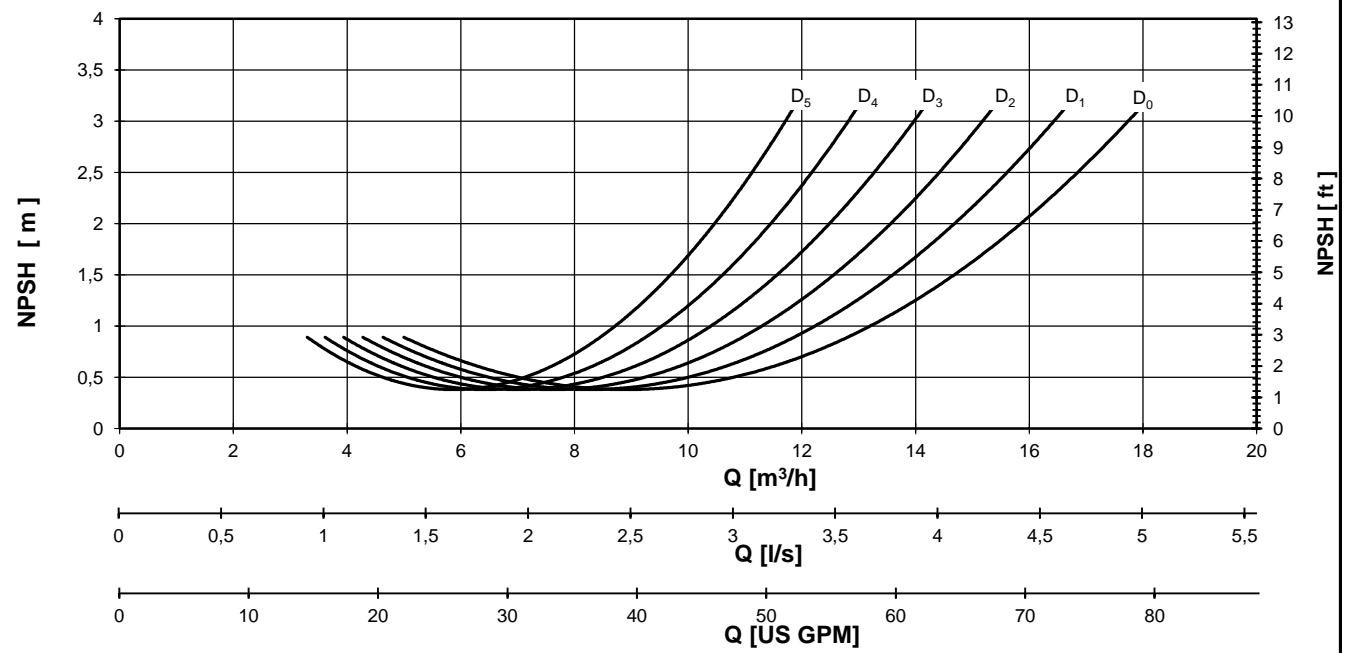
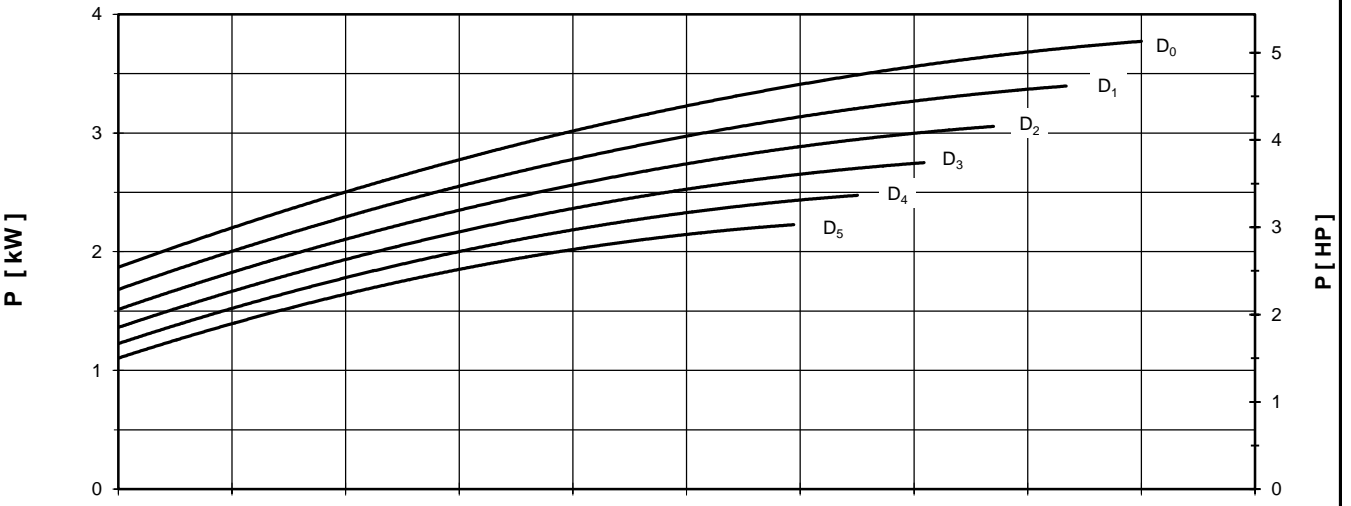
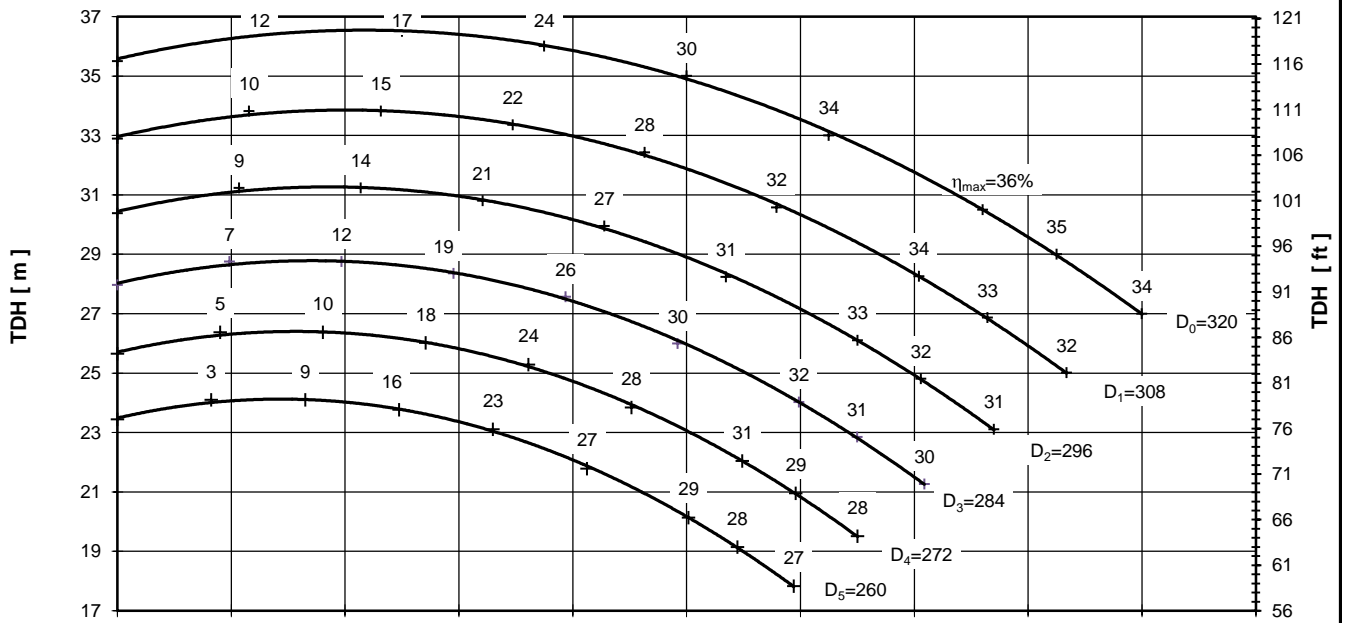

Performance curves are valid for clean cold water-kinematic viscosity 1 [mm²/s], density 1000 [kg/m³]. Methods and tolerances of presented performance curves are in accordance with ISO 9906 - Annex A

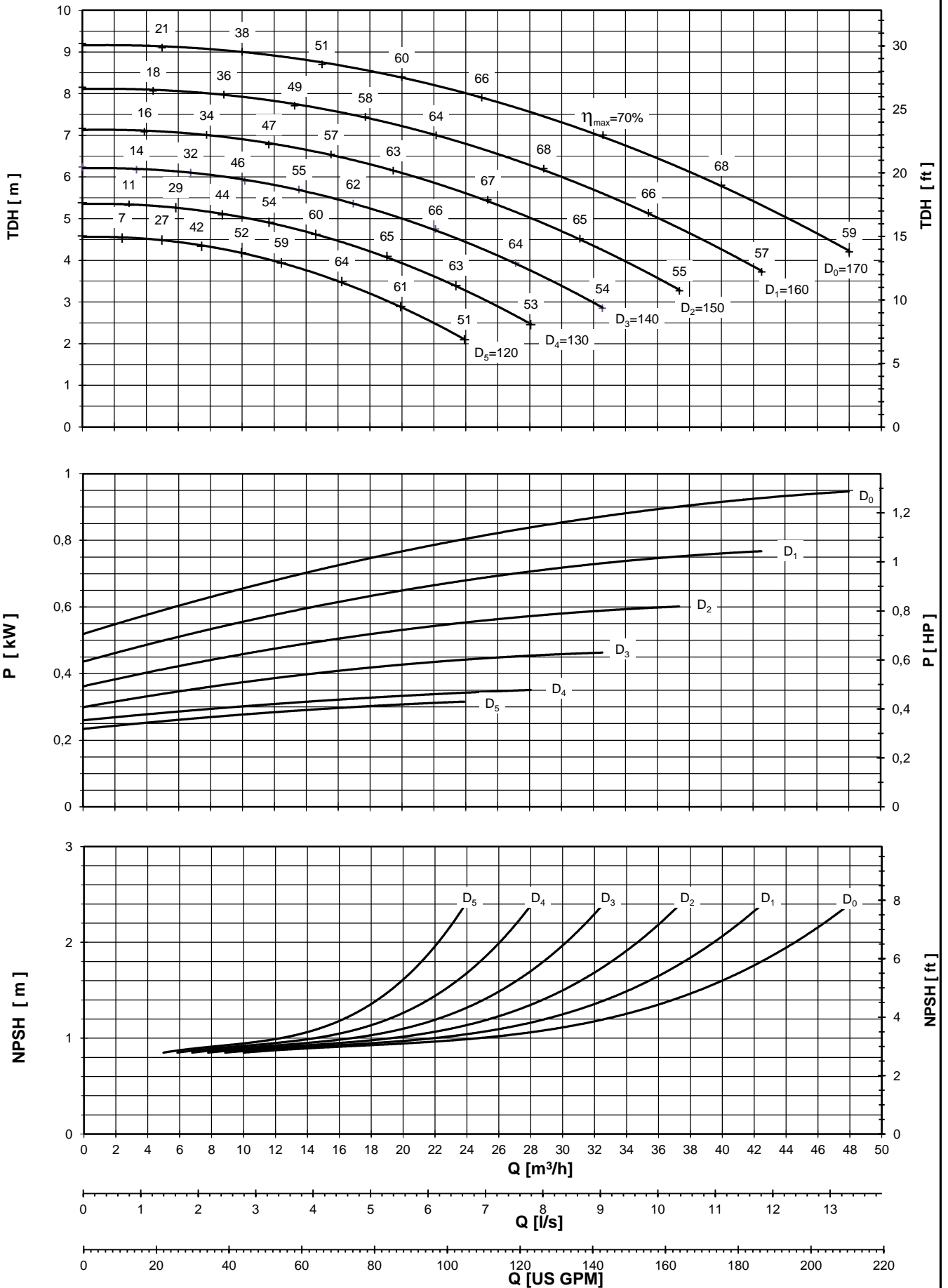

Performance curves are valid for clean cold water-kinematic viscosity 1 [mm²/s], density 1000 [kg/m³]. Methods and tolerances of presented performance curves are in accordance with ISO 9906 - Annex A

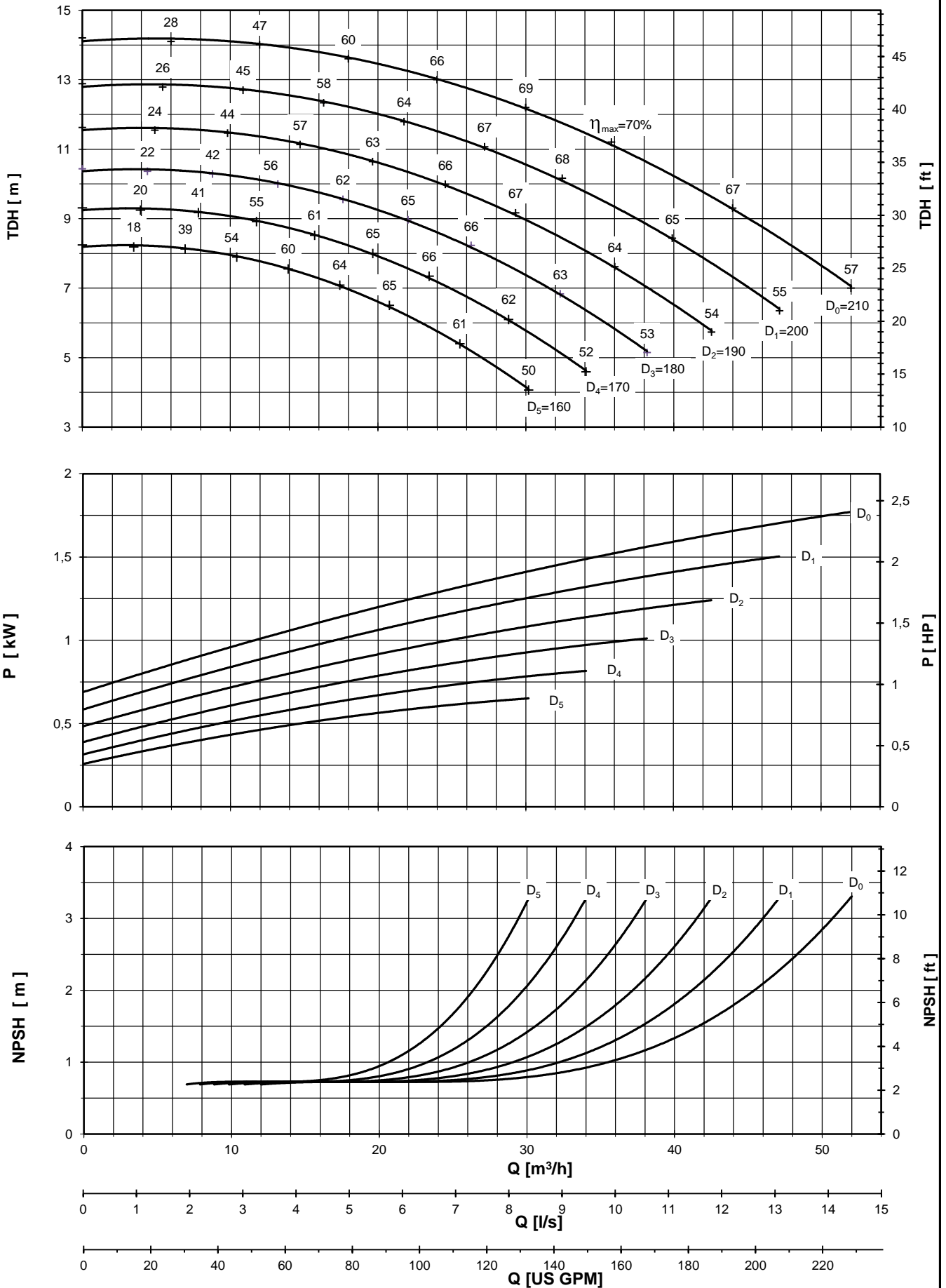

Performance curves are valid for clean cold water-kinematic viscosity 1 [mm²/s], density 1000 [kg/m³]. Methods and tolerances of presented performance curves are in accordance with ISO 9906 - Annex A

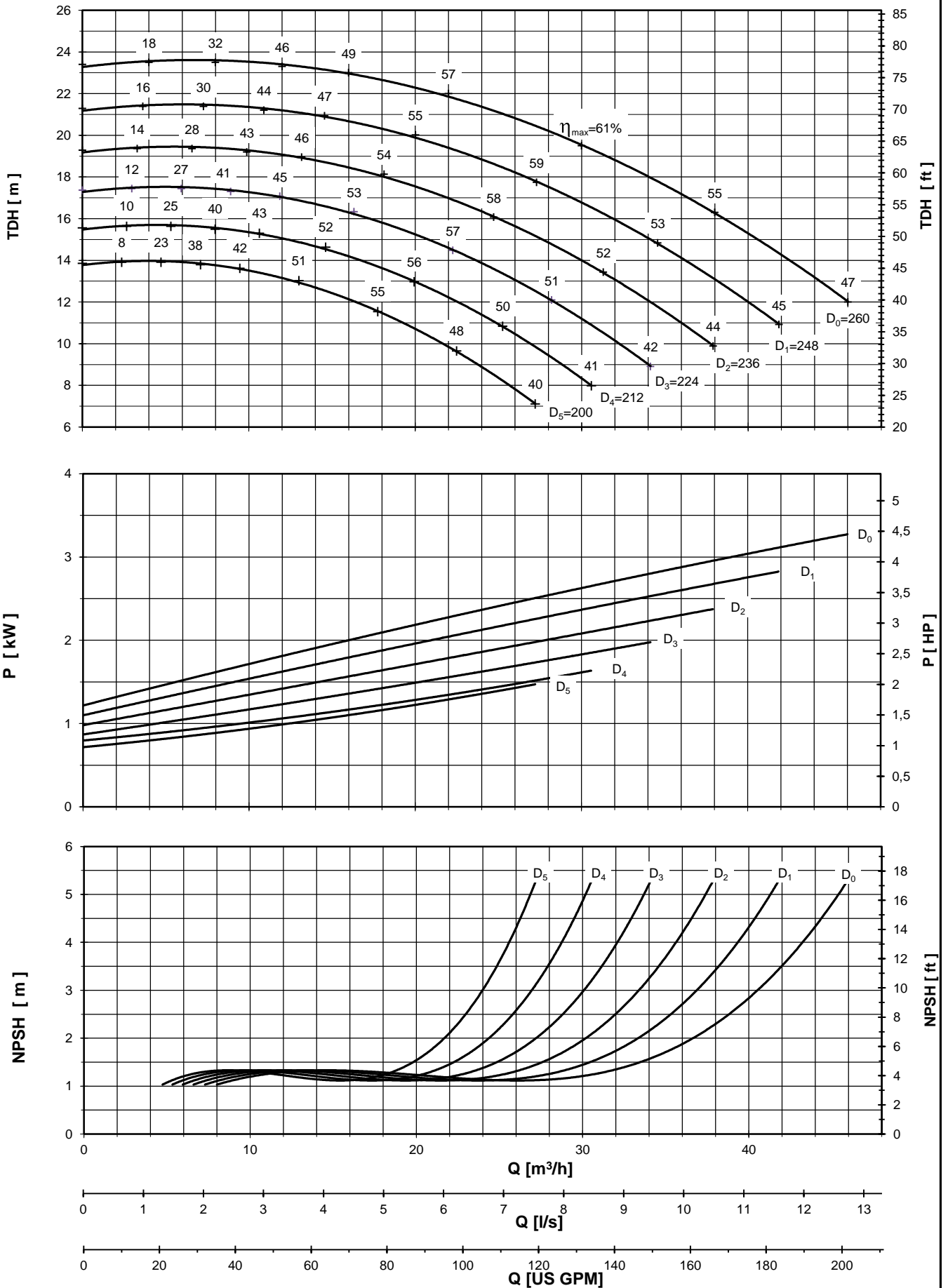

Performance curves are valid for clean cold water-kinematic viscosity 1 [mm²/s], density 1000 [kg/m³]. Methods and tolerances of presented performance curves are in accordance with ISO 9906 - Annex A

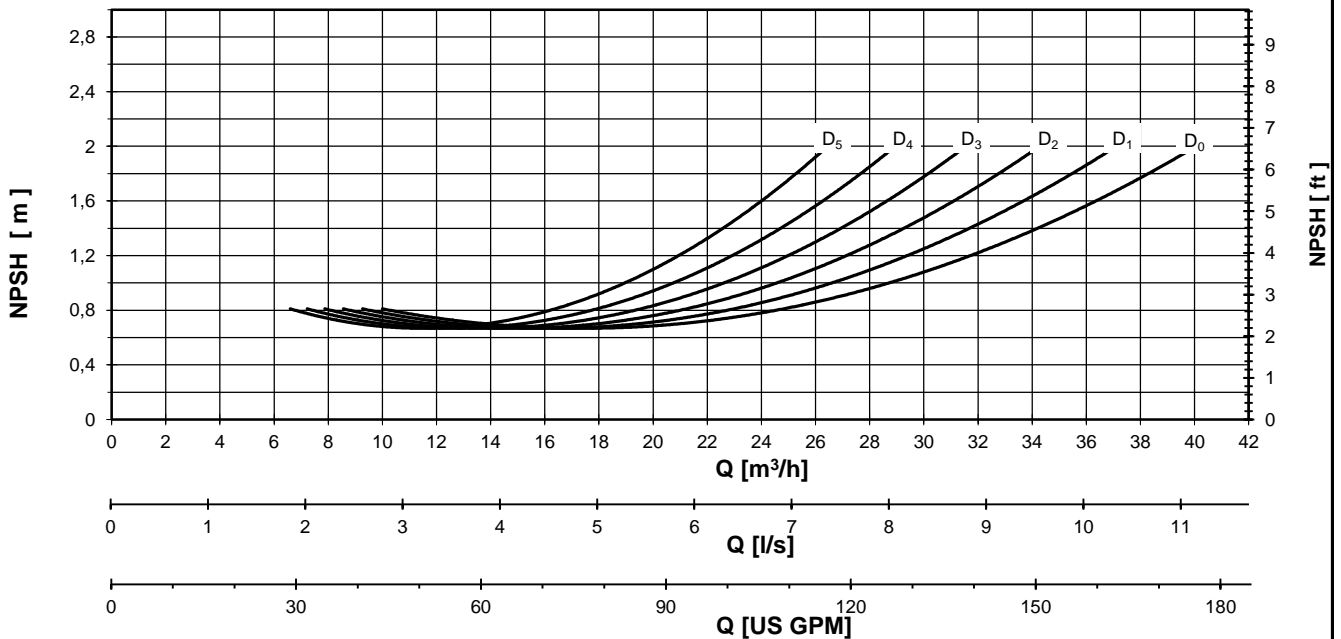
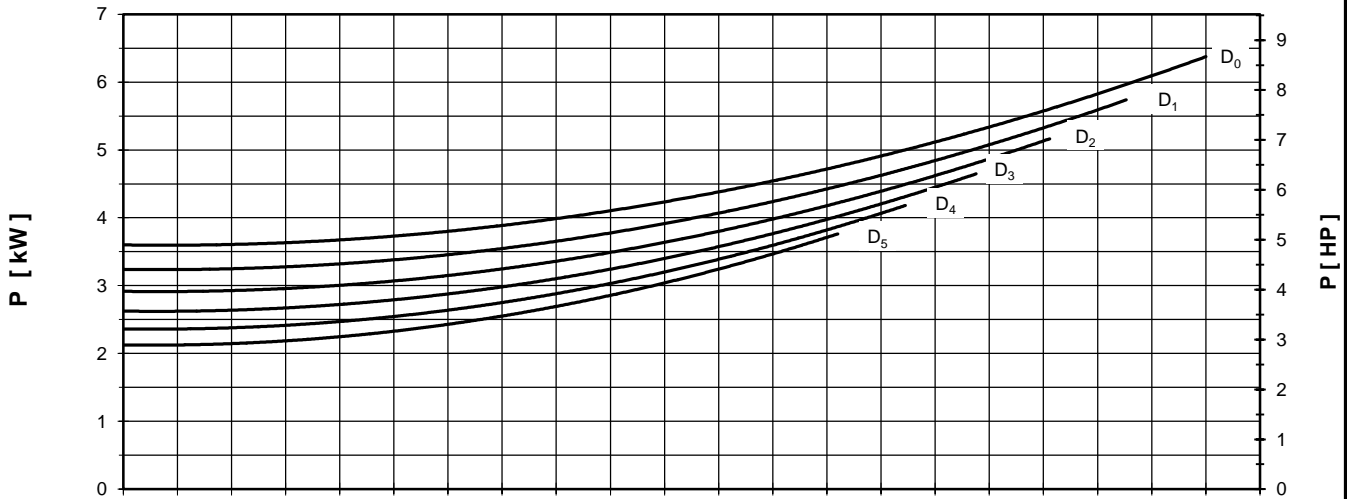
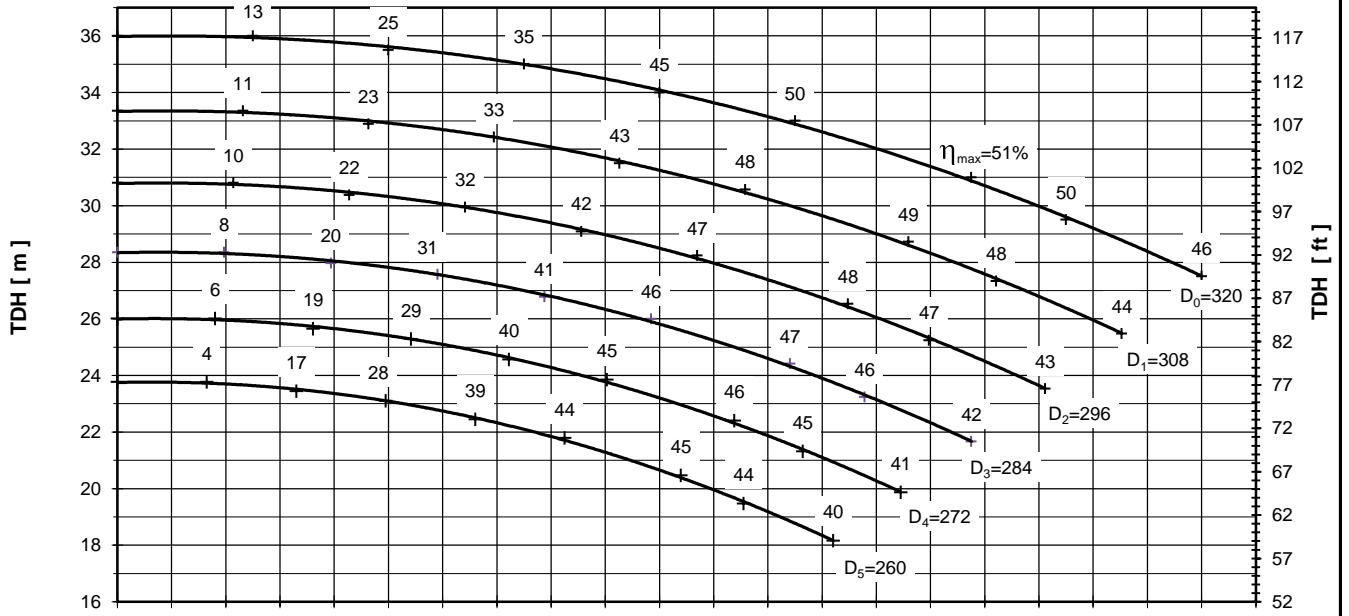

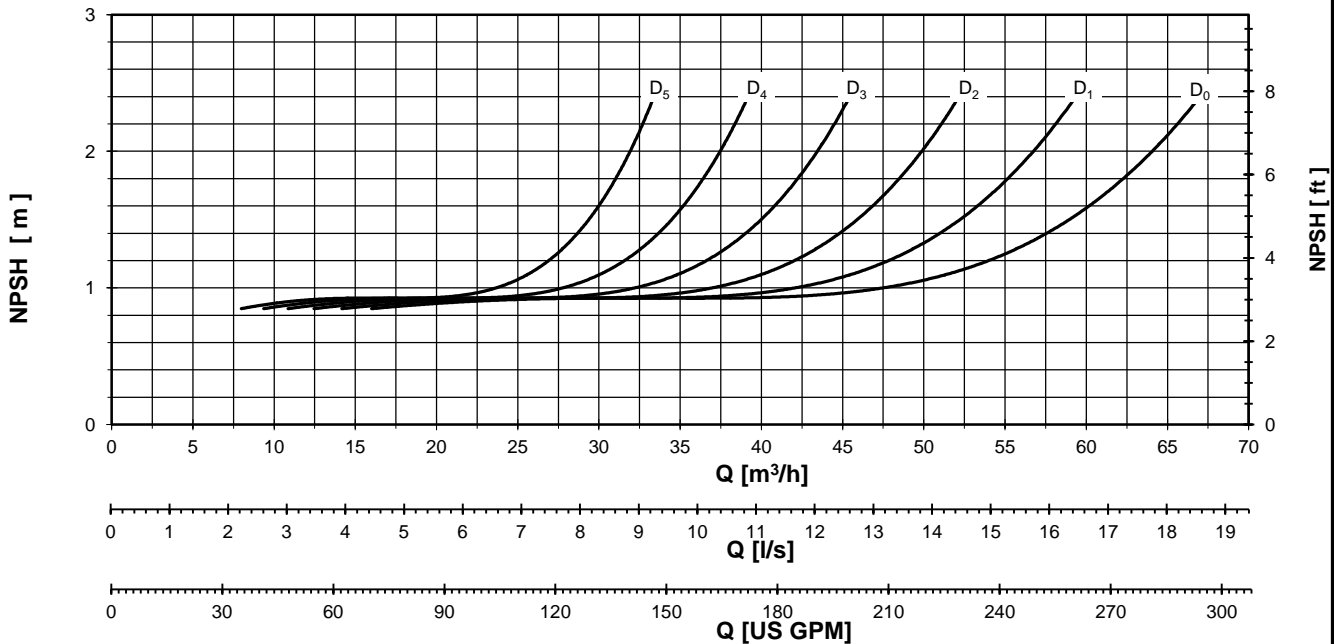
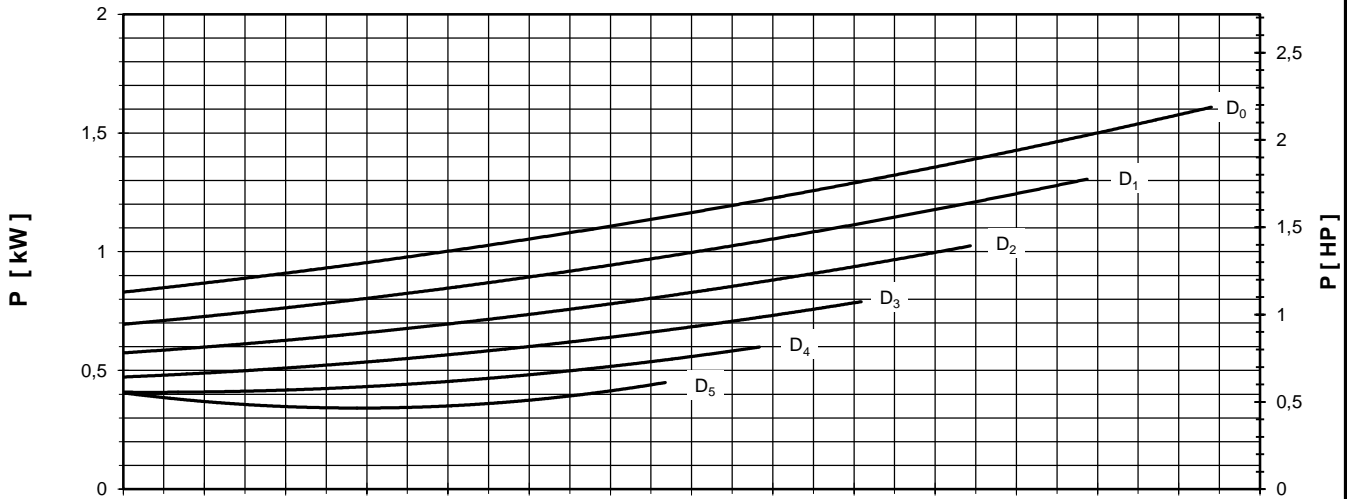
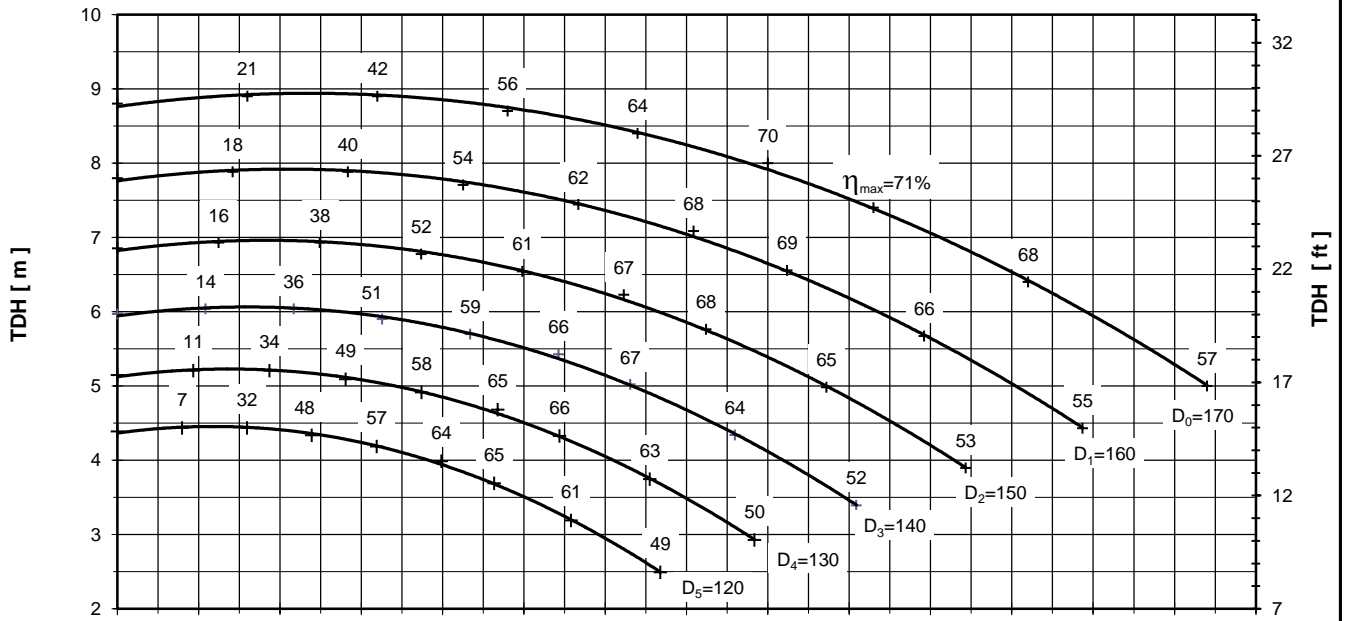

Performance curves are valid for clean cold water-kinematic viscosity 1 [mm²/s], density 1000 [kg/m³]. Methods and tolerances of presented performance curves are in accordance with ISO 9906 - Annex A

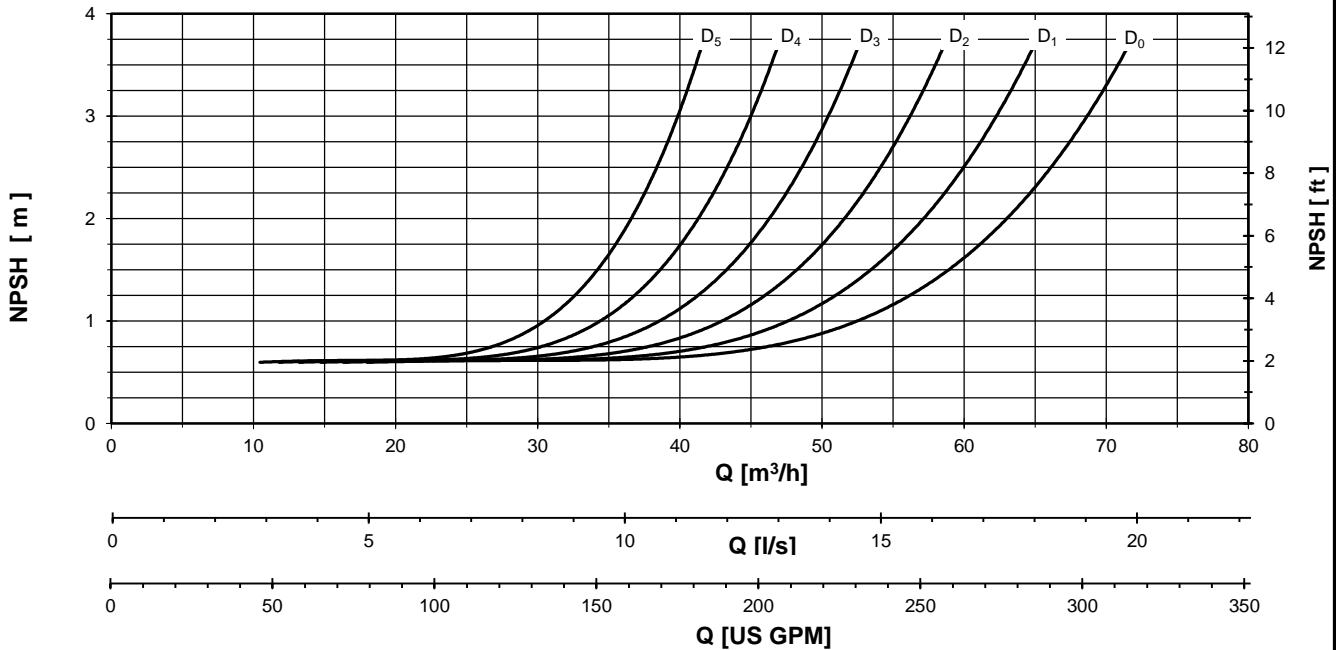
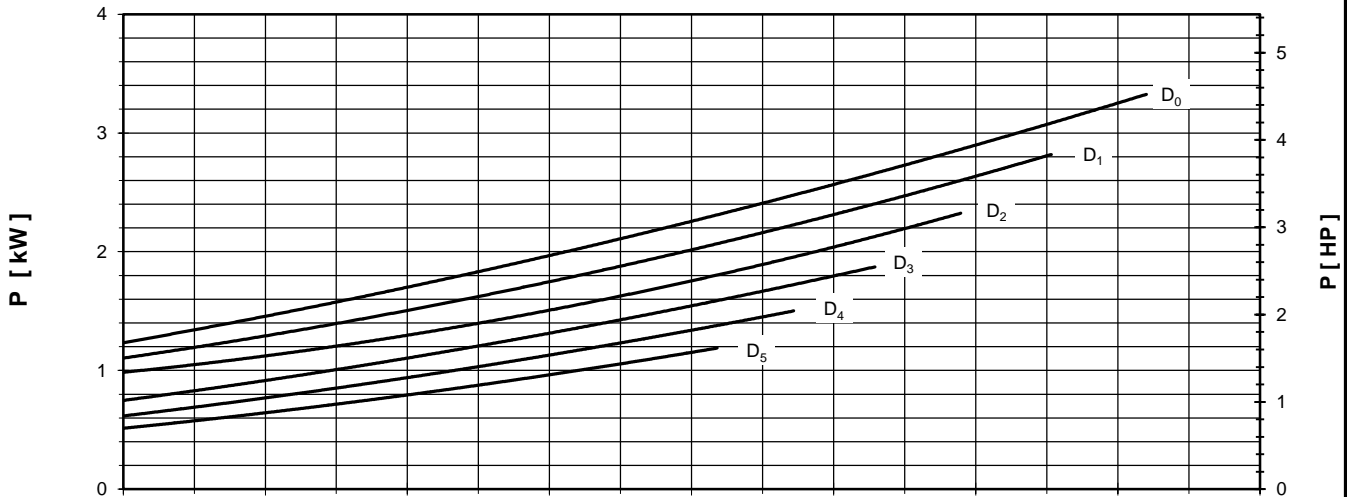
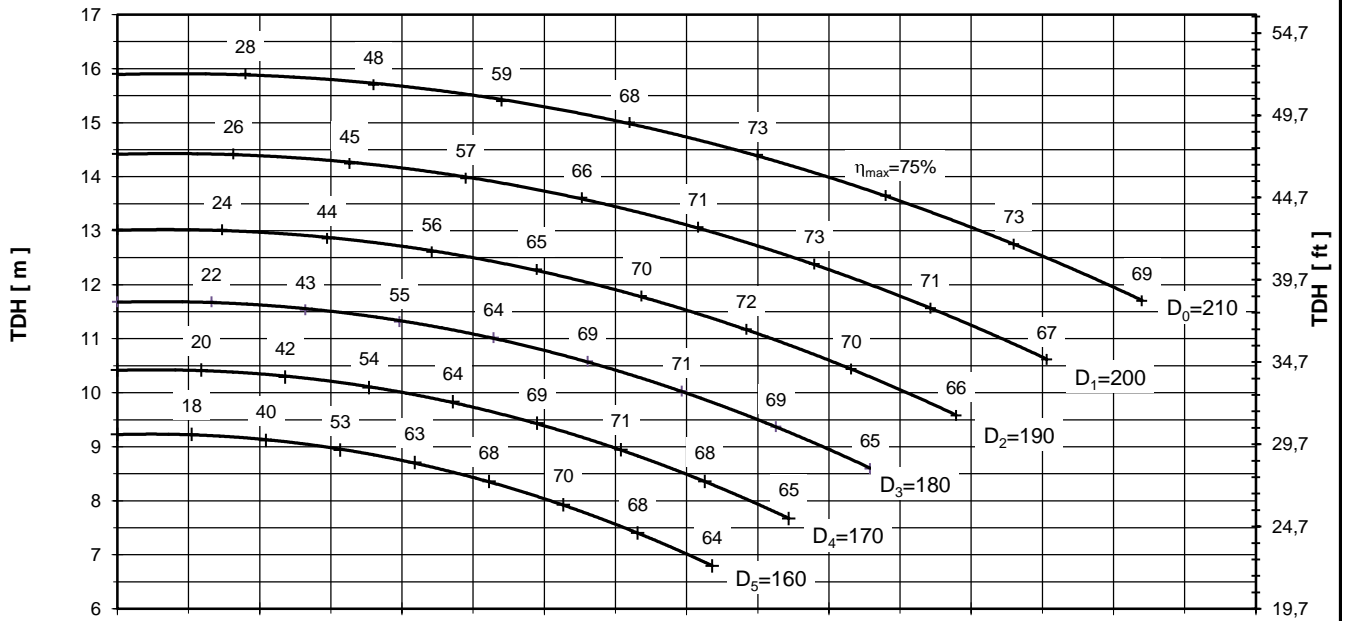

Performance curves are valid for clean cold water-kinematic viscosity 1 [mm²/s], density 1000 [kg/m³]. Methods and tolerances of presented performance curves are in accordance with ISO 9906 - Annex A

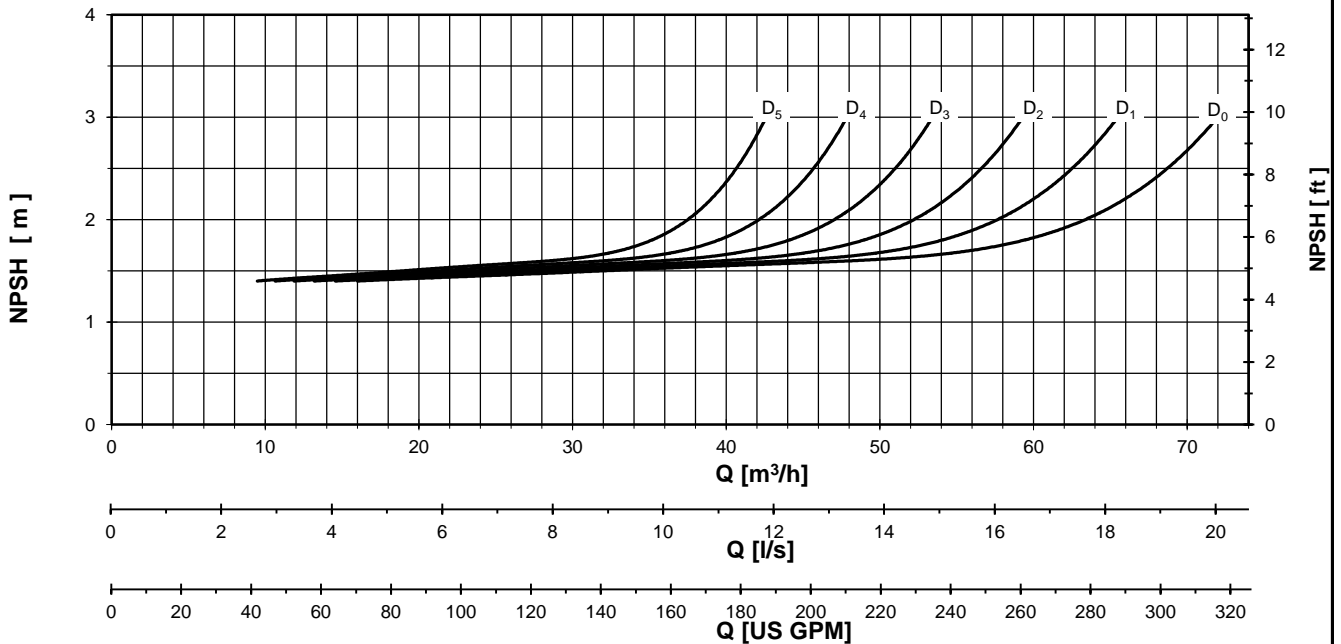
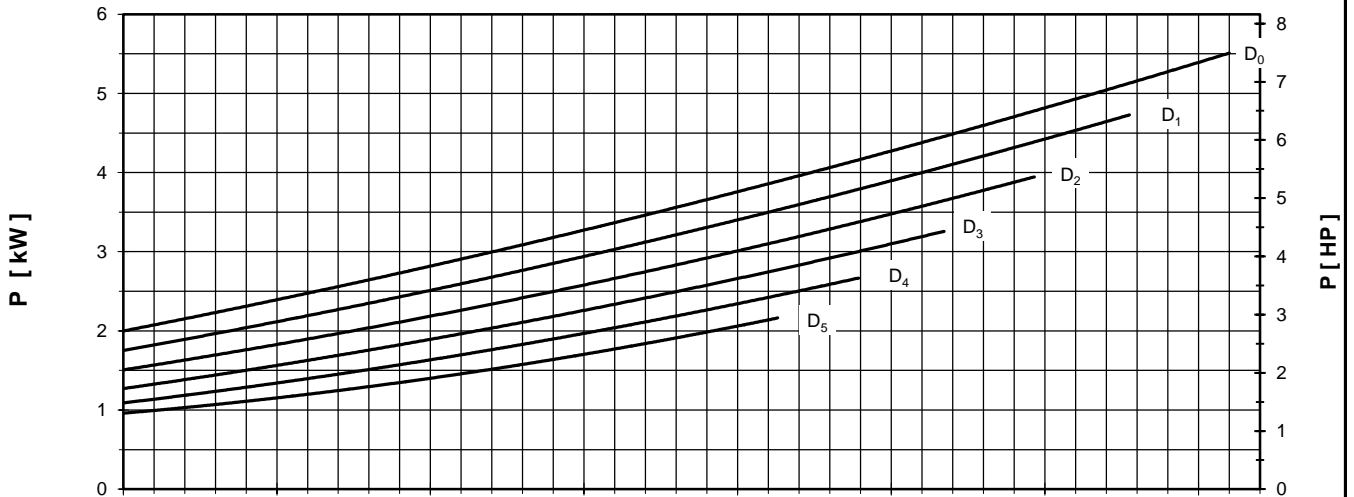
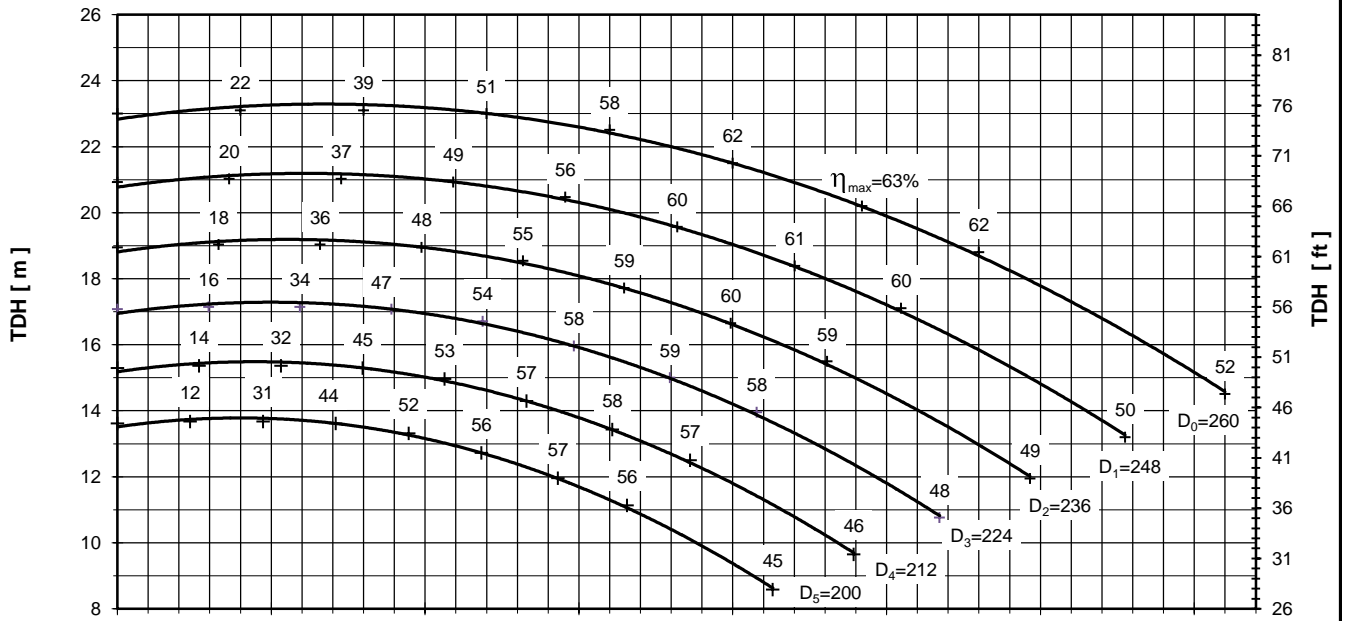

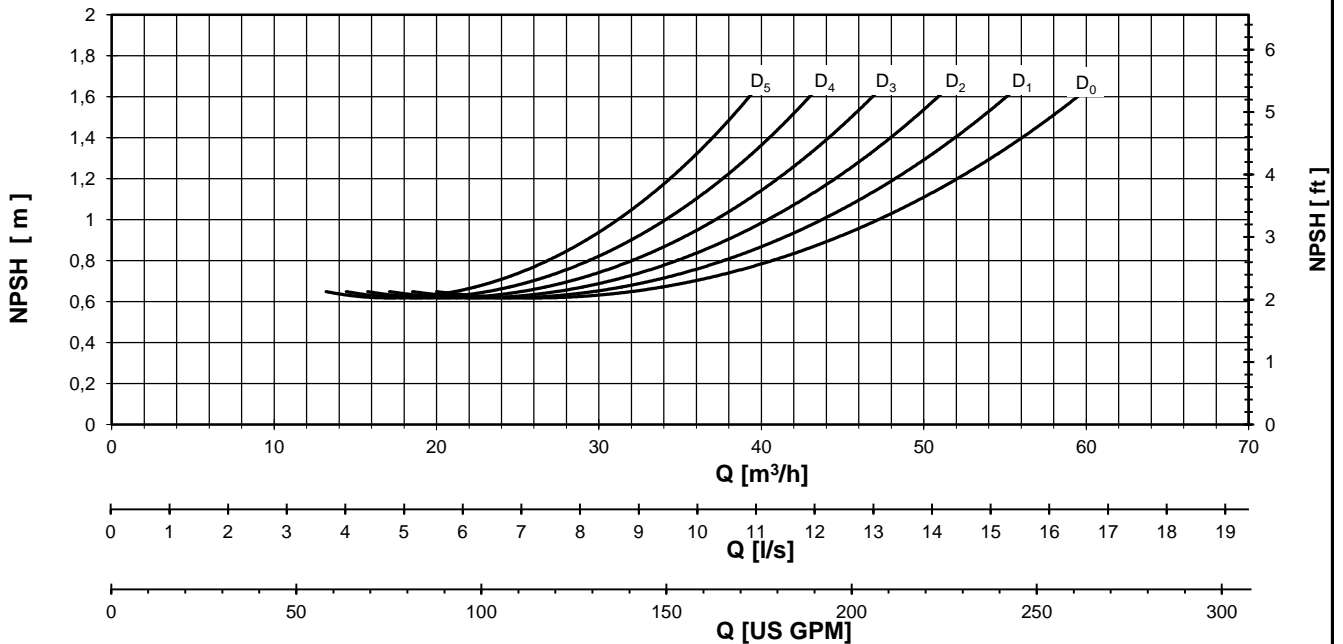
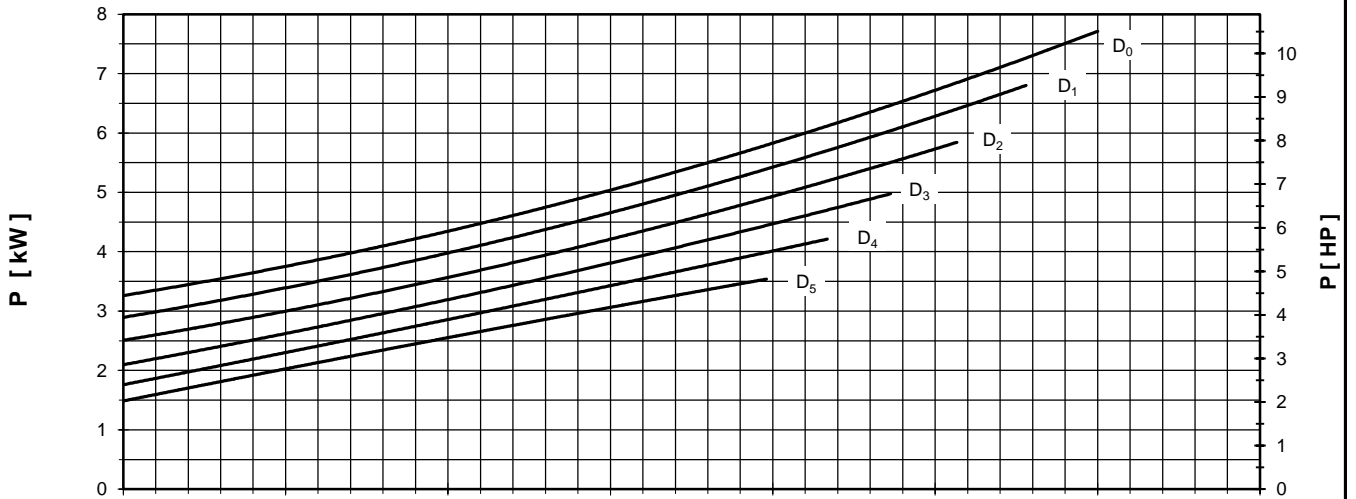
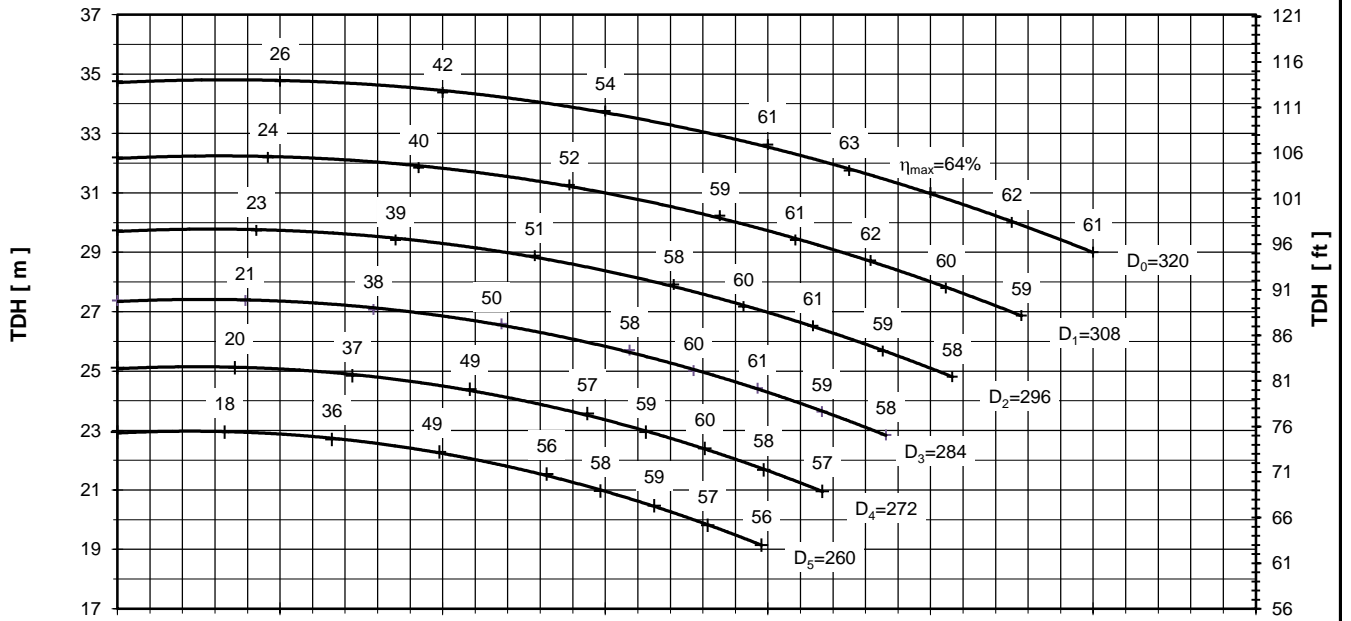



PUMP PERFORMANCE CURVES
No. 4HD.0160.03

PUMP TYPE
SCP 80 - 160
1450 [rpm]

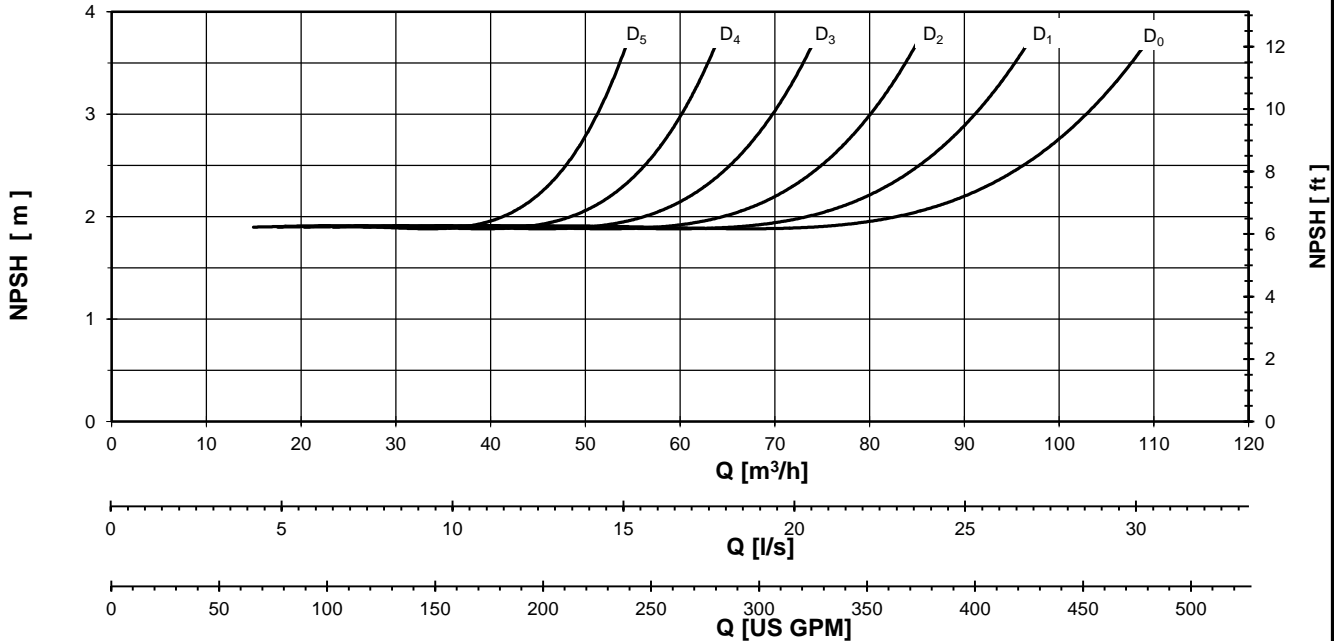
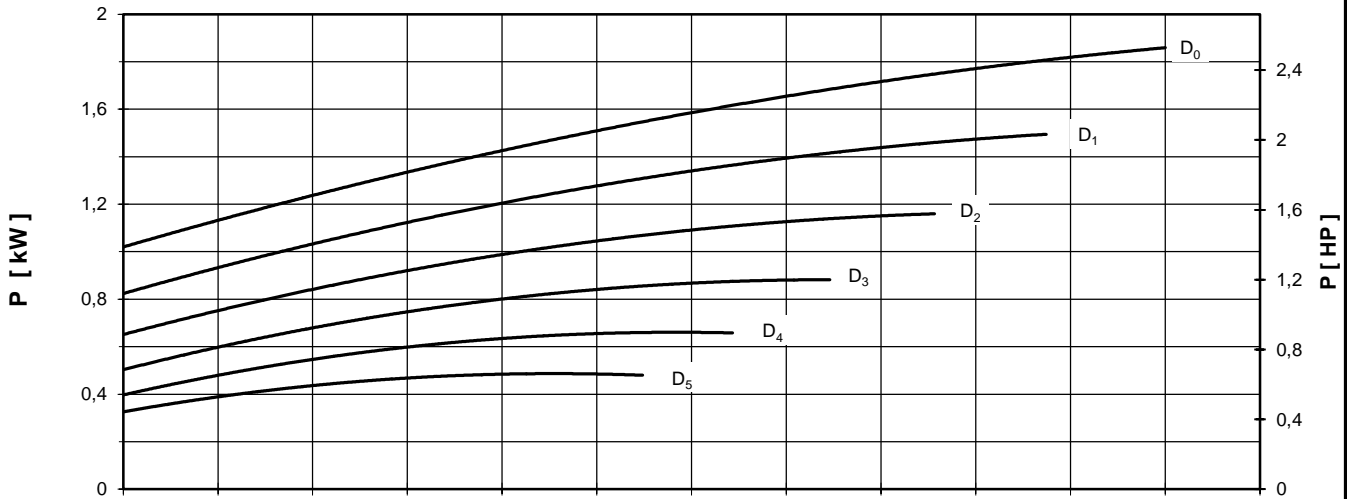
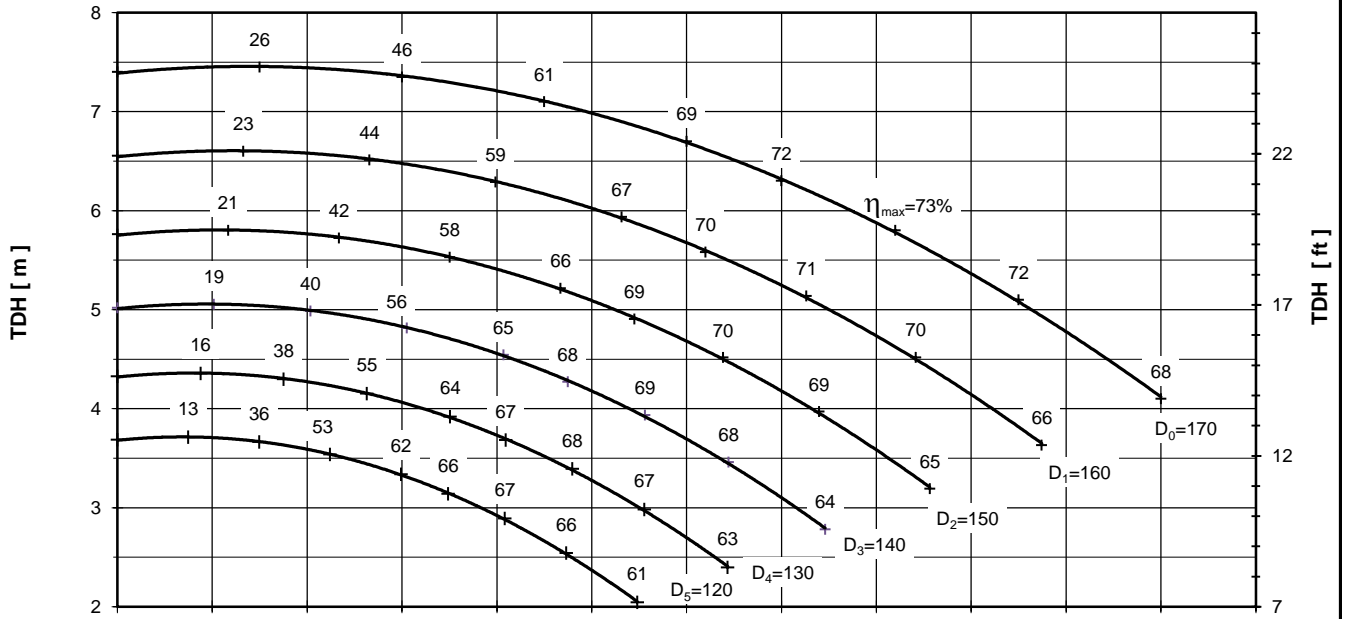

Performance curves are valid for clean cold water-kinematic viscosity 1 [mm²/s], density 1000 [kg/m³]. Methods and tolerances of presented performance curves are in accordance with ISO 9906 - Annex A



PUMP PERFORMANCE CURVES
No. 4HD.0161.03

PUMP TYPE
SCP 80 - 200
1450 [rpm]

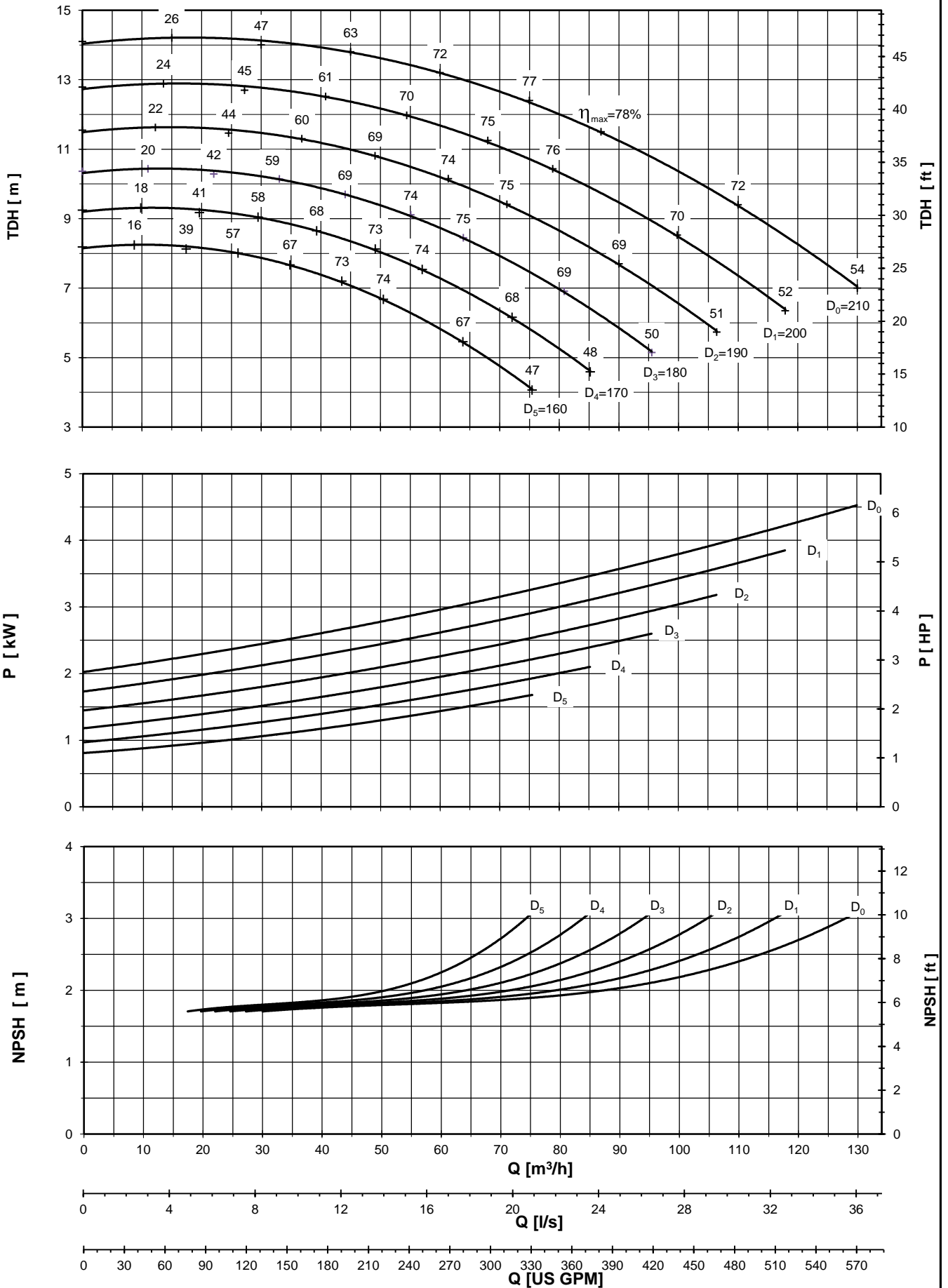

Performance curves are valid for clean cold water-kinematic viscosity 1 [mm²/s], density 1000 [kg/m³]. Methods and tolerances of presented performance curves are in accordance with ISO 9906 - Annex A

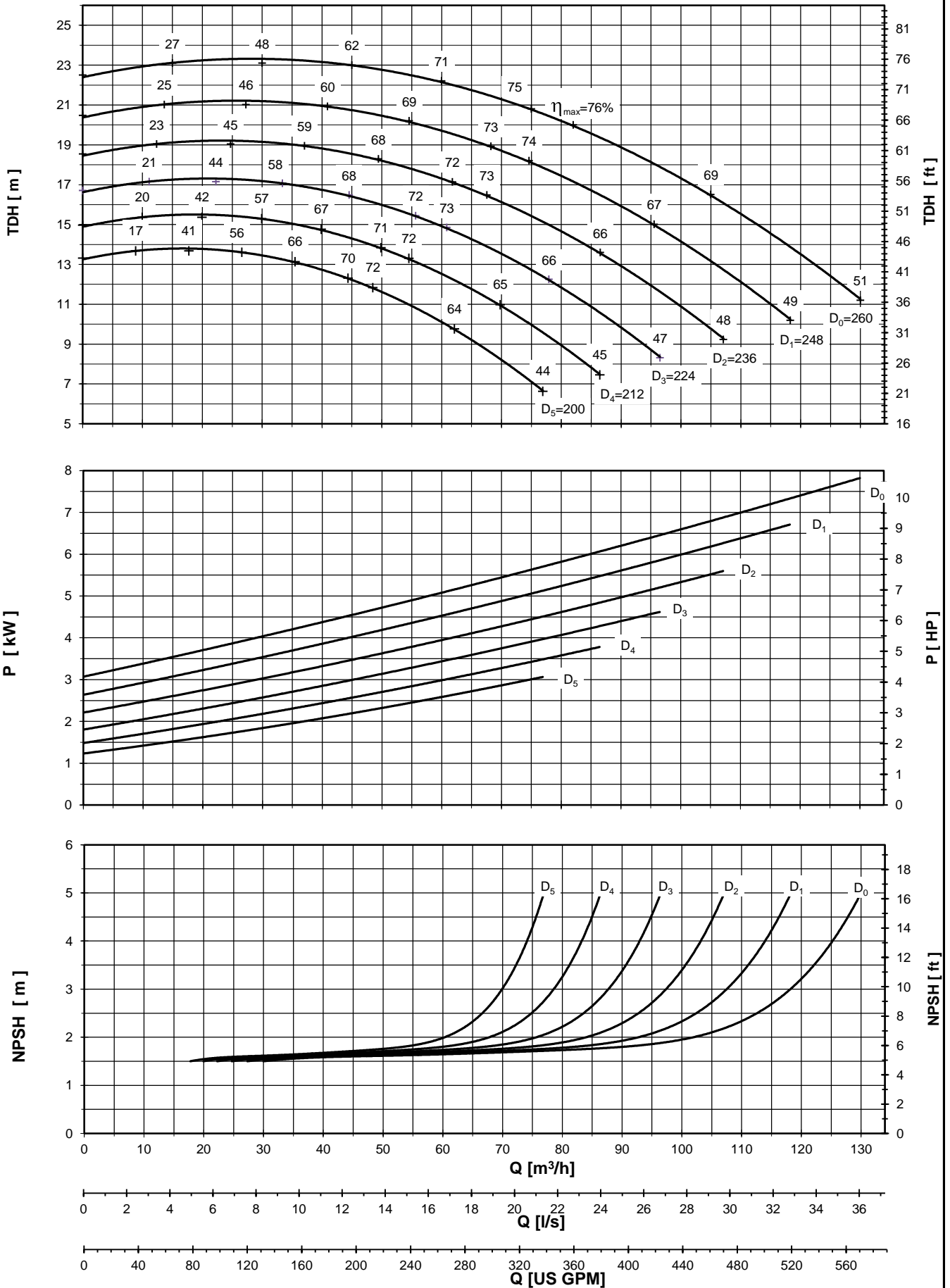

Performance curves are valid for clean cold water-kinematic viscosity 1 [mm²/s], density 1000 [kg/m³]. Methods and tolerances of presented performance curves are in accordance with ISO 9906 - Annex A



PUMP PERFORMANCE CURVES
No. 4HD.0163.03

PUMP TYPE
SCP 80 - 315
1450 [rpm]

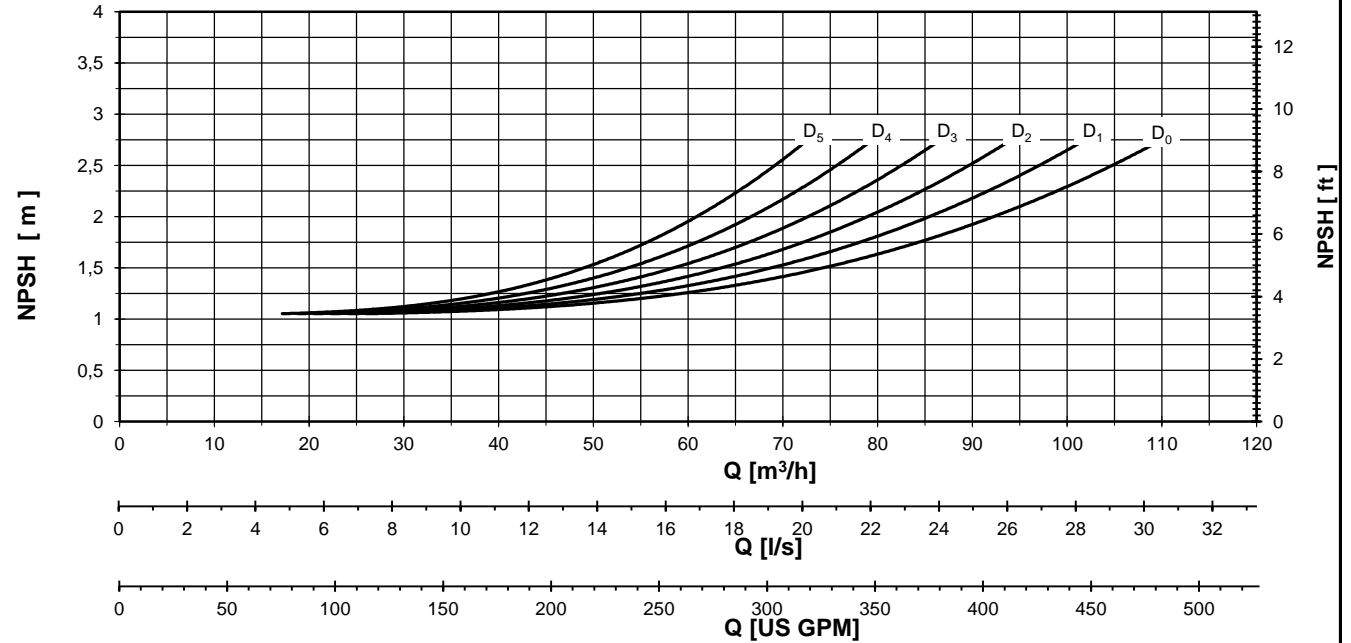
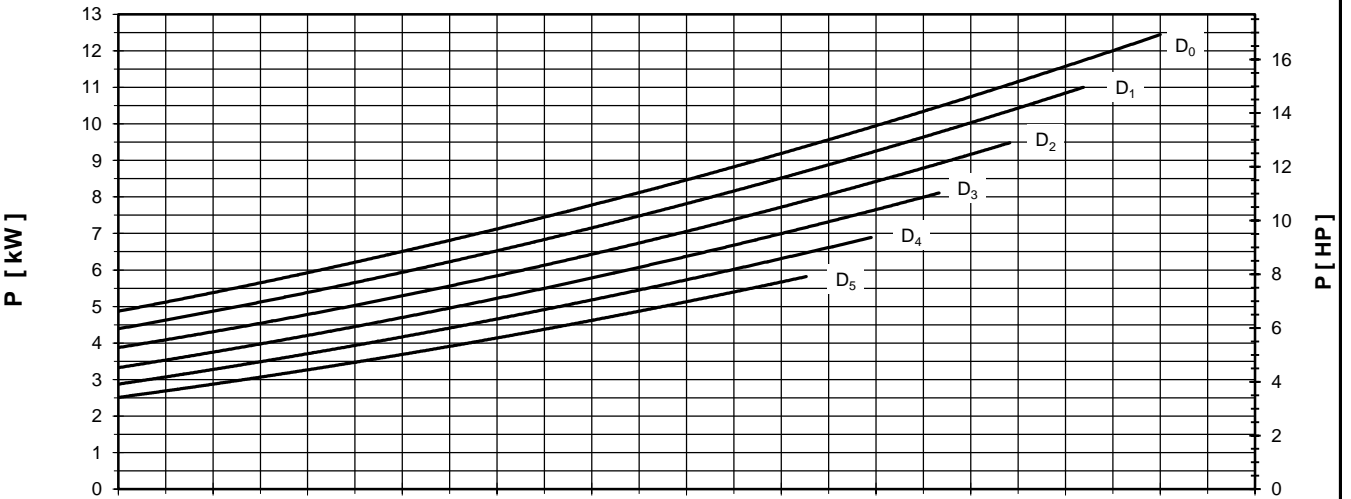
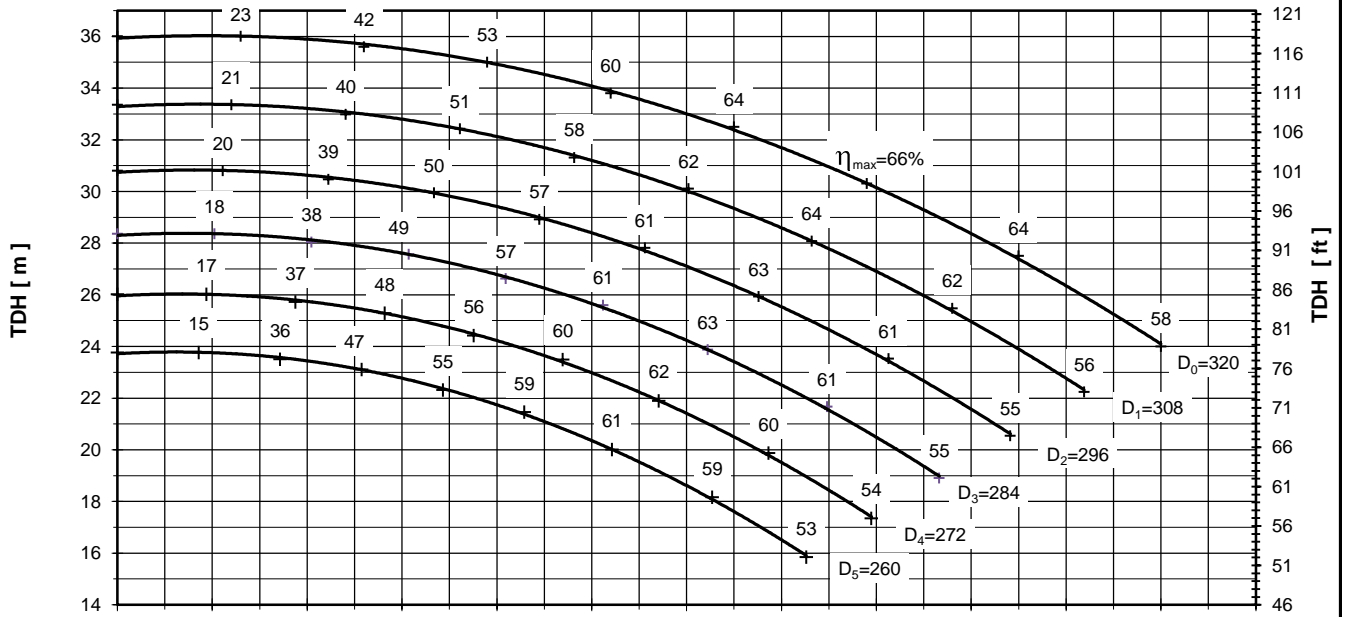

Performance curves are valid for clean cold water-kinematic viscosity 1 [mm²/s], density 1000 [kg/m³]. Methods and tolerances of presented performance curves are in accordance with ISO 9906 - Annex A



PUMP PERFORMANCE CURVES
No. 4HD.0164.03

PUMP TYPE
SCP 80 - 400
1450 [rpm]

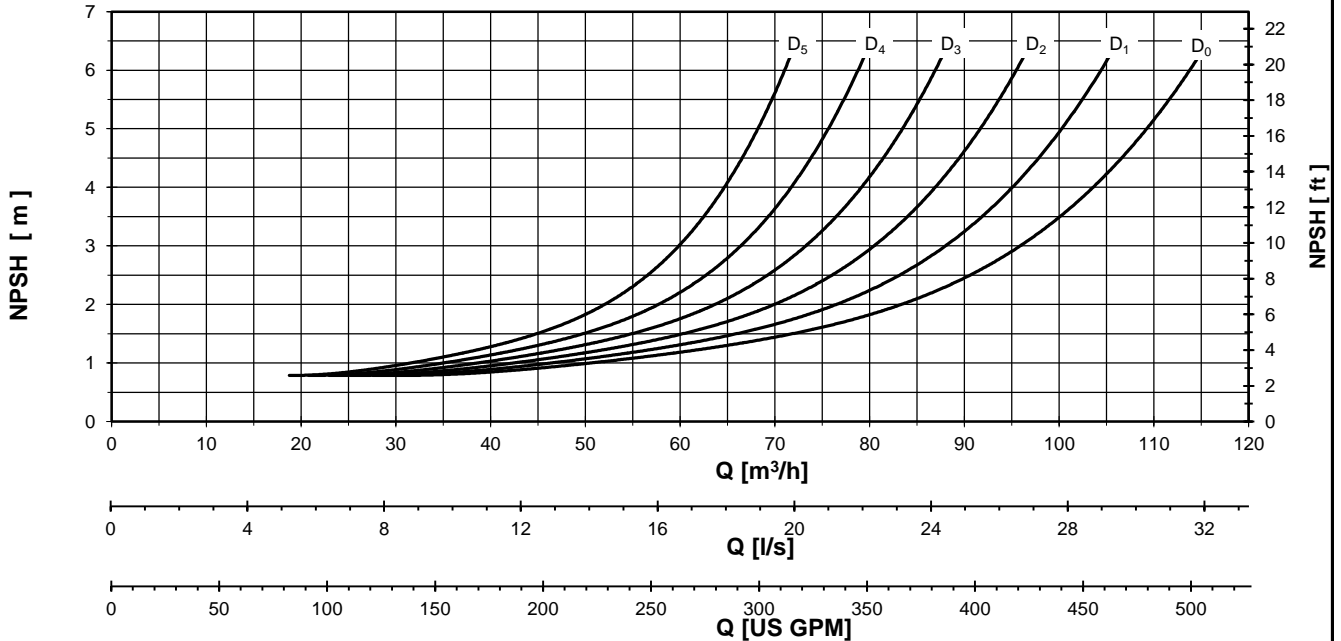
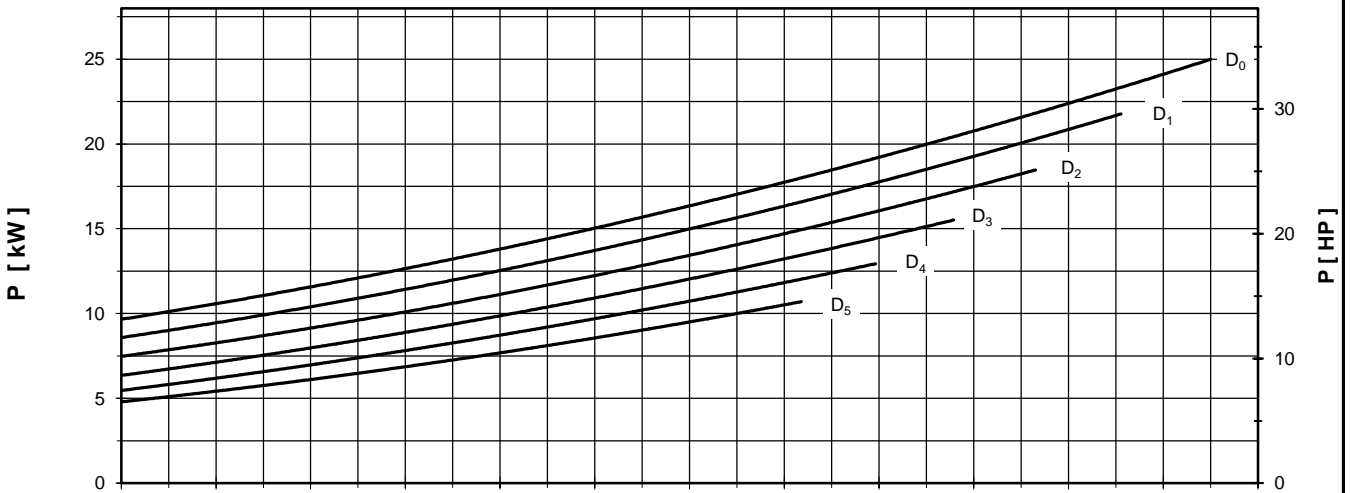
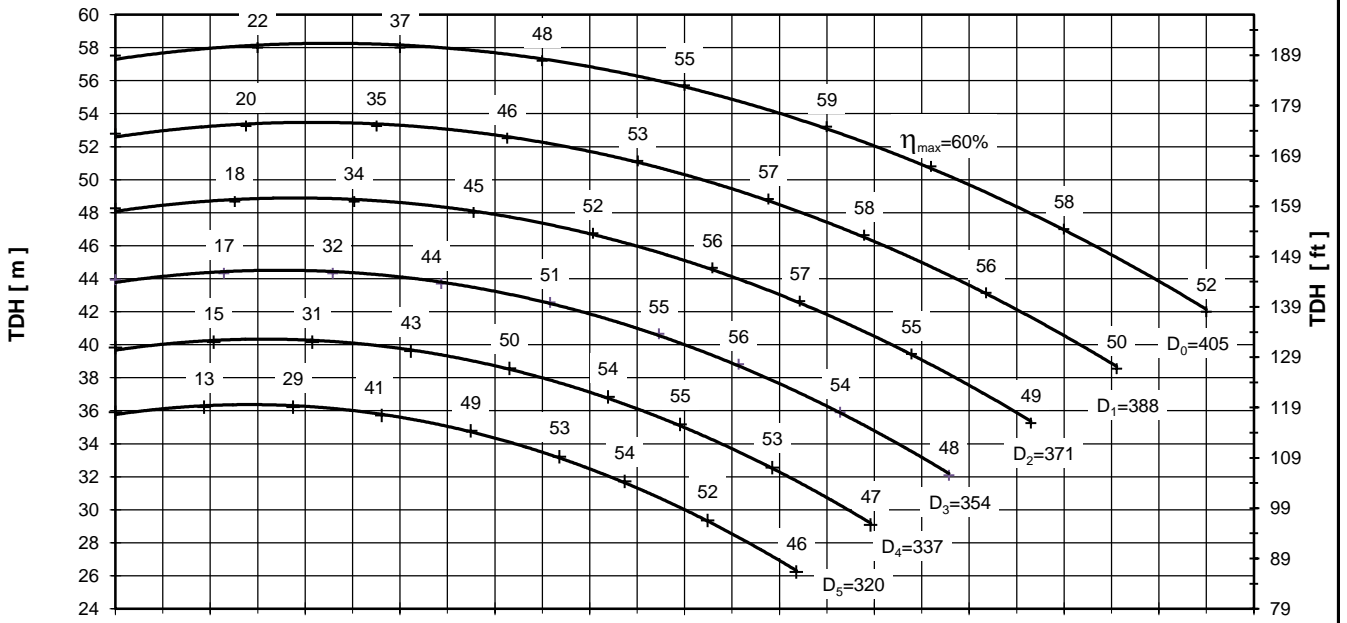

Performance curves are valid for clean cold water-kinematic viscosity 1 [mm²/s], density 1000 [kg/m³]. Methods and tolerances of presented performance curves are in accordance with ISO 9906 - Annex A

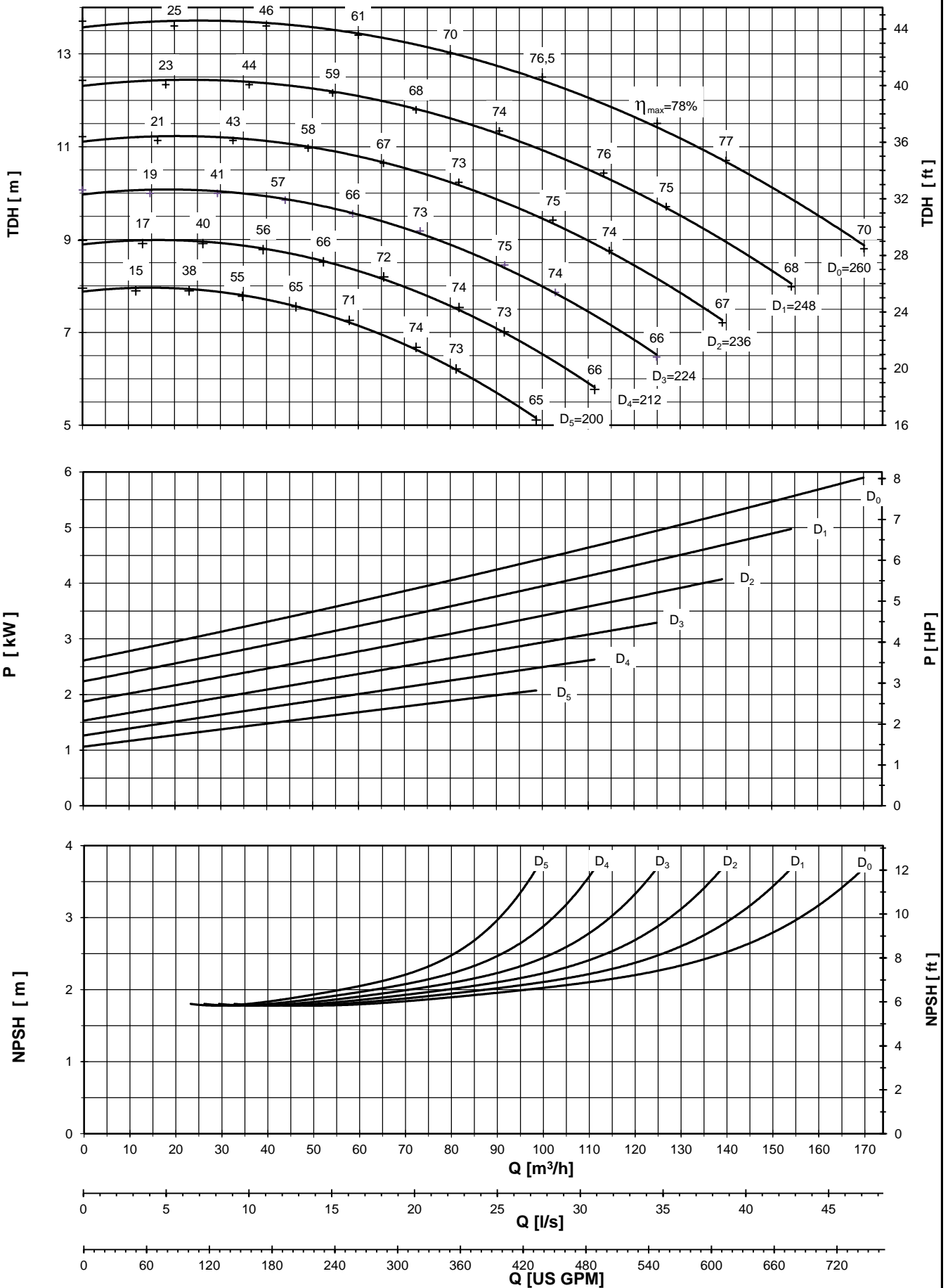

Performance curves are valid for clean cold water-kinematic viscosity 1 [mm²/s], density 1000 [kg/m³]. Methods and tolerances of presented performance curves are in accordance with ISO 9906 - Annex A

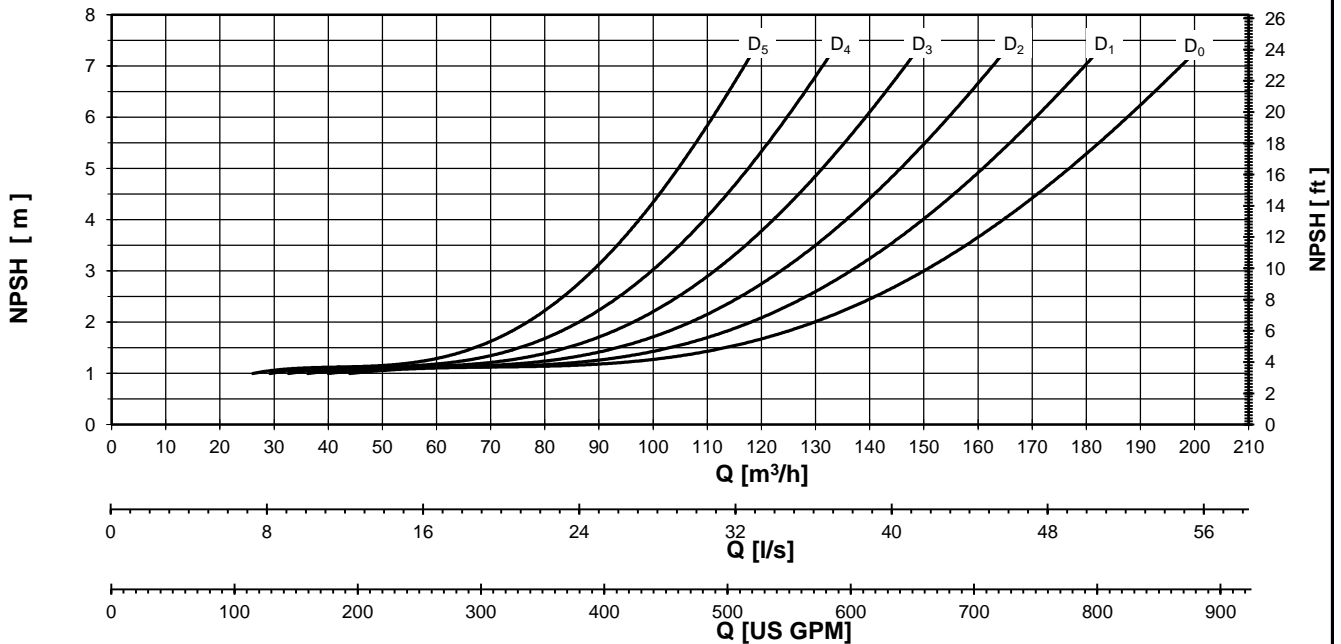
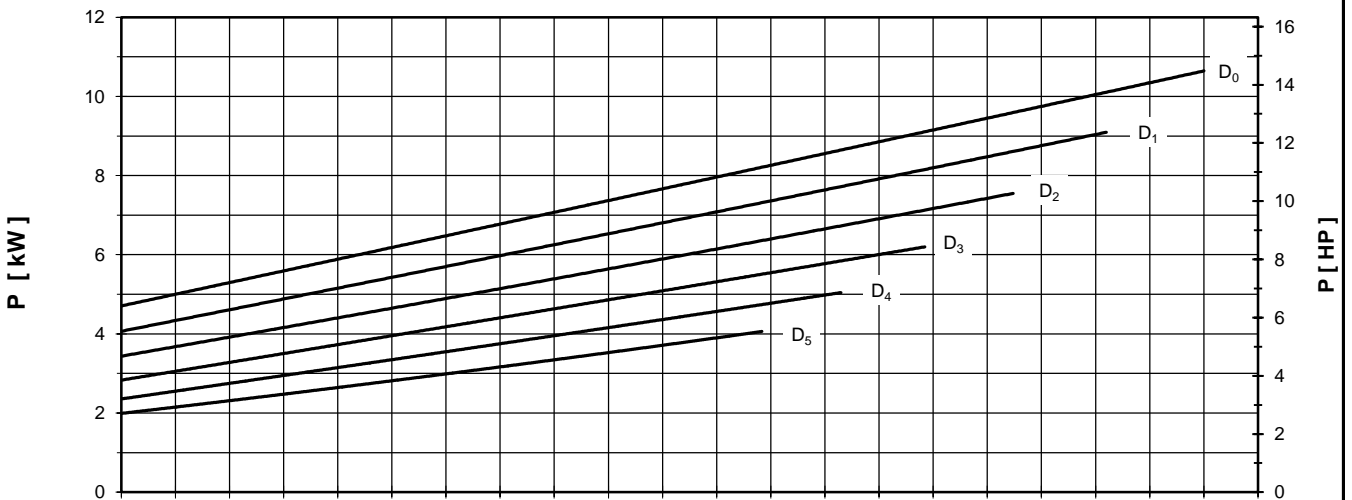
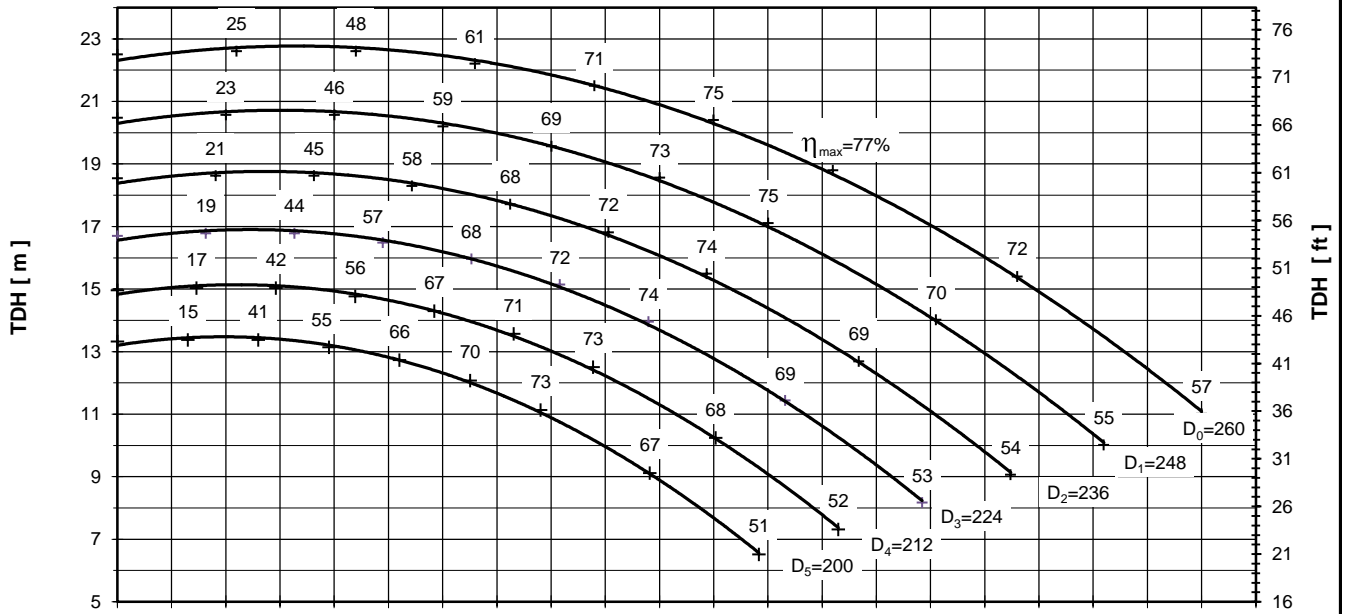



PUMP PERFORMANCE CURVES
No. 4HD.0167.03

PUMP TYPE
SCP 100 - 315
1450 [rpm]

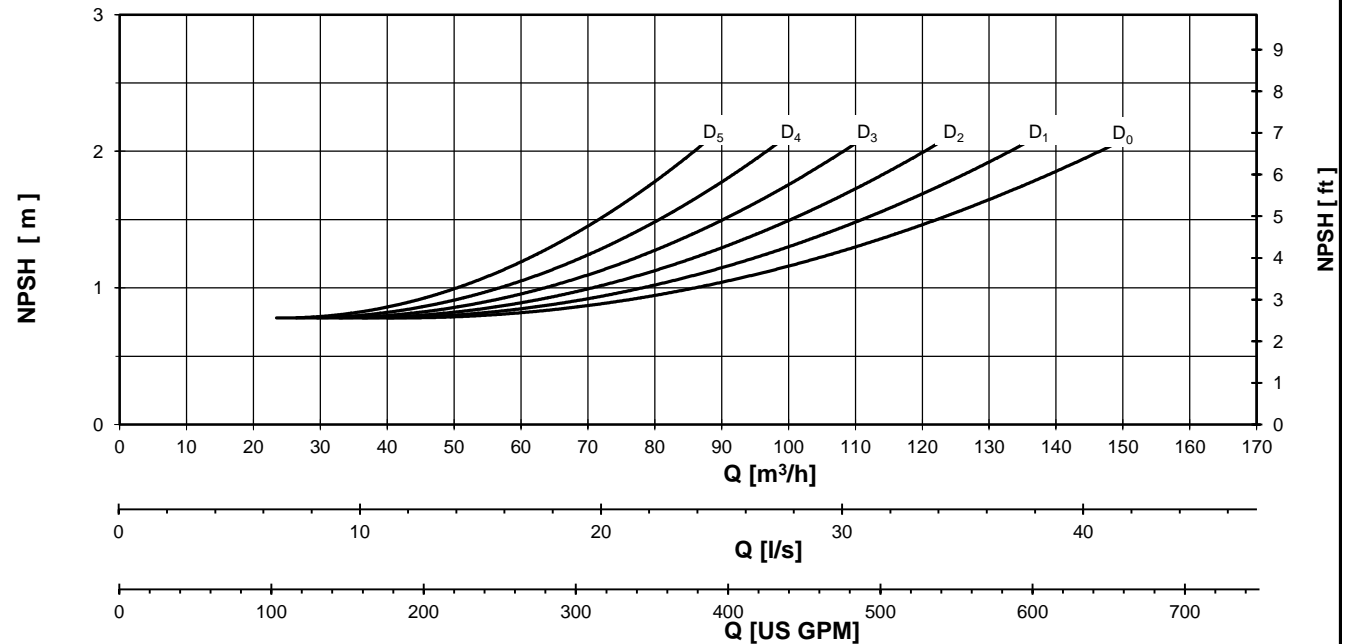
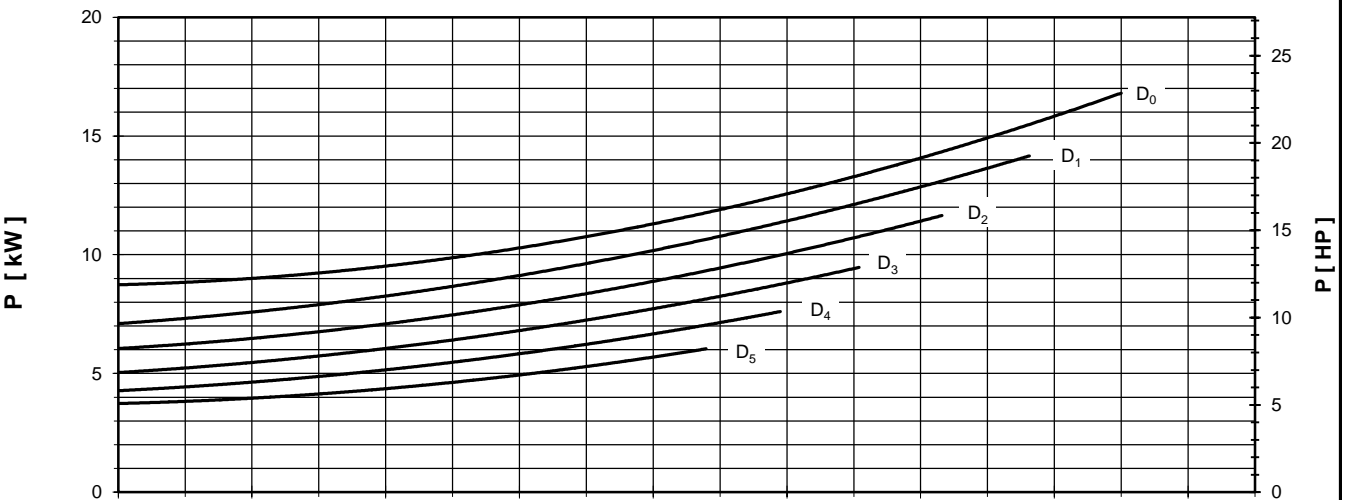
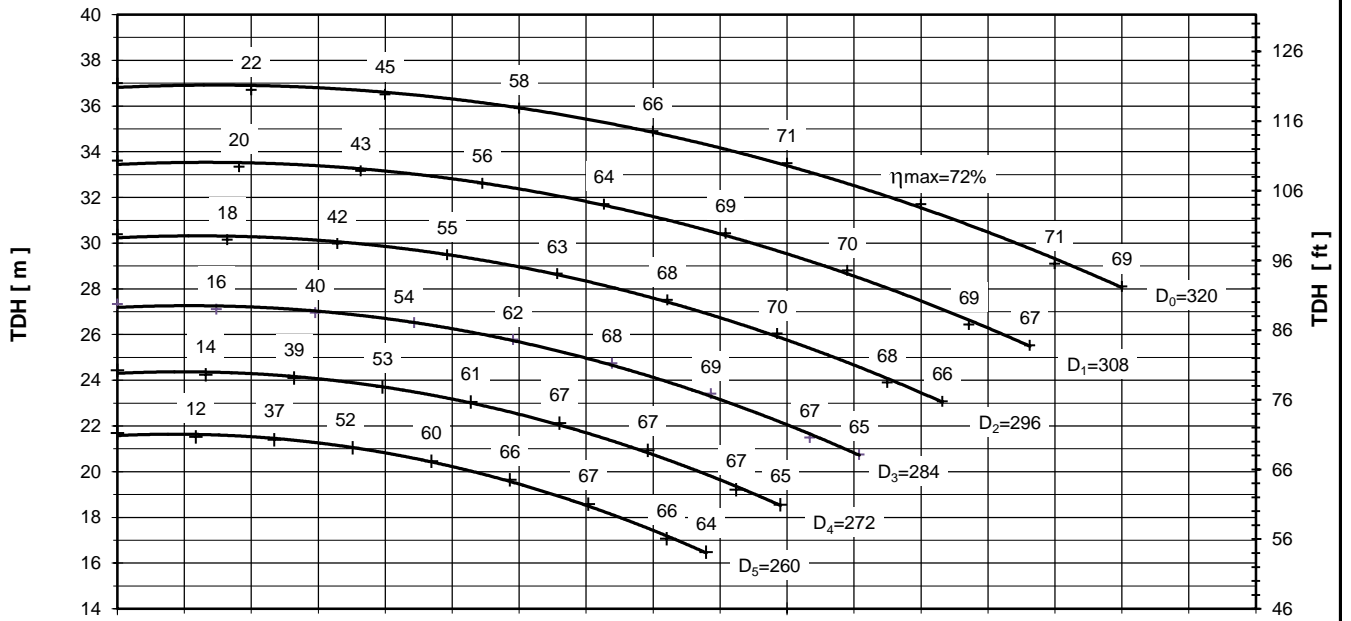

Performance curves are valid for clean cold water-kinematic viscosity 1 [mm²/s], density 1000 [kg/m³]. Methods and tolerances of presented performance curves are in accordance with ISO 9906 - Annex A

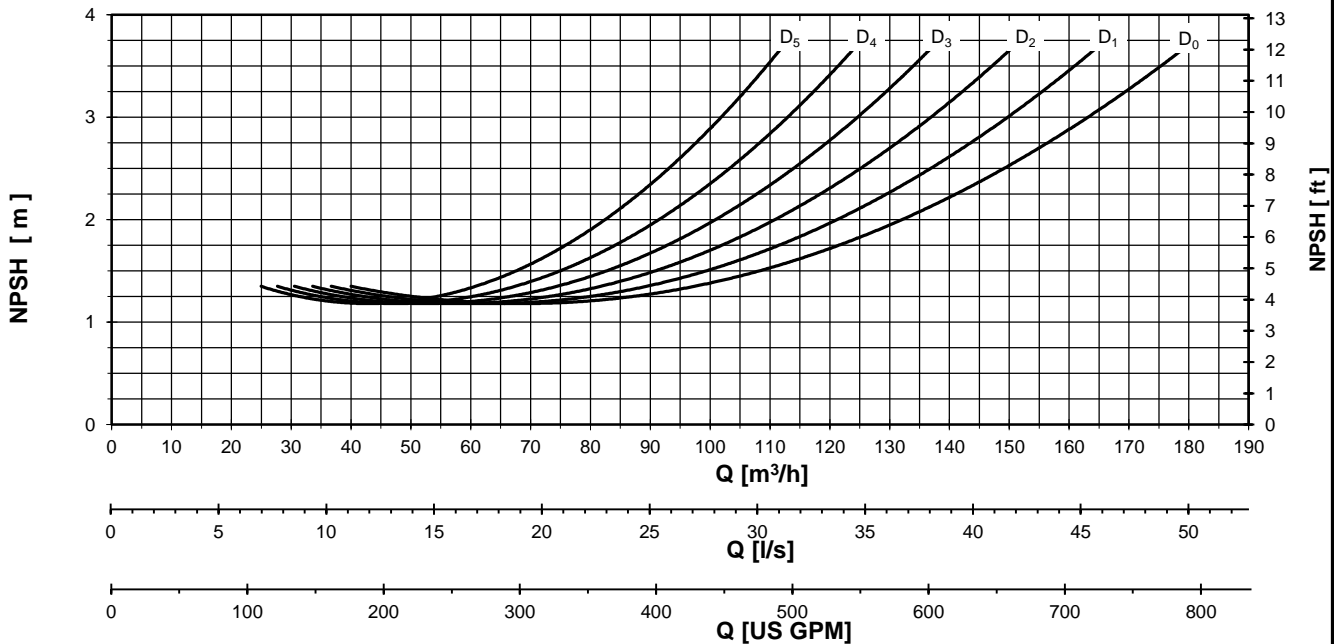
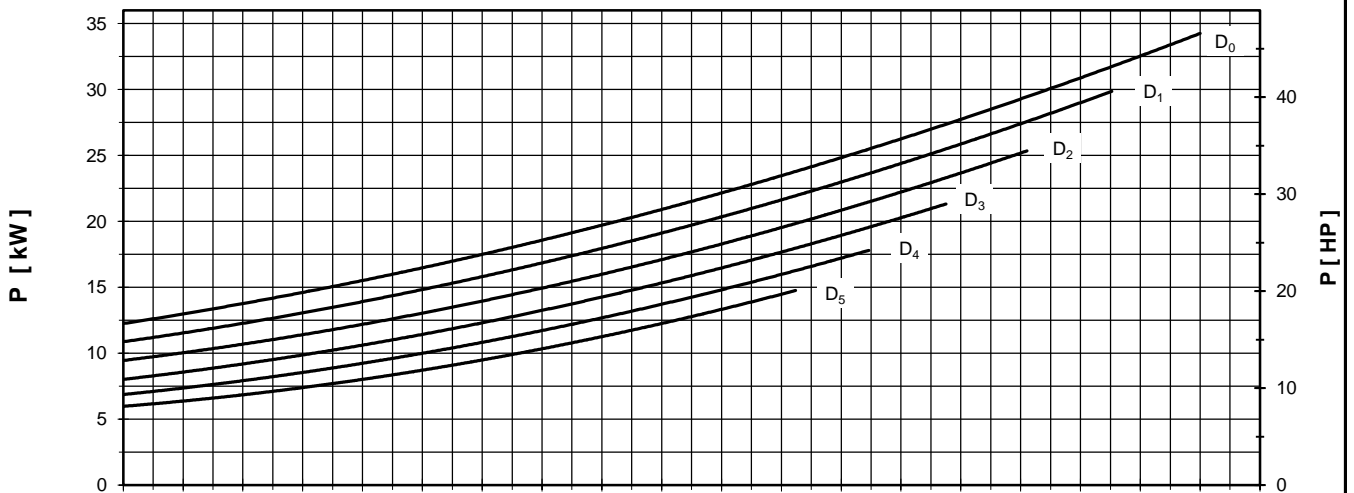
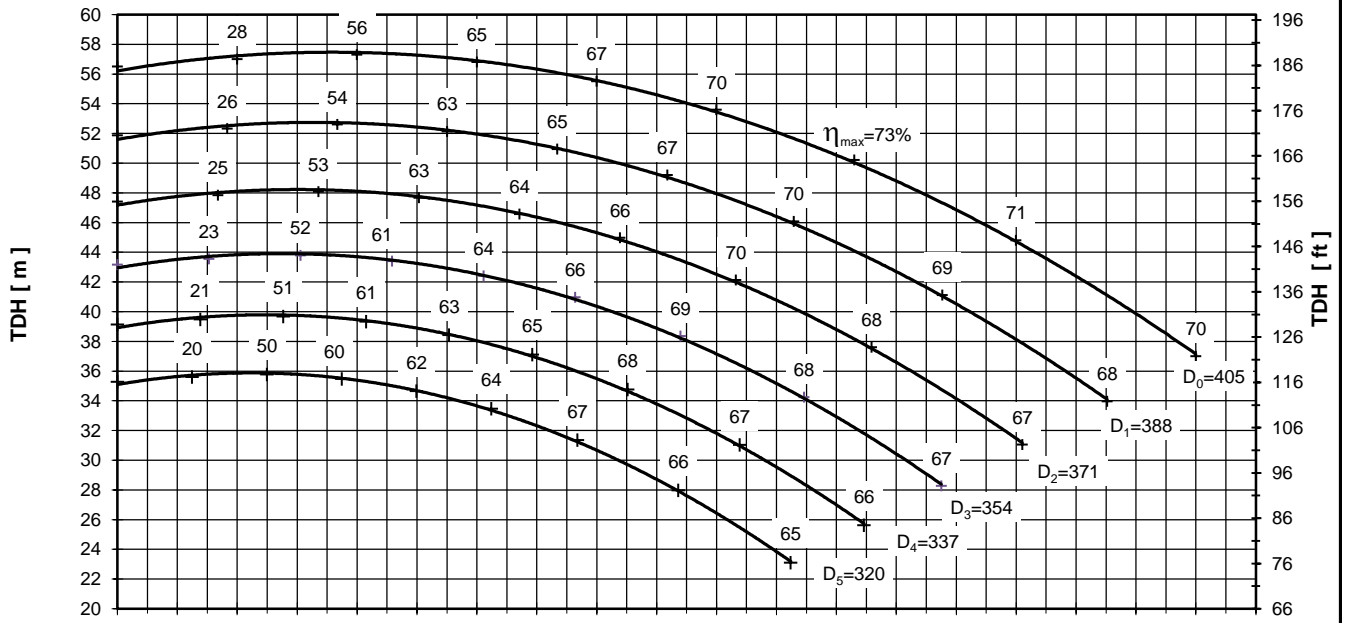

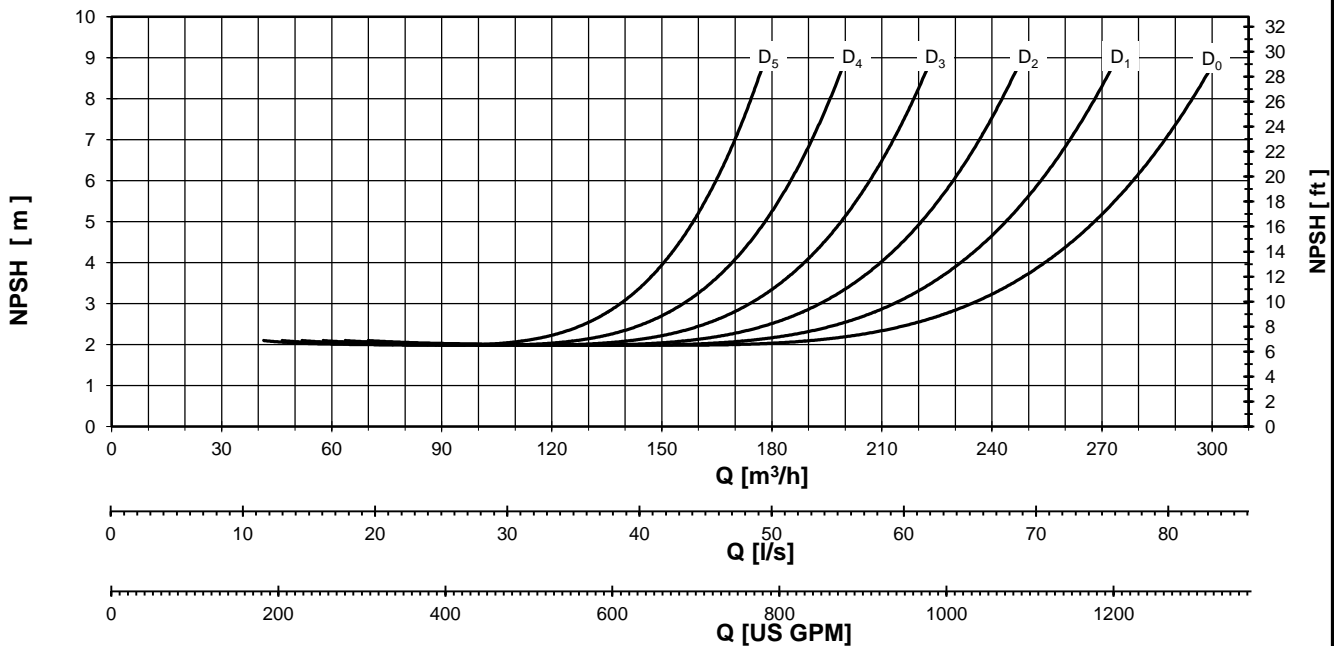
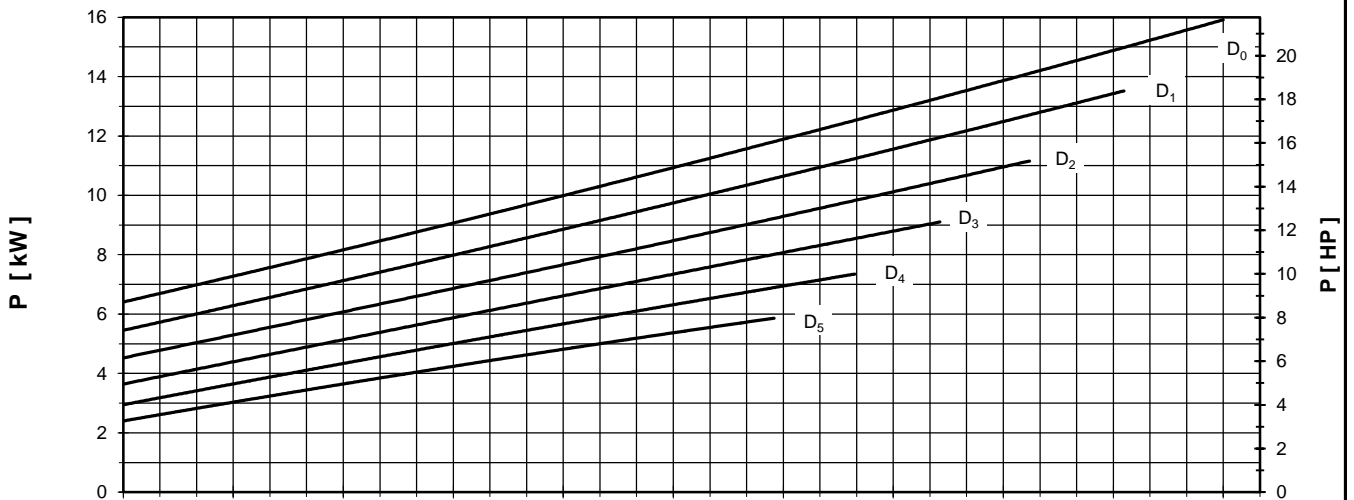
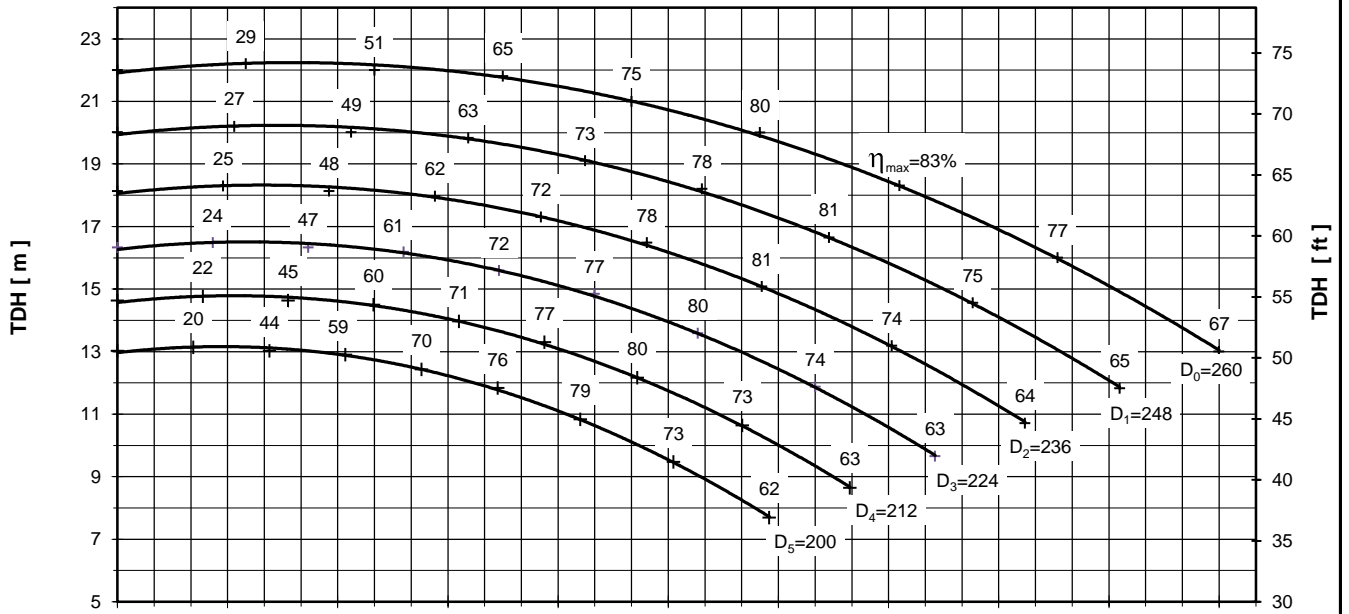

Performance curves are valid for clean cold water-kinematic viscosity 1 [mm²/s], density 1000 [kg/m³]. Methods and tolerances of presented performance curves are in accordance with ISO 9906 - Annex A



PUMP PERFORMANCE CURVES
No. 4HD.0170.03

PUMP TYPE
SCP 125 - 315
1450 [rpm]

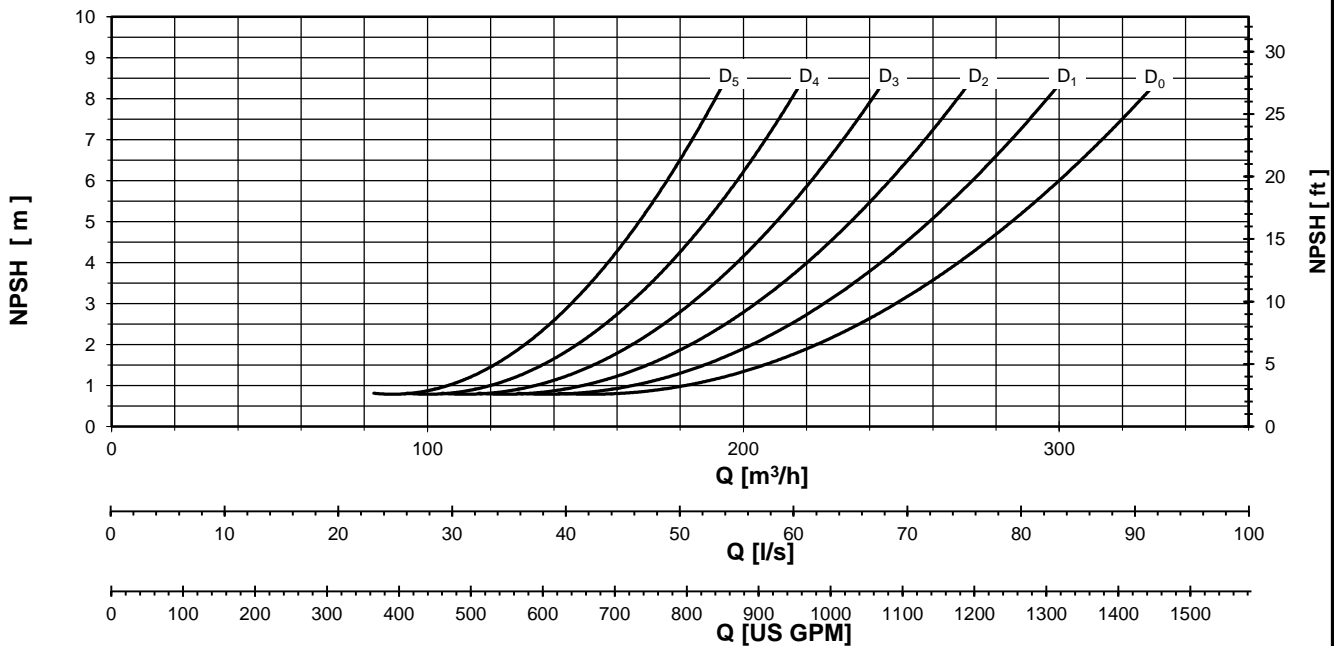
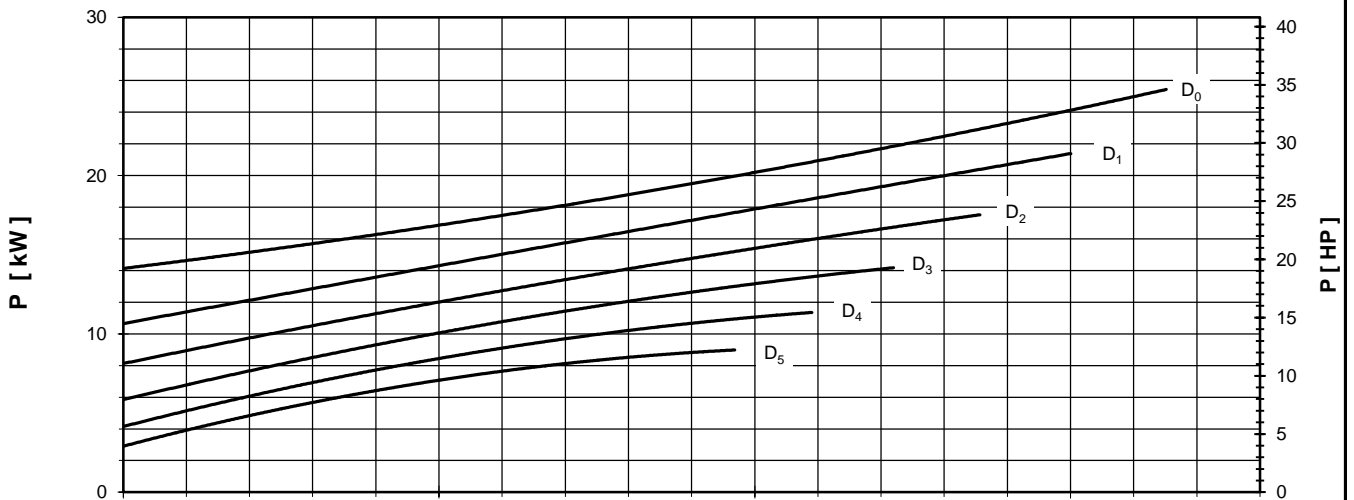
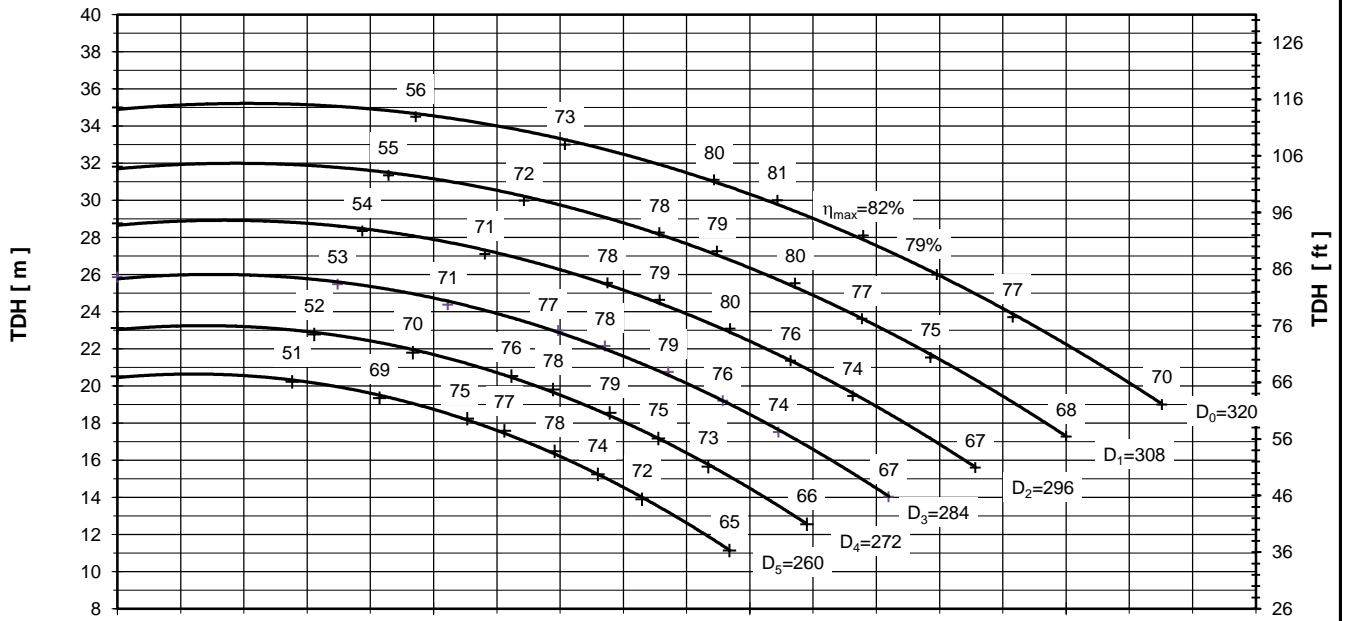

Performance curves are valid for clean cold water-kinematic viscosity 1 [mm²/s], density 1000 [kg/m³]. Methods and tolerances of presented performance curves are in accordance with ISO 9906 - Annex A

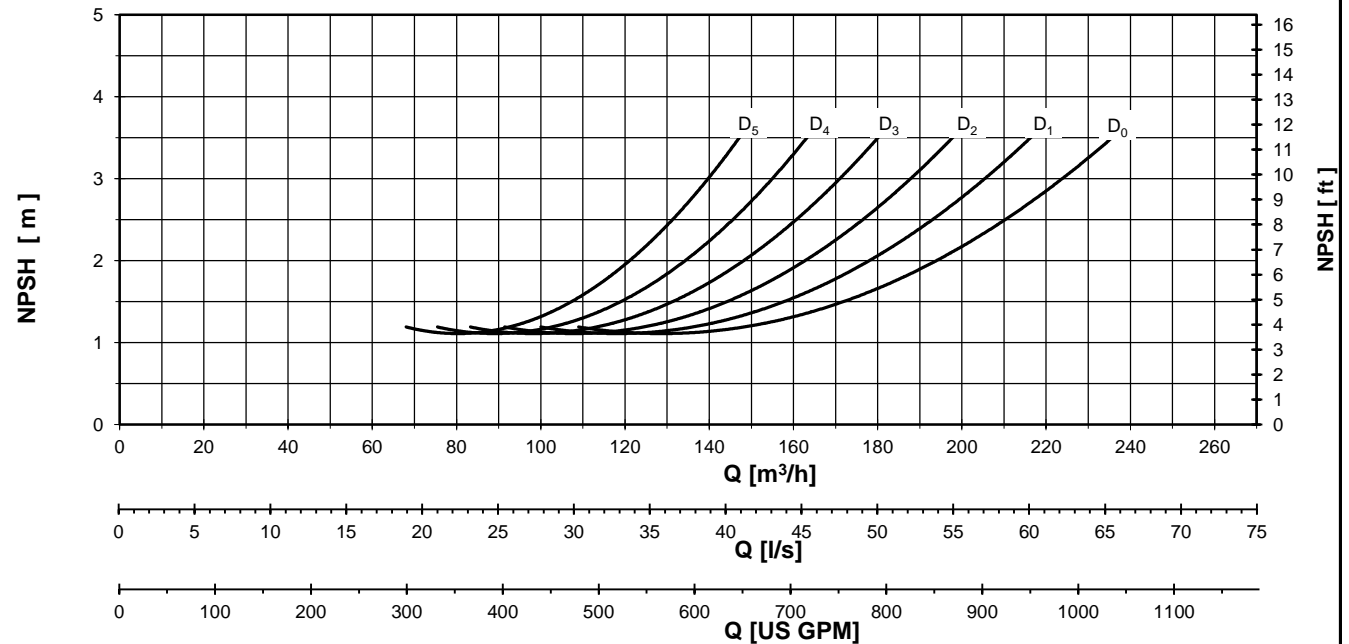
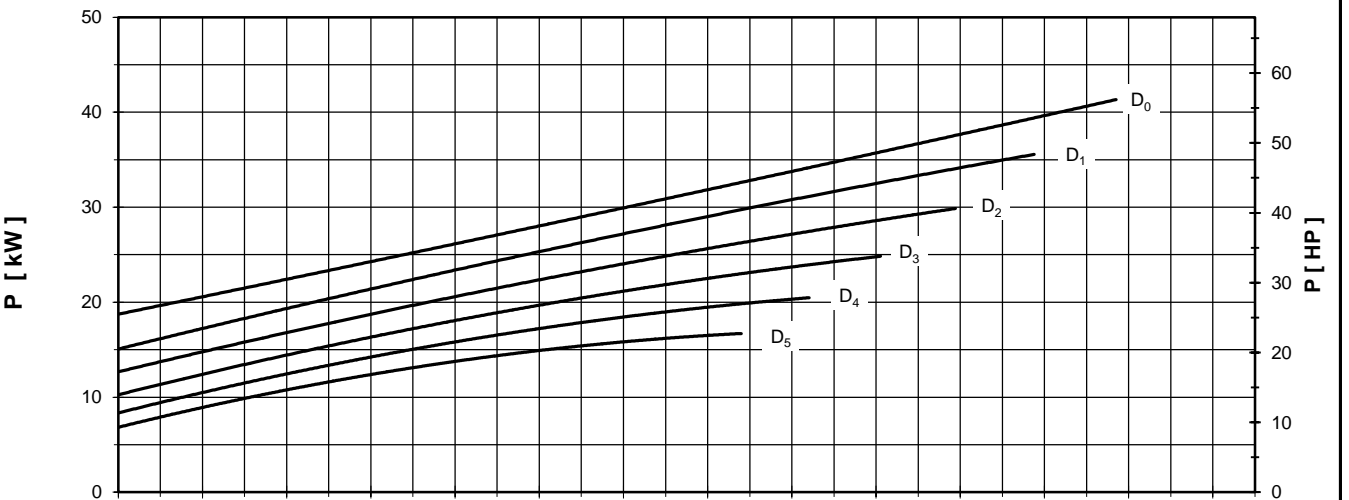
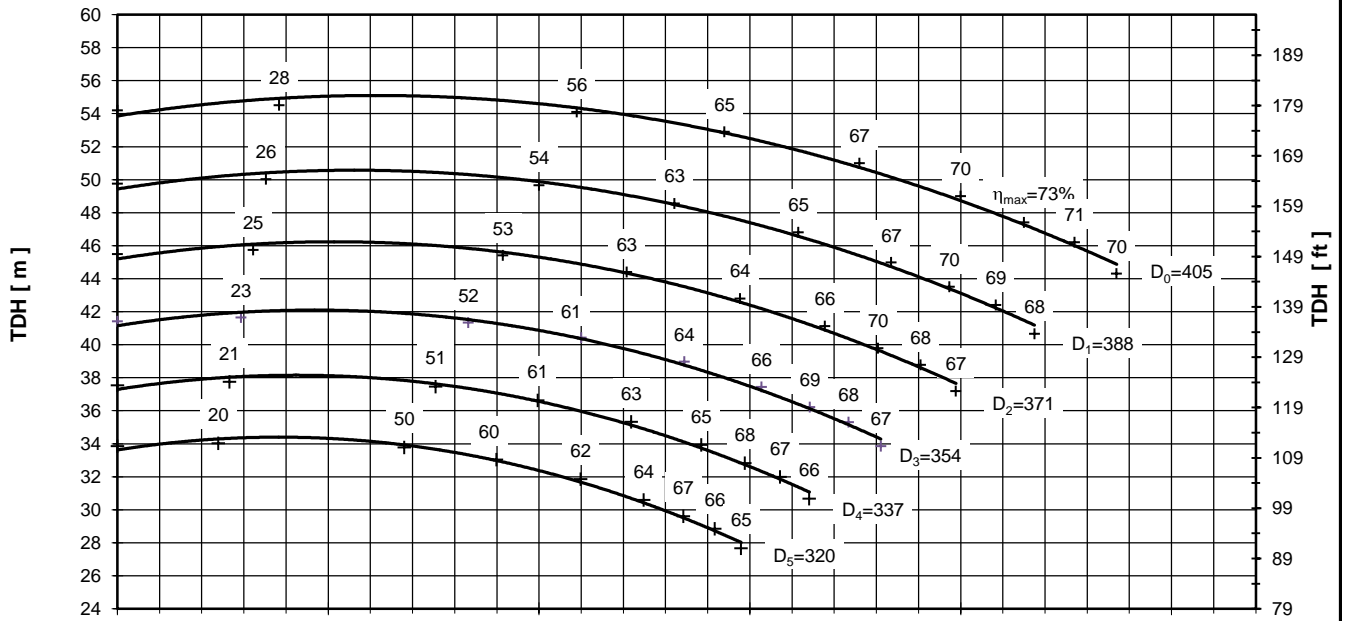

Performance curves are valid for clean cold water-kinematic viscosity 1 [mm²/s], density 1000 [kg/m³]. Methods and tolerances of presented performance curves are in accordance with ISO 9906 - Annex A



PUMP PERFORMANCE CURVES
No. 4HD.0172.03

PUMP TYPE
SCP 150 - 250
1450 [rpm]

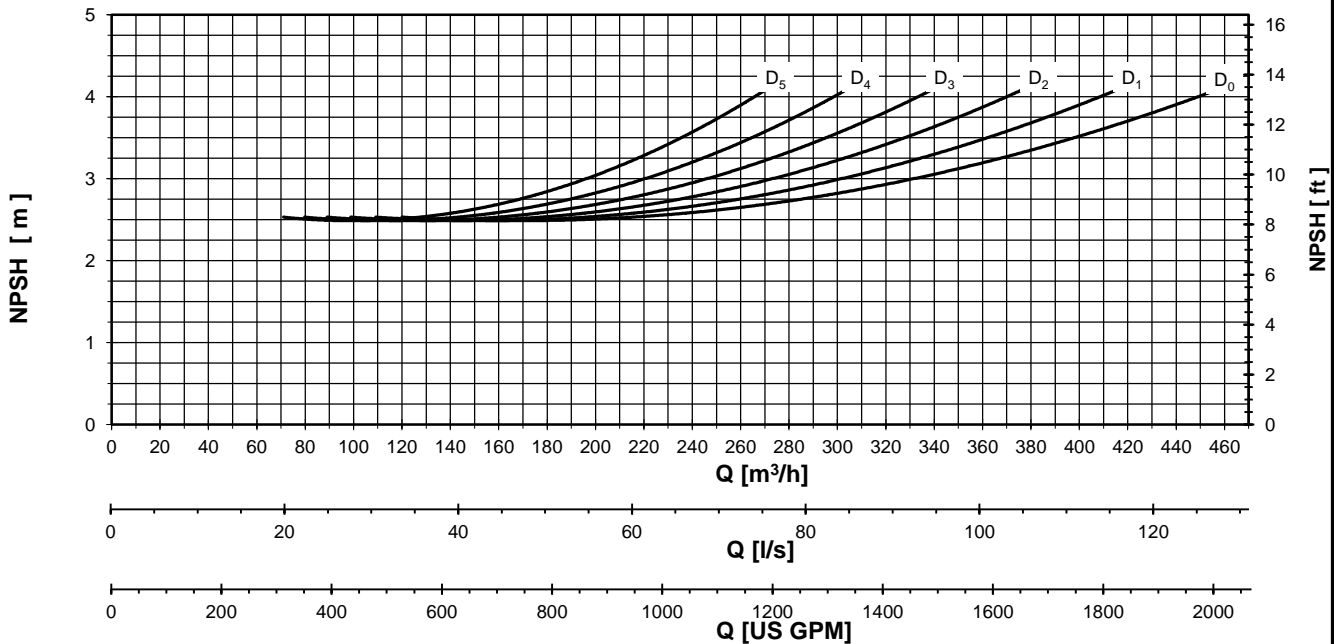
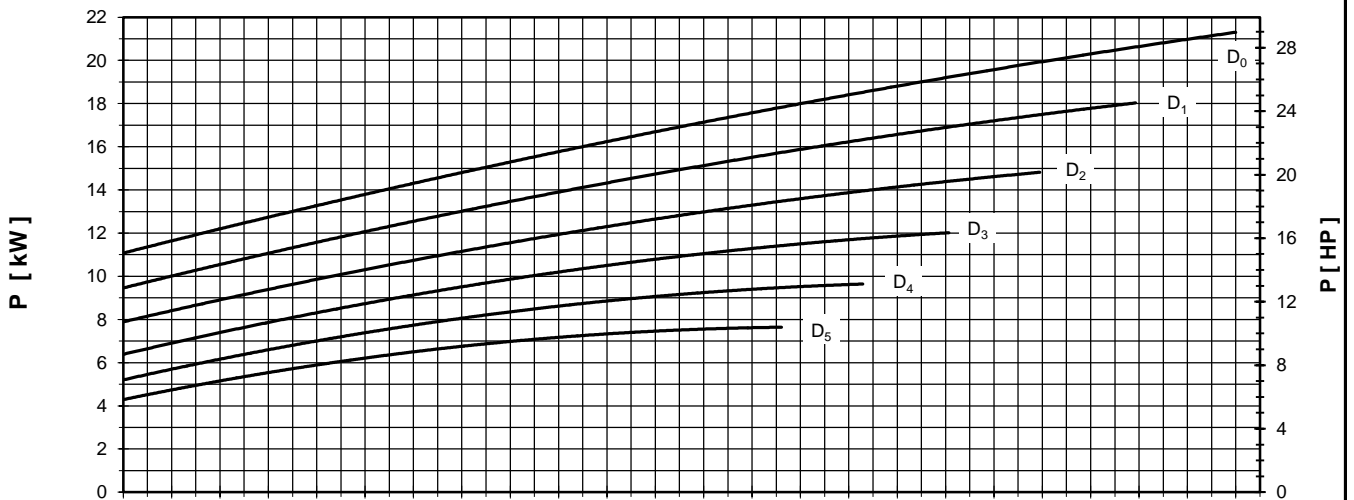
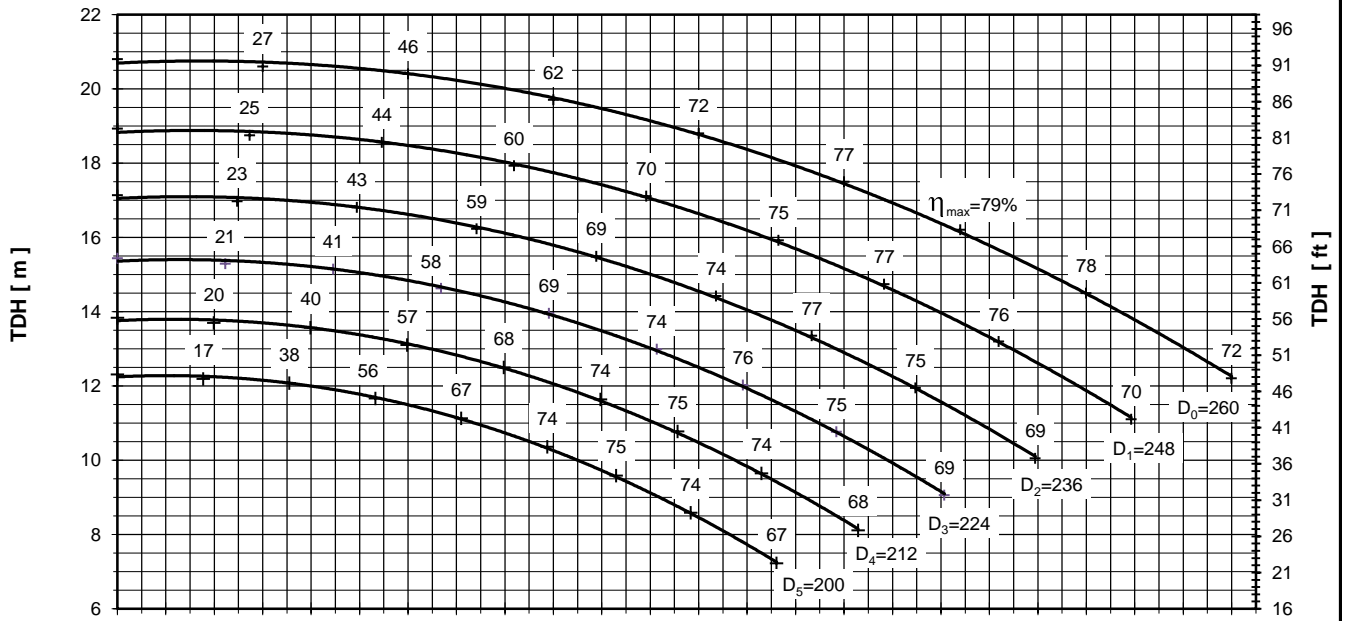

Performance curves are valid for clean cold water-kinematic viscosity 1 [mm²/s], density 1000 [kg/m³]. Methods and tolerances of presented performance curves are in accordance with ISO 9906 - Annex A

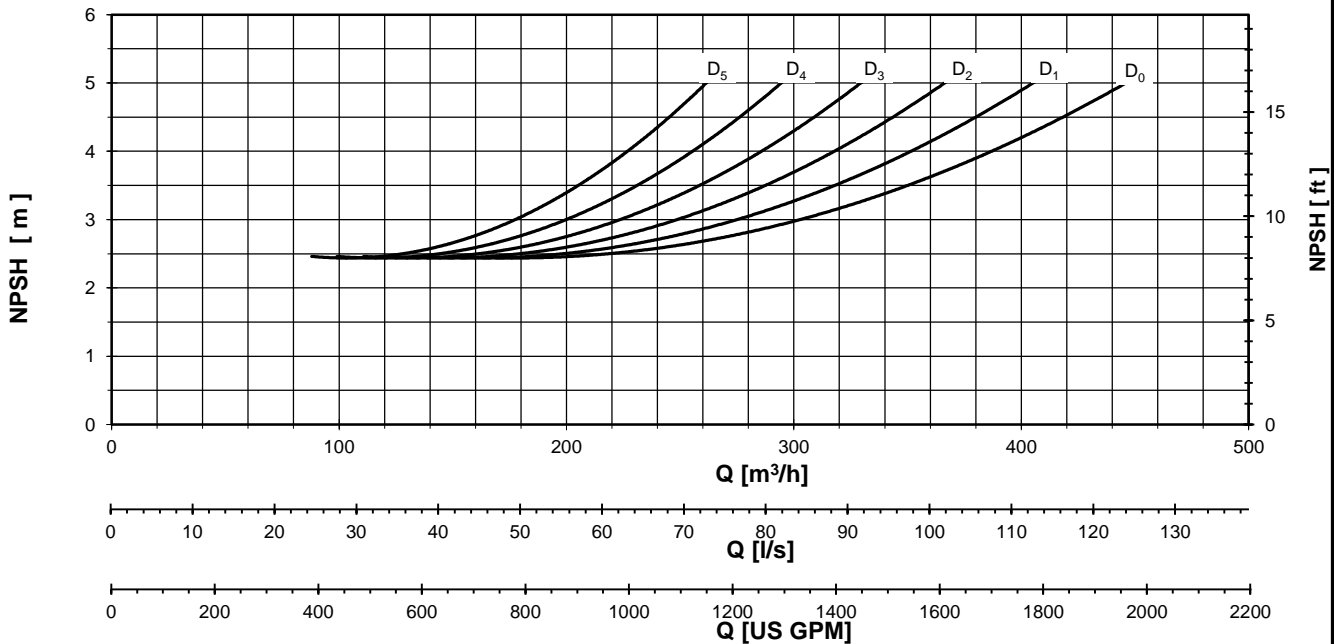
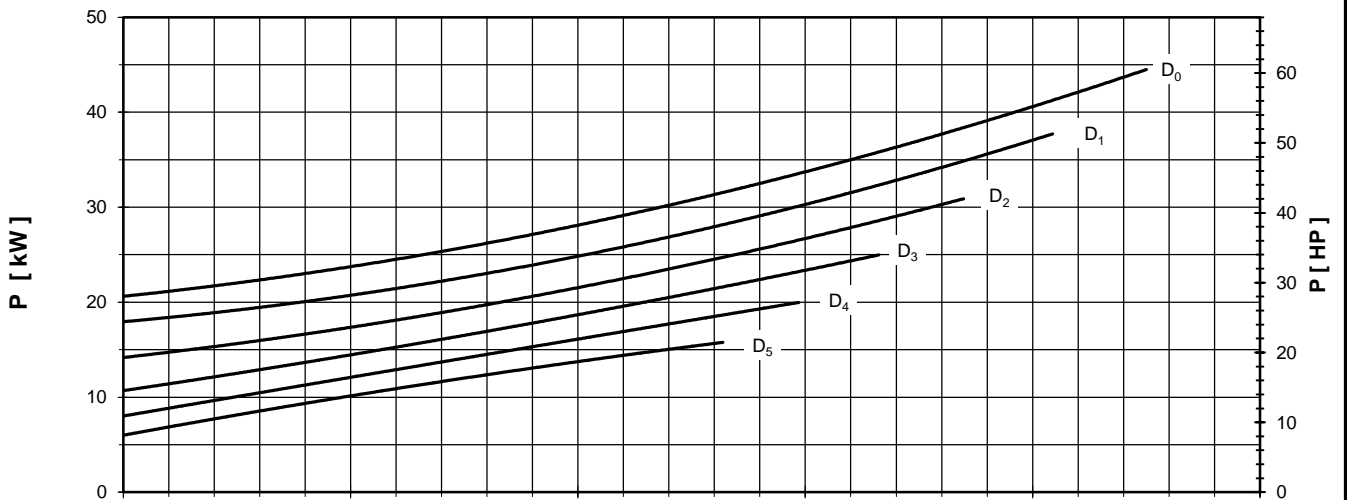
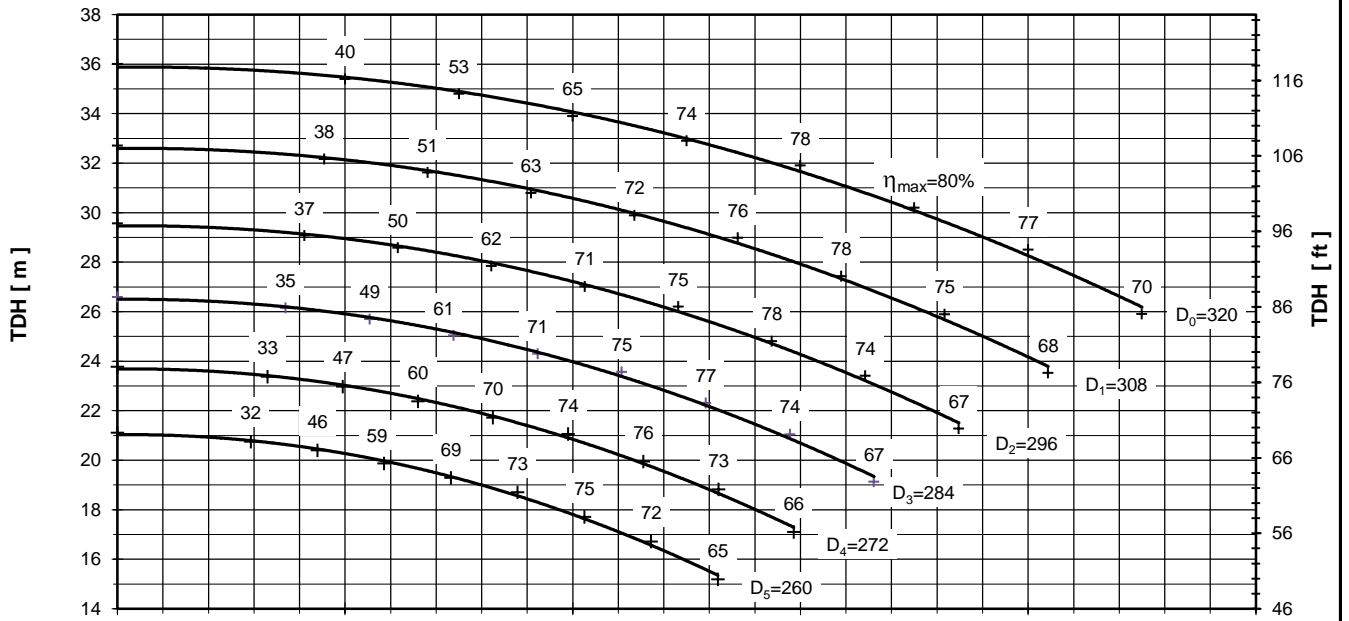

Performance curves are valid for clean cold water-kinematic viscosity 1 [mm²/s], density 1000 [kg/m³]. Methods and tolerances of presented performance curves are in accordance with ISO 9906 - Annex A

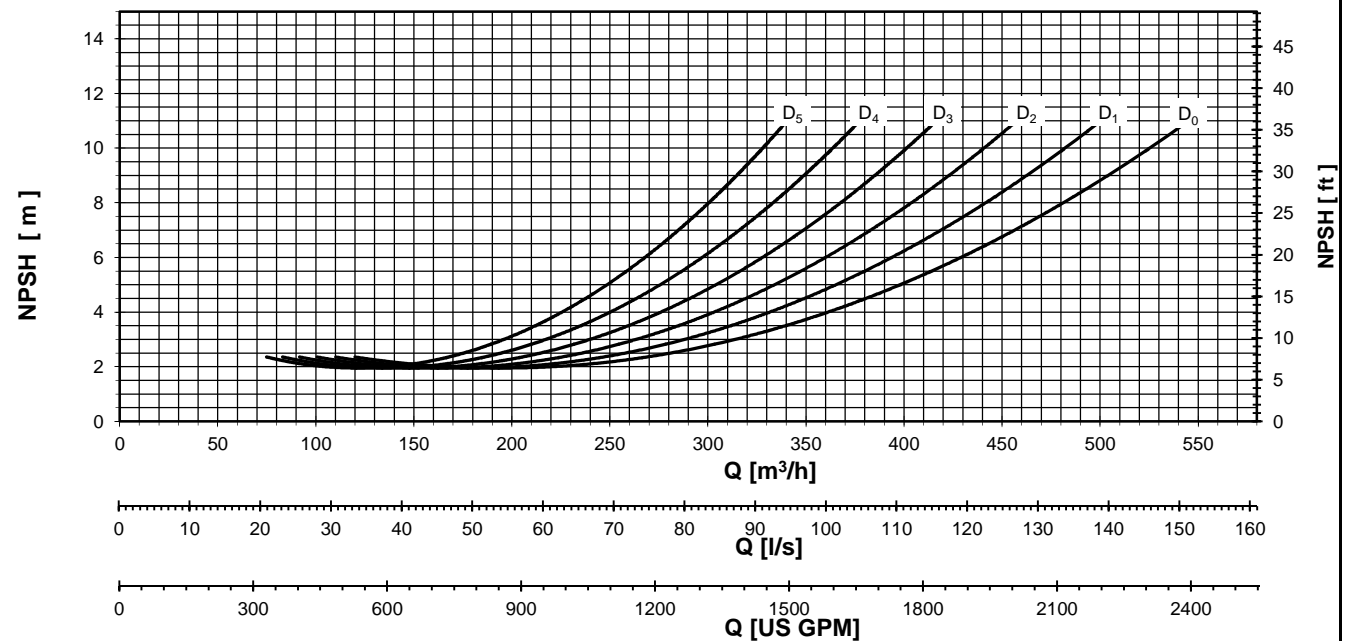
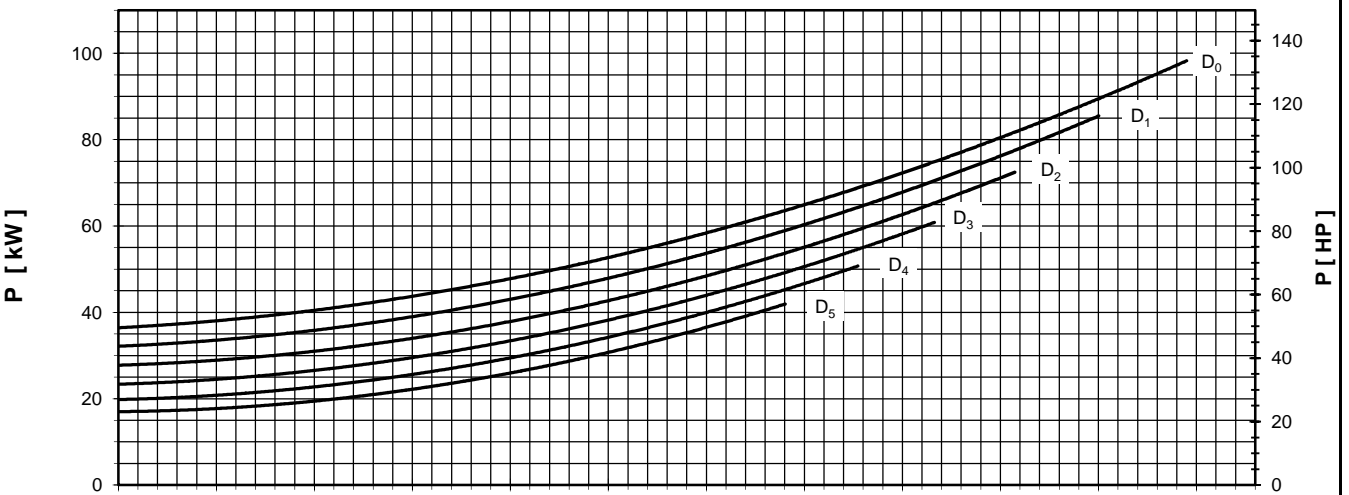
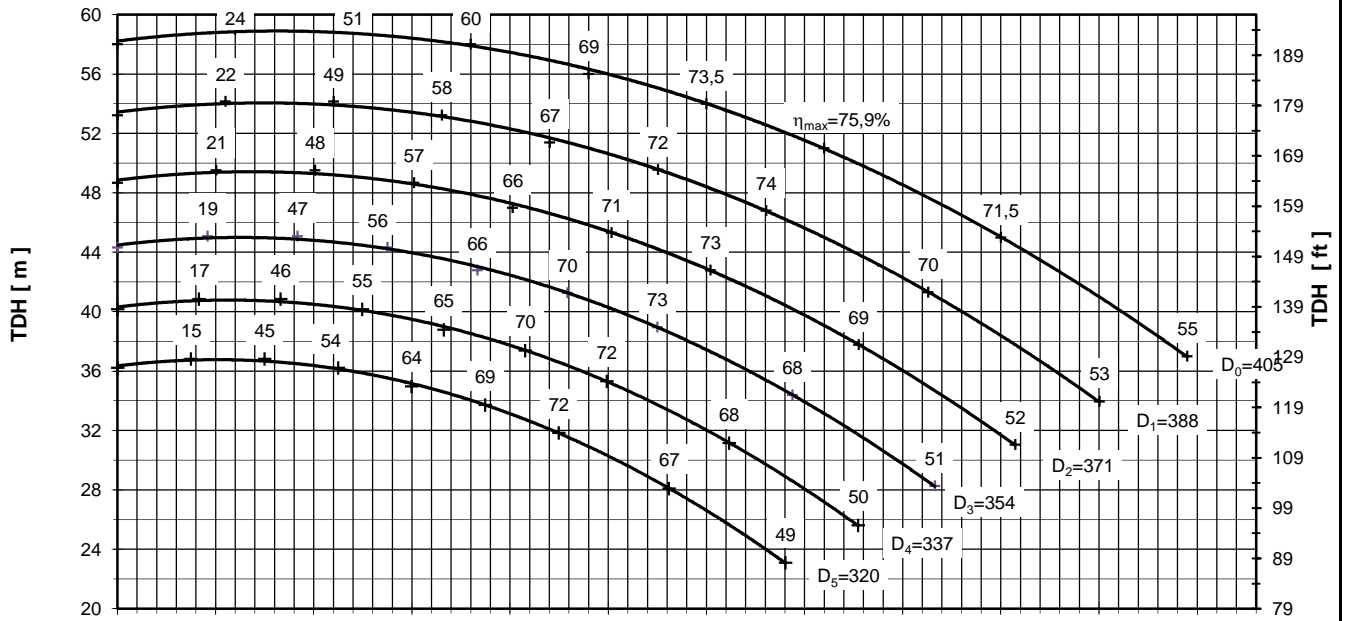

Performance curves are valid for clean cold water-kinematic viscosity 1 [mm²/s], density 1000 [kg/m³]. Methods and tolerances of presented performance curves are in accordance with ISO 9906 - Annex A

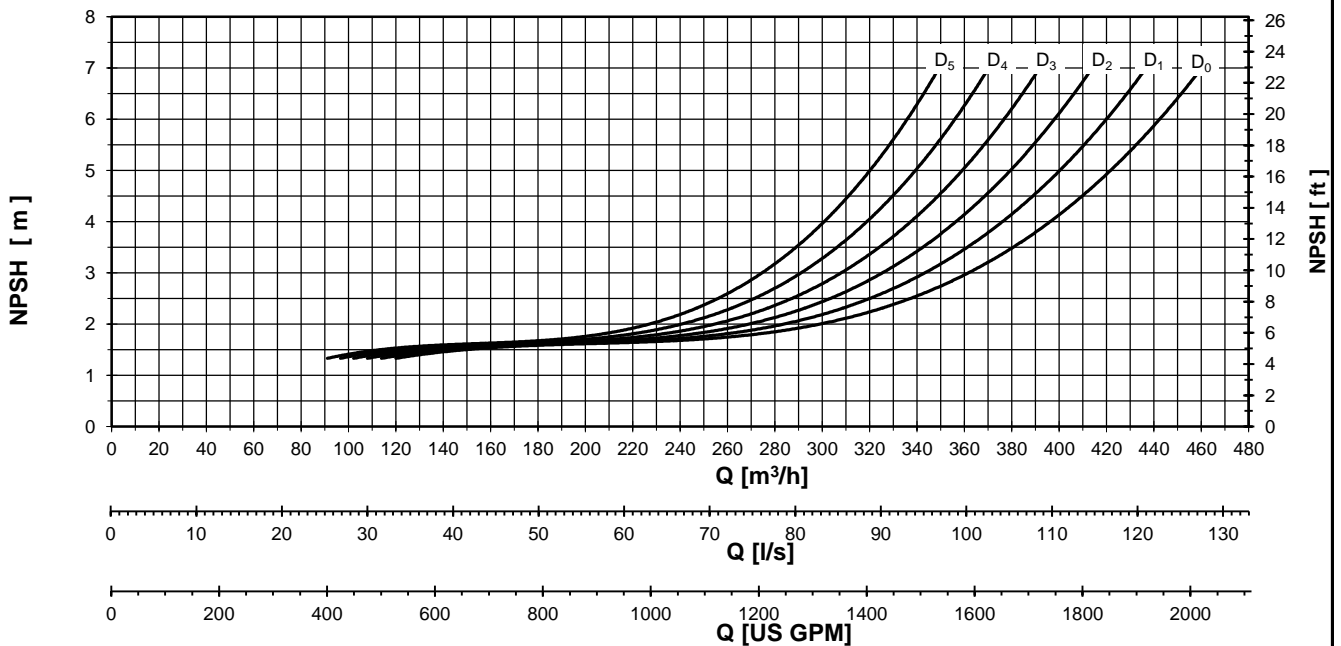
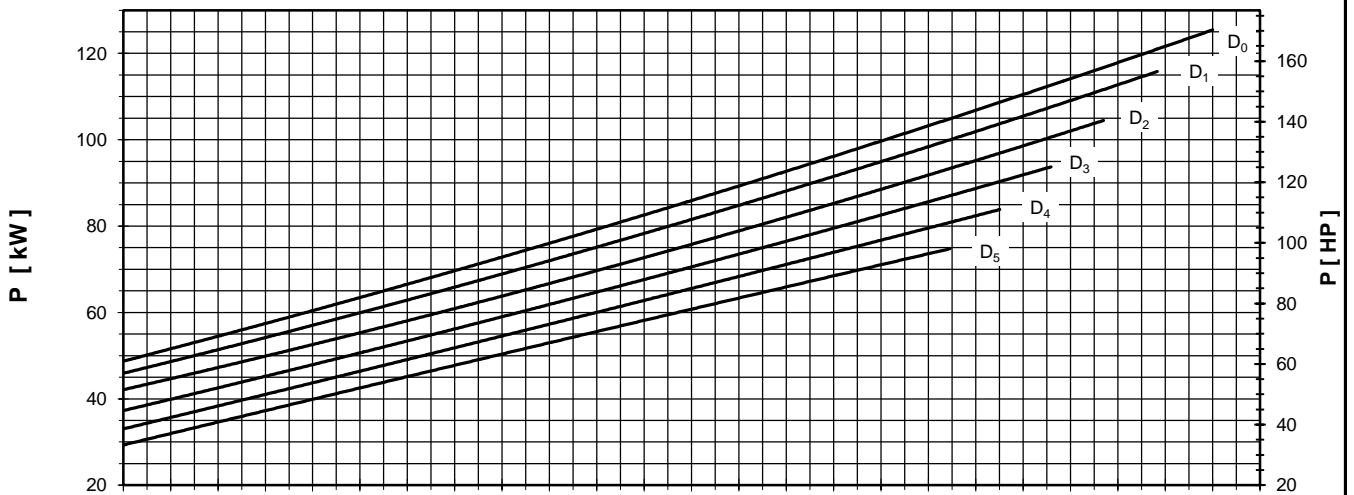
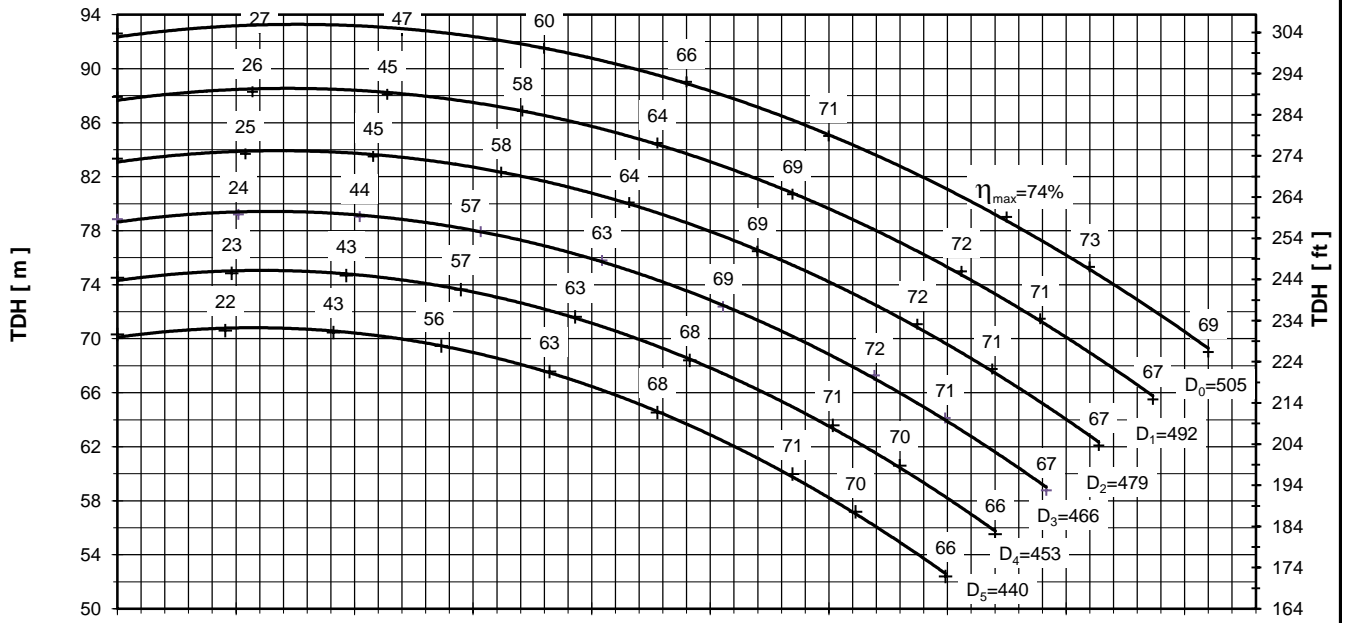

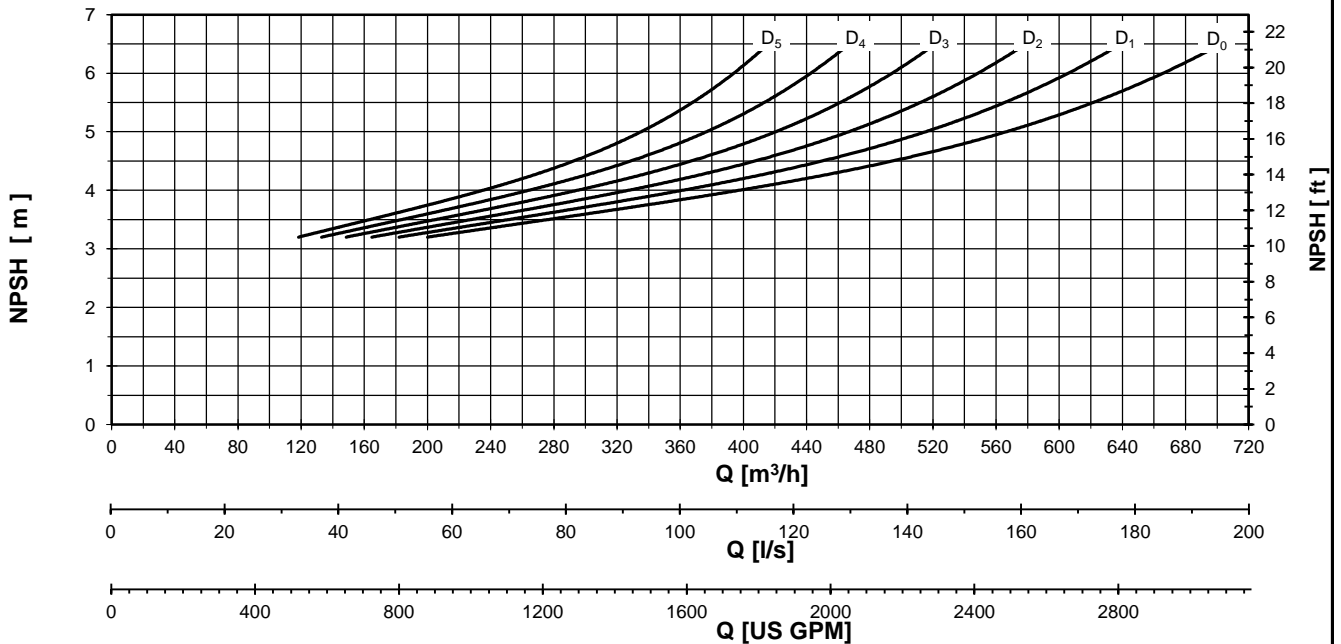
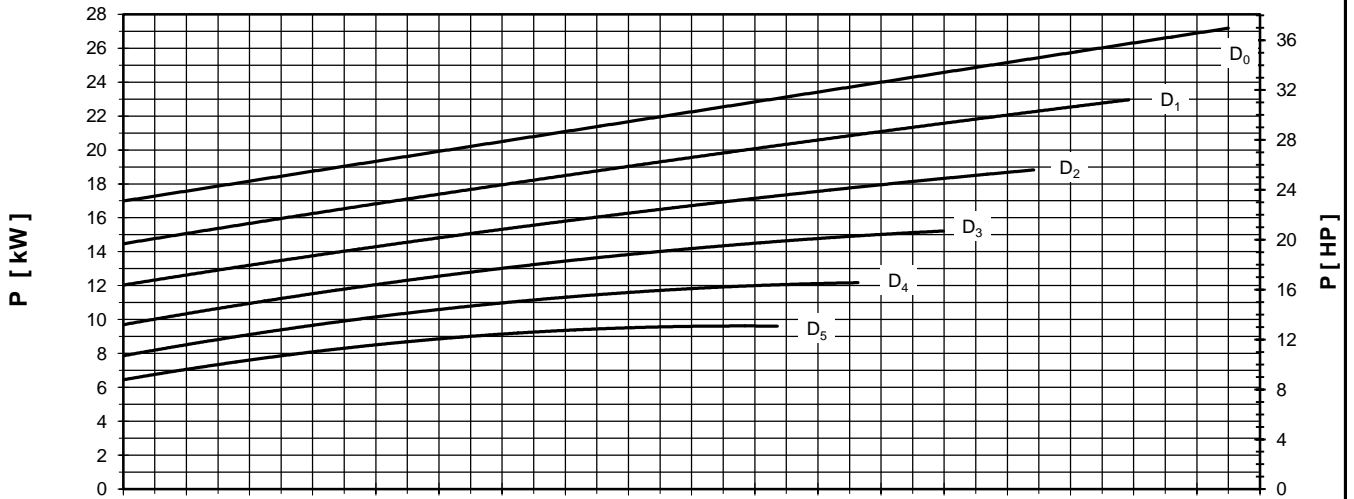
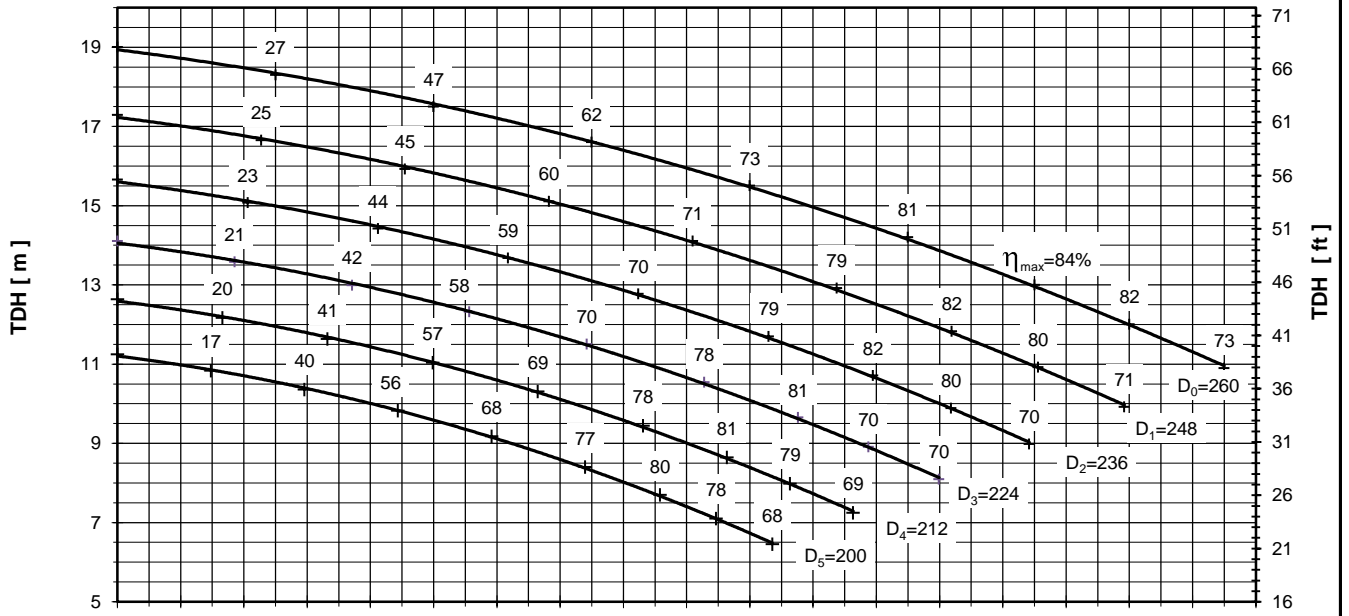

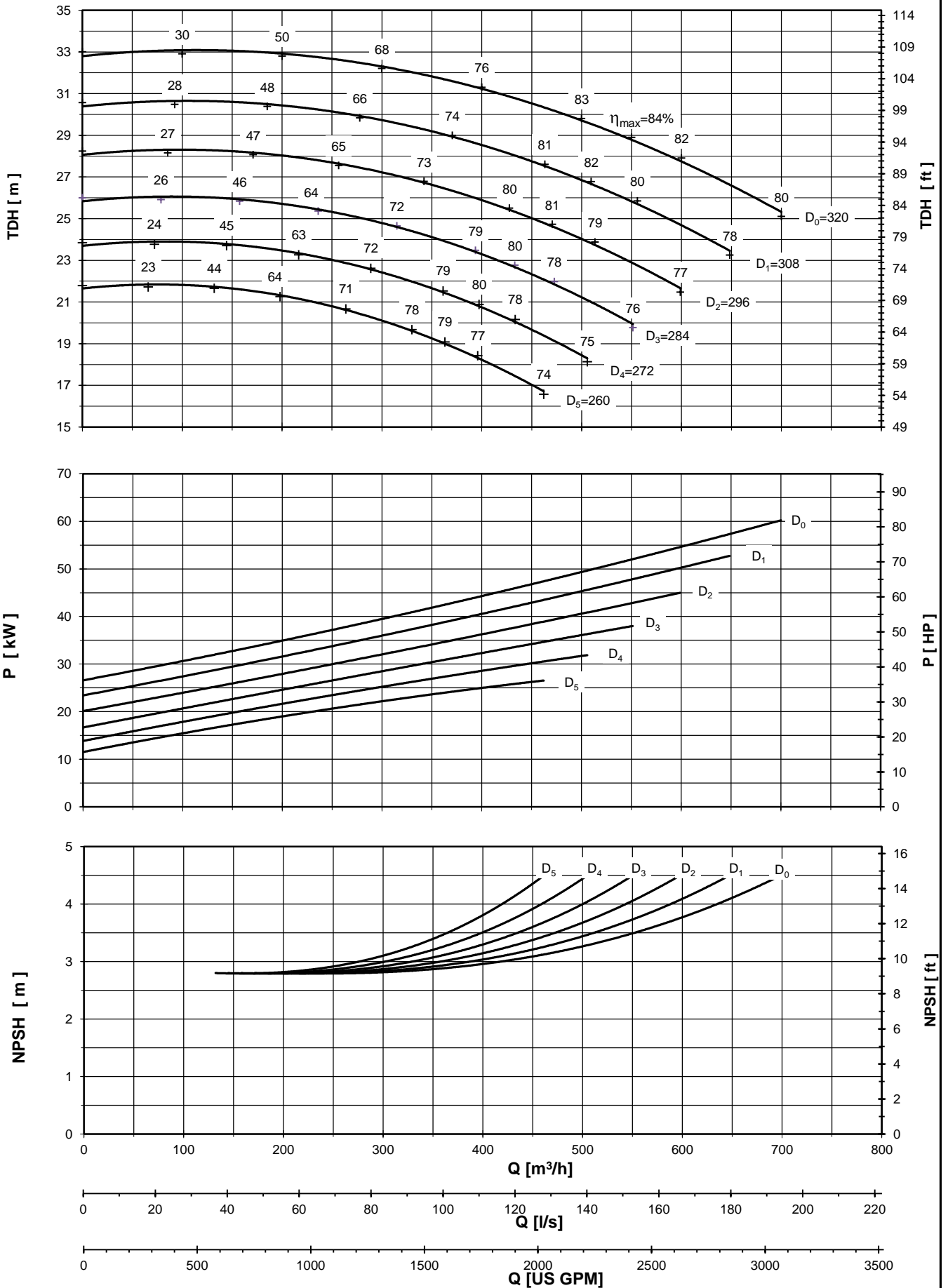

Performance curves are valid for clean cold water-kinematic viscosity 1 [mm²/s], density 1000 [kg/m³]. Methods and tolerances of presented performance curves are in accordance with ISO 9906 - Annex A



PUMP PERFORMANCE CURVES
No. 4HD.0177.03

PUMP TYPE
SCP 200 - 400
1450 [rpm]

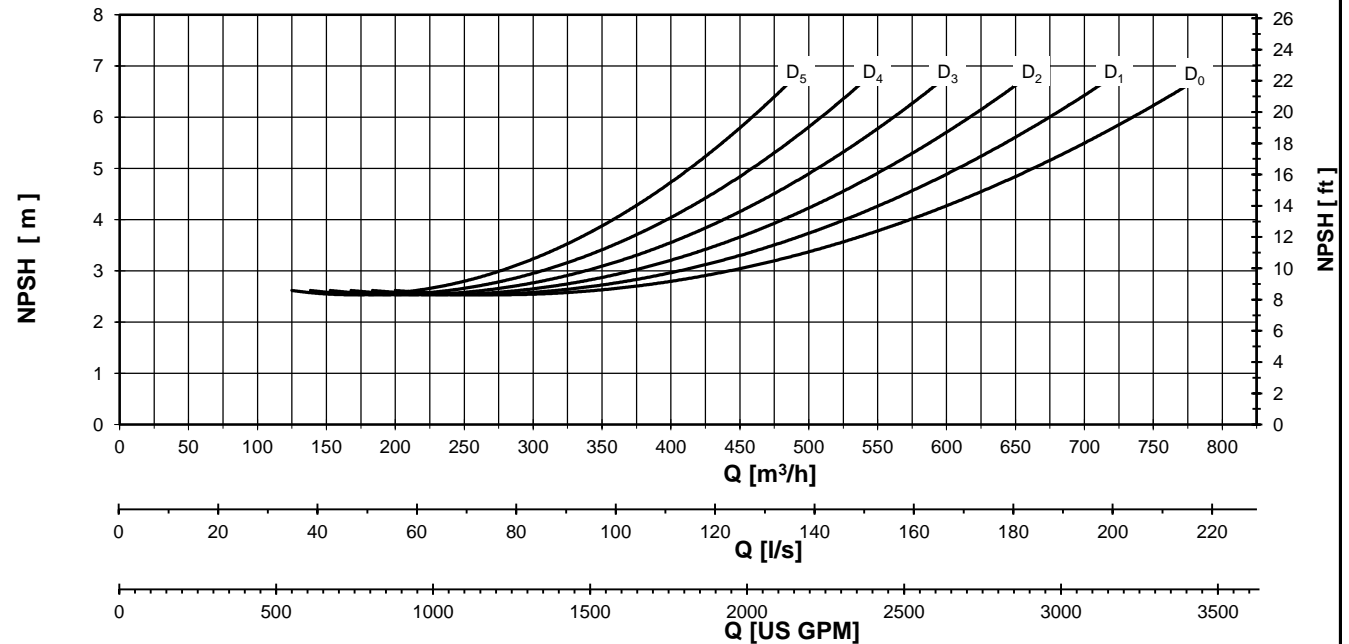
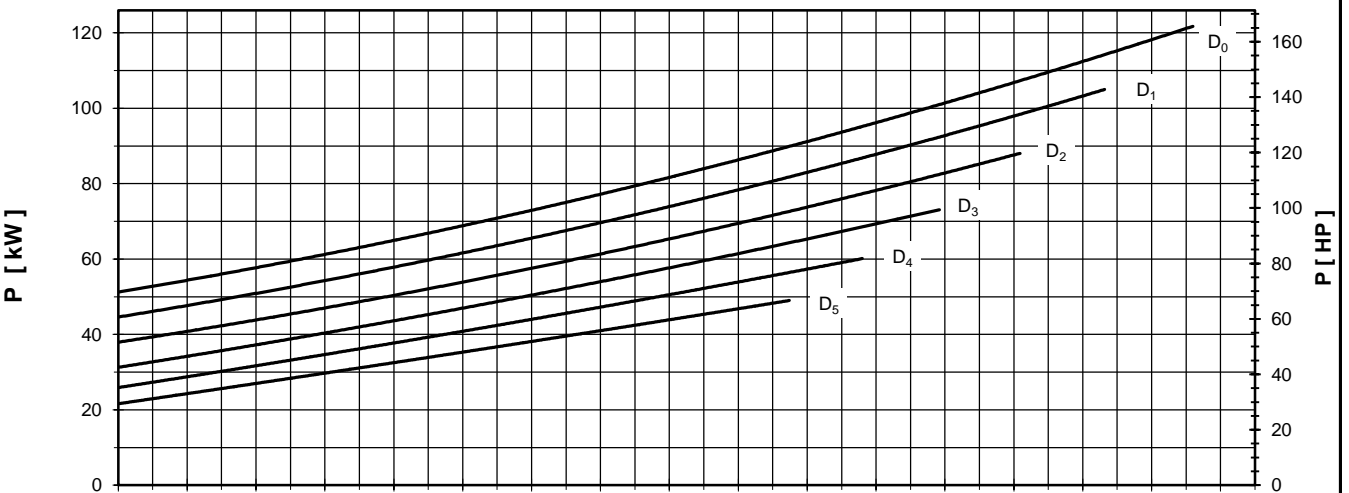
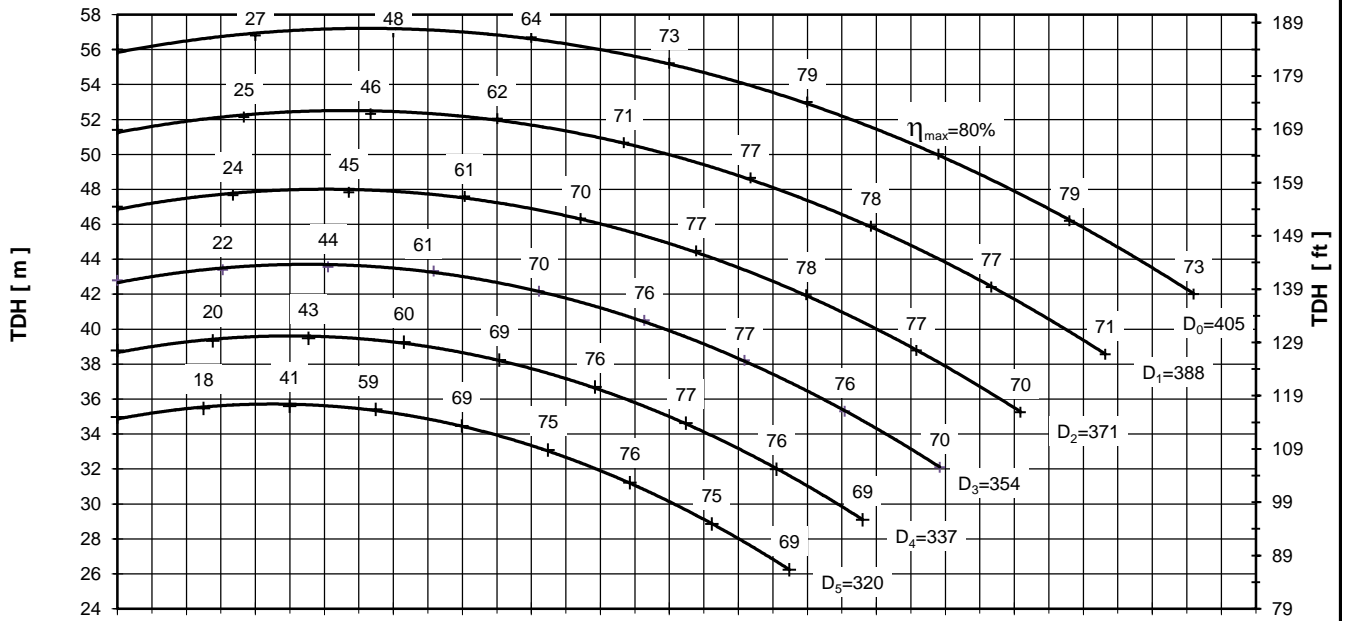

Performance curves are valid for clean cold water-kinematic viscosity 1 [mm²/s], density 1000 [kg/m³]. Methods and tolerances of presented performance curves are in accordance with ISO 9906 - Annex A



PUMP PERFORMANCE CURVES
No. 4HD.0178.03

PUMP TYPE
SCP 200 - 500
1450 [rpm]

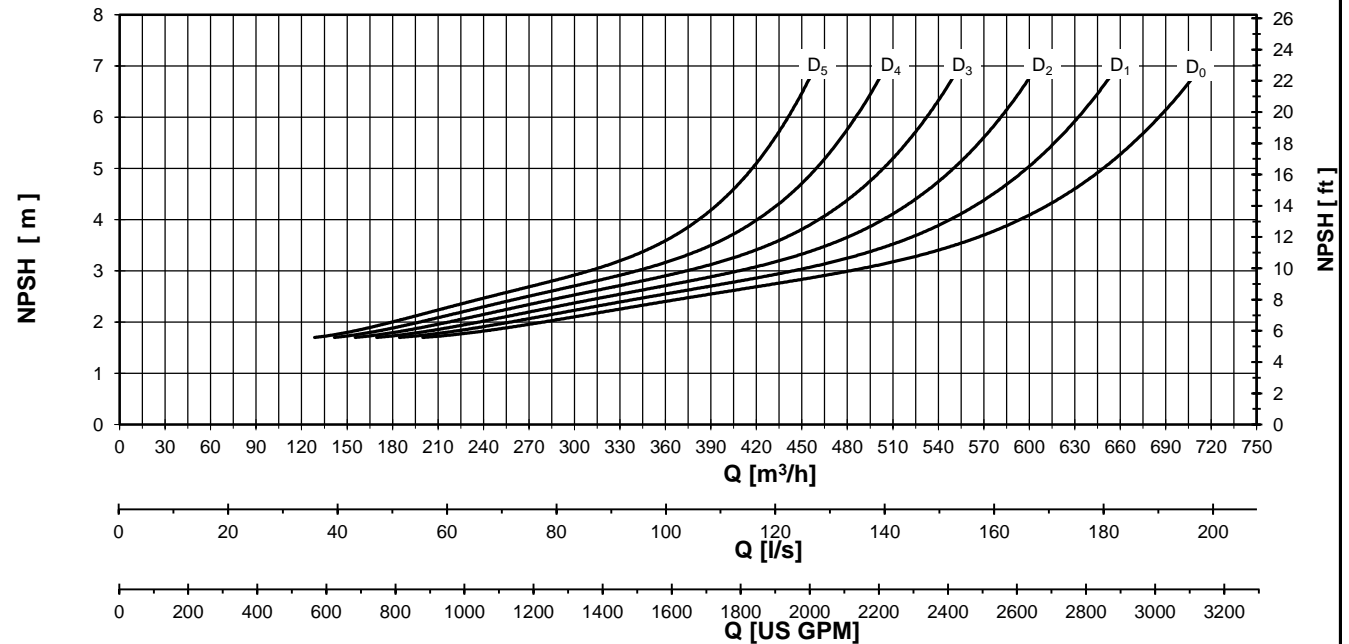
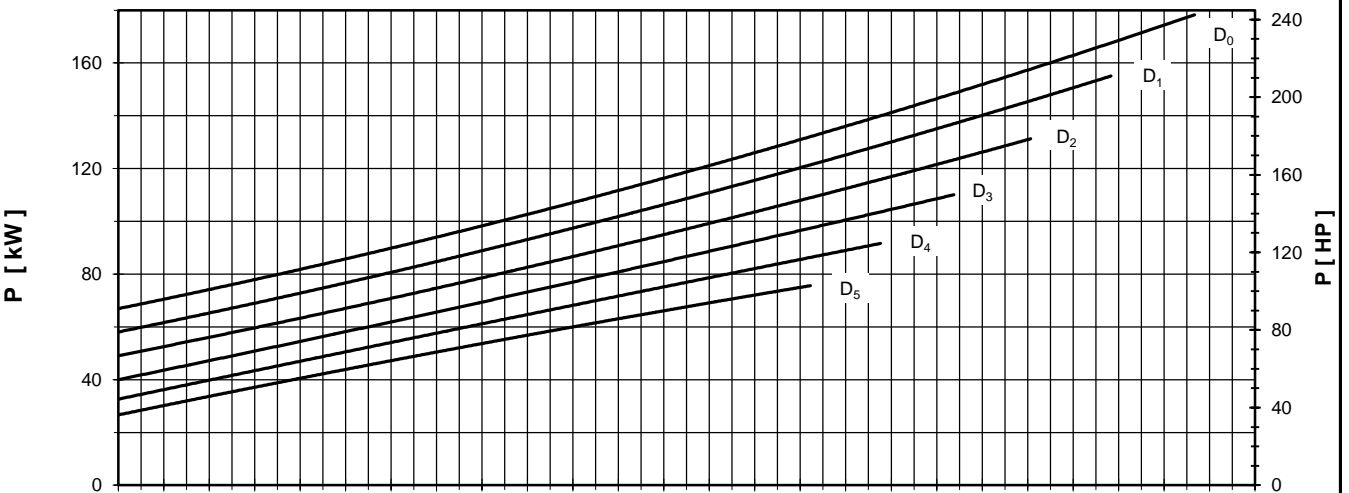
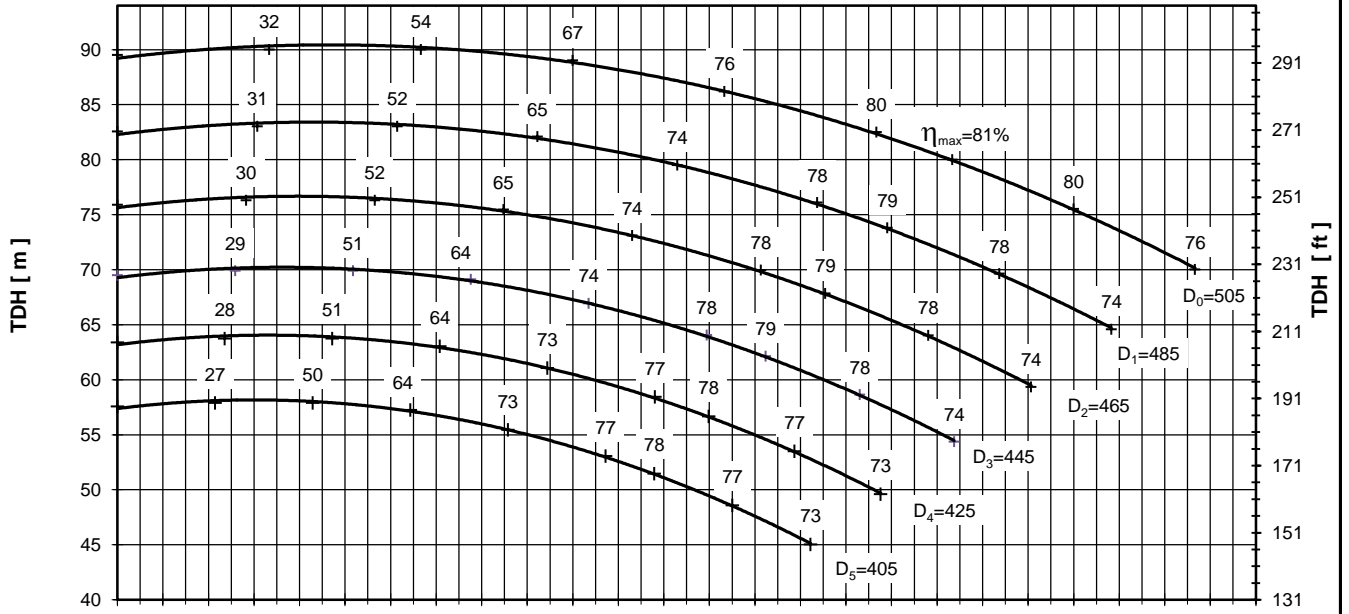

Performance curves are valid for clean cold water-kinematic viscosity 1 [mm²/s], density 1000 [kg/m³]. Methods and tolerances of presented performance curves are in accordance with ISO 9906 - Annex A

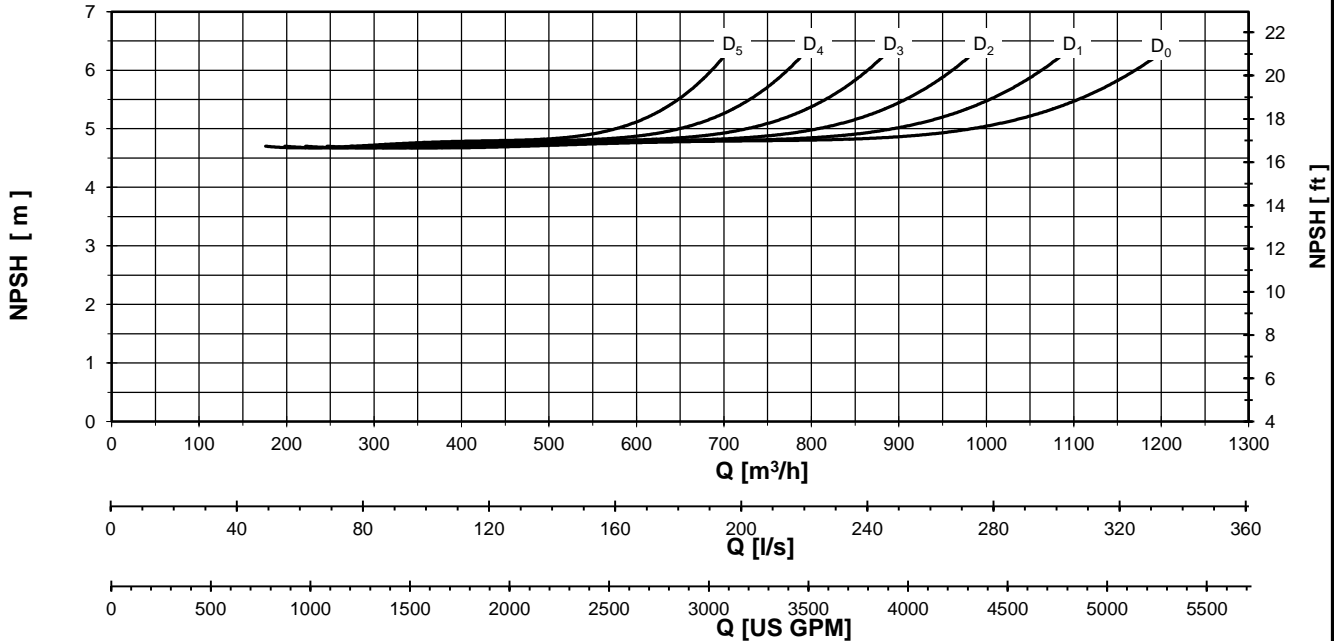
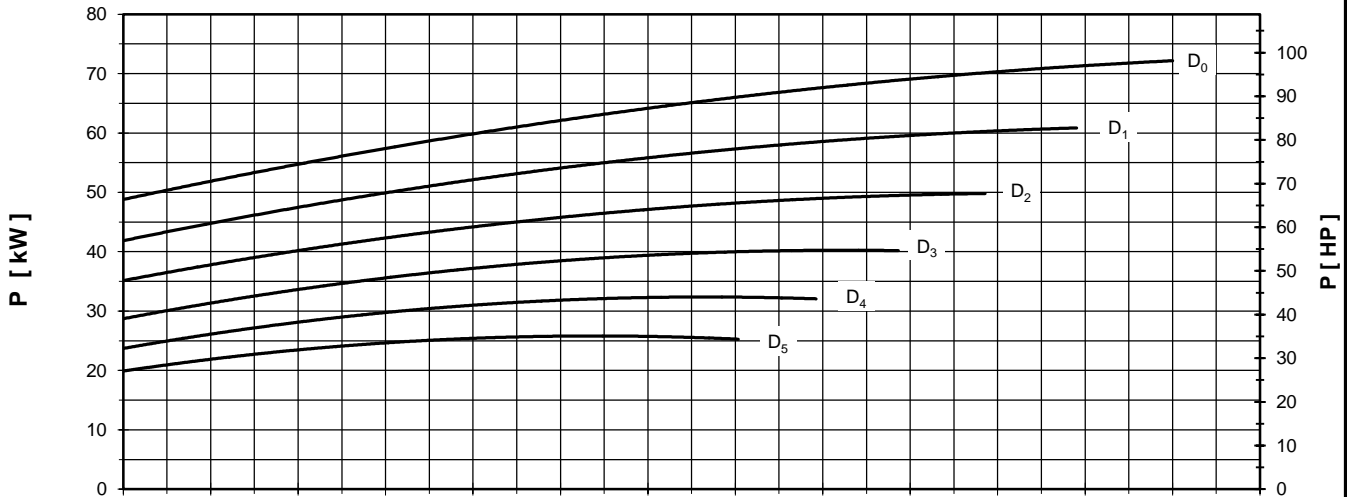
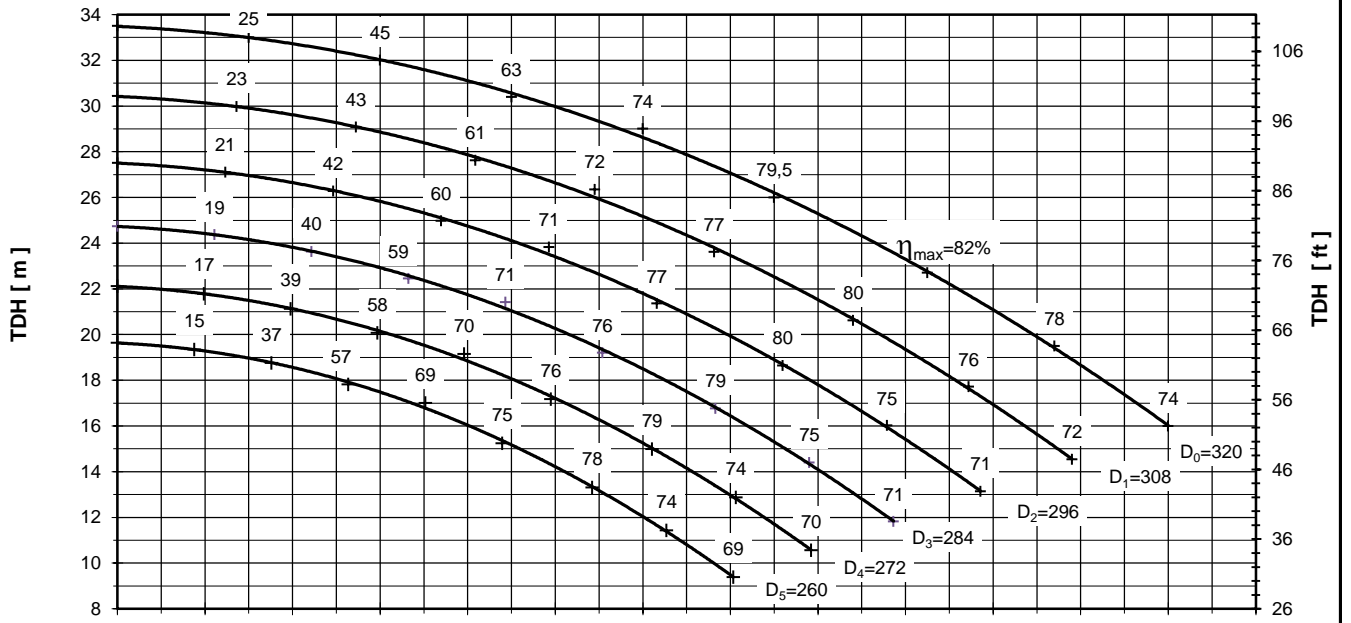



PUMP PERFORMANCE CURVES
No. 4HD.0179.03

PUMP TYPE
SCP 250 - 400
1450 [rpm]

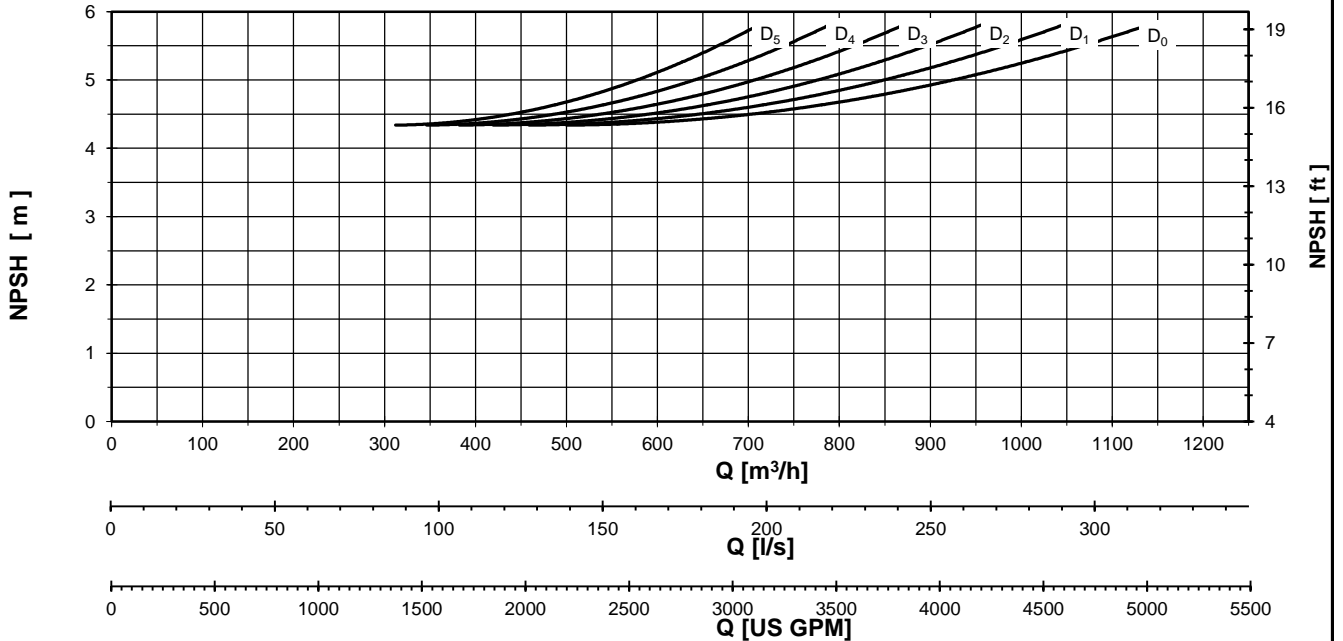
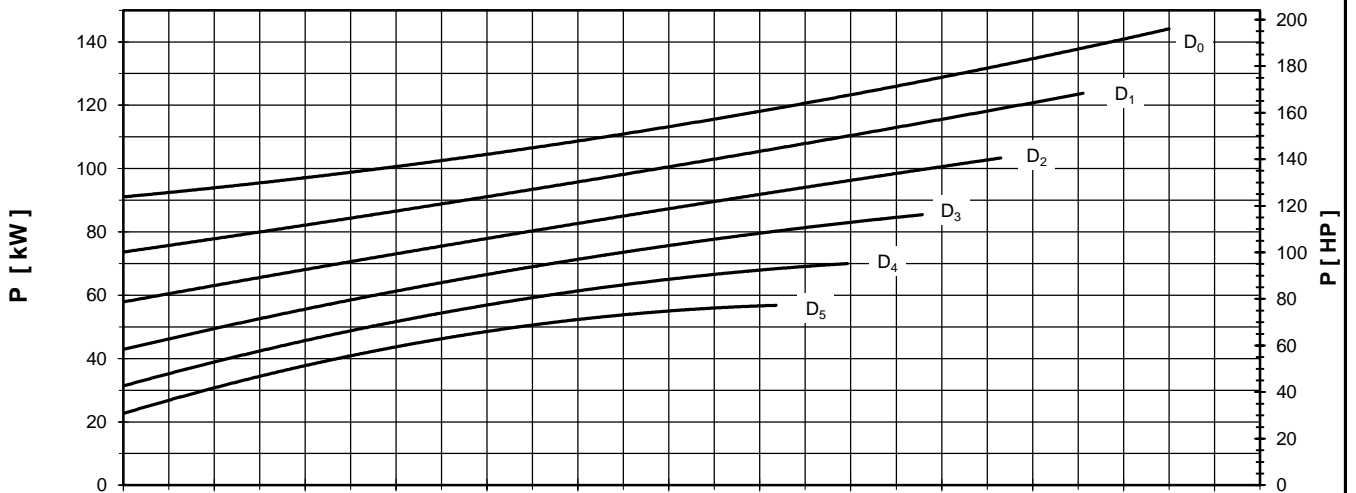
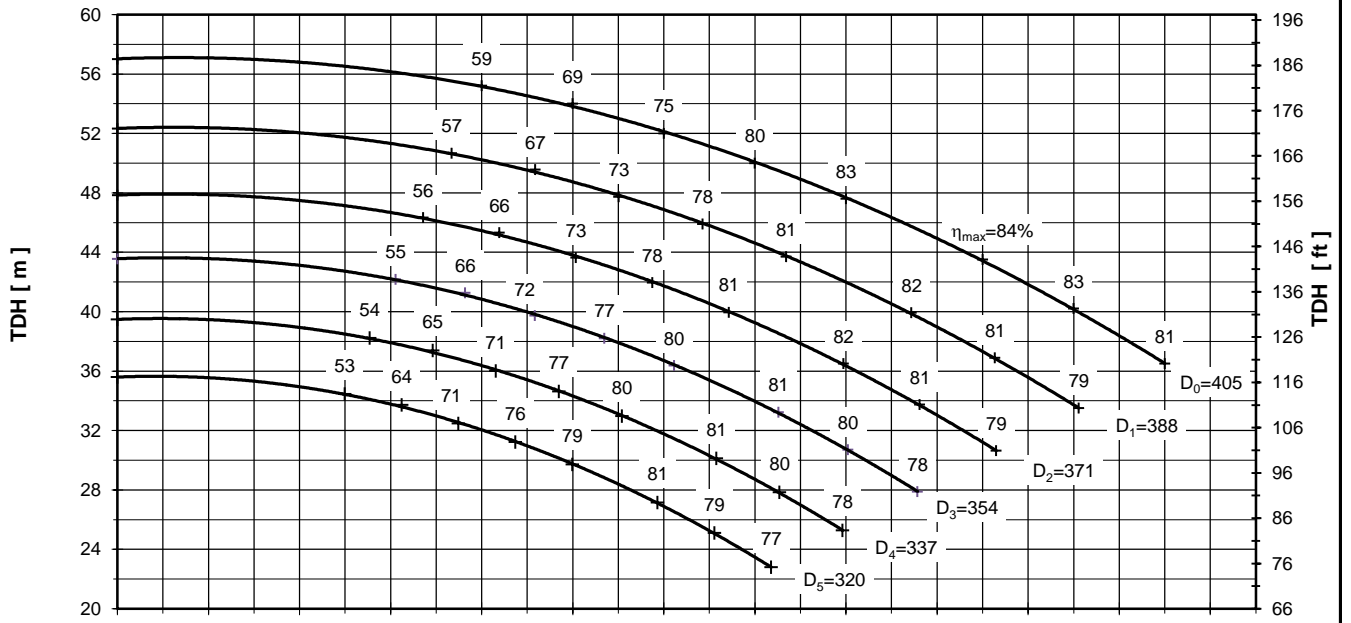

Performance curves are valid for clean cold water-kinematic viscosity 1 [mm²/s], density 1000 [kg/m³]. Methods and tolerances of presented performance curves are in accordance with ISO 9906 - Annex A



PUMP PERFORMANCE CURVES
No. 4HD.0180.03

PUMP TYPE
SCP 250 - 500
1450 [rpm]

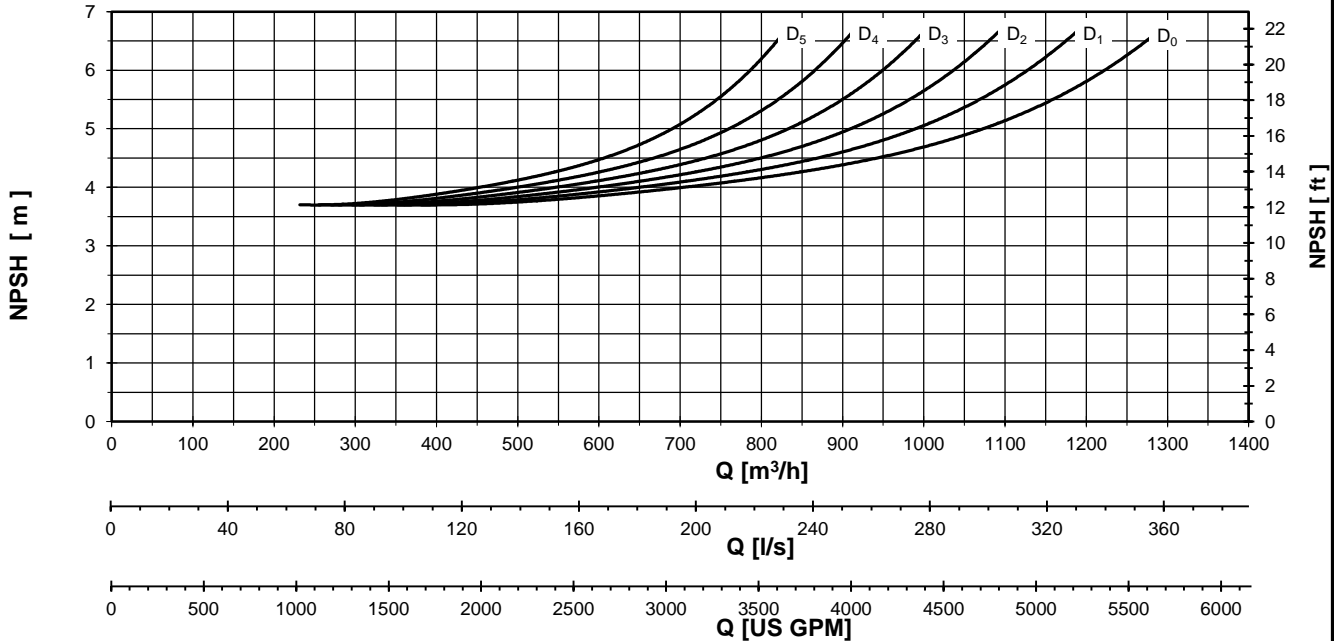
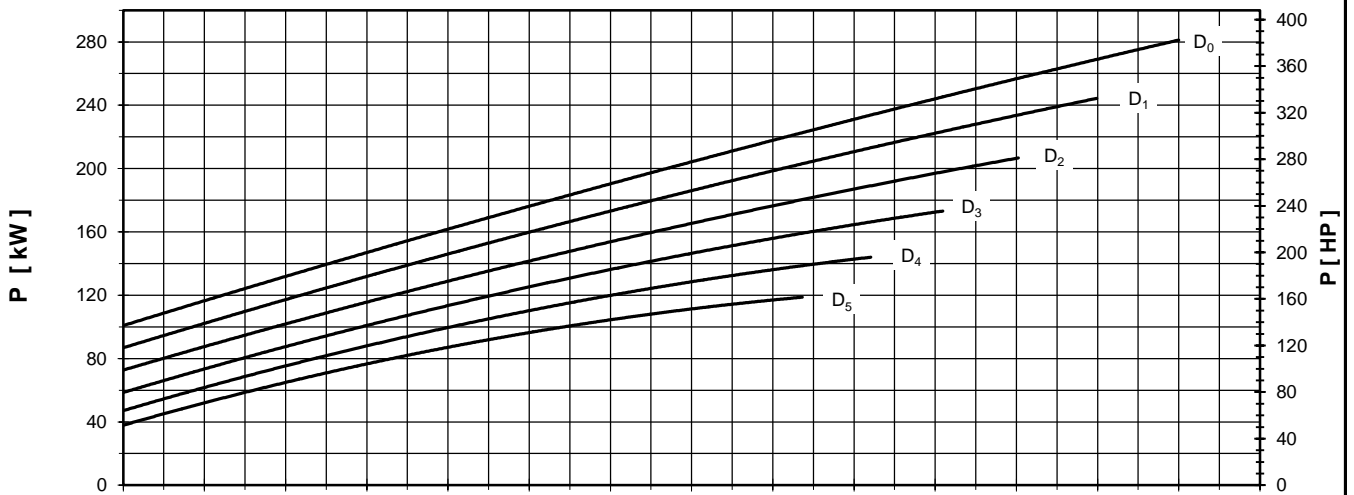
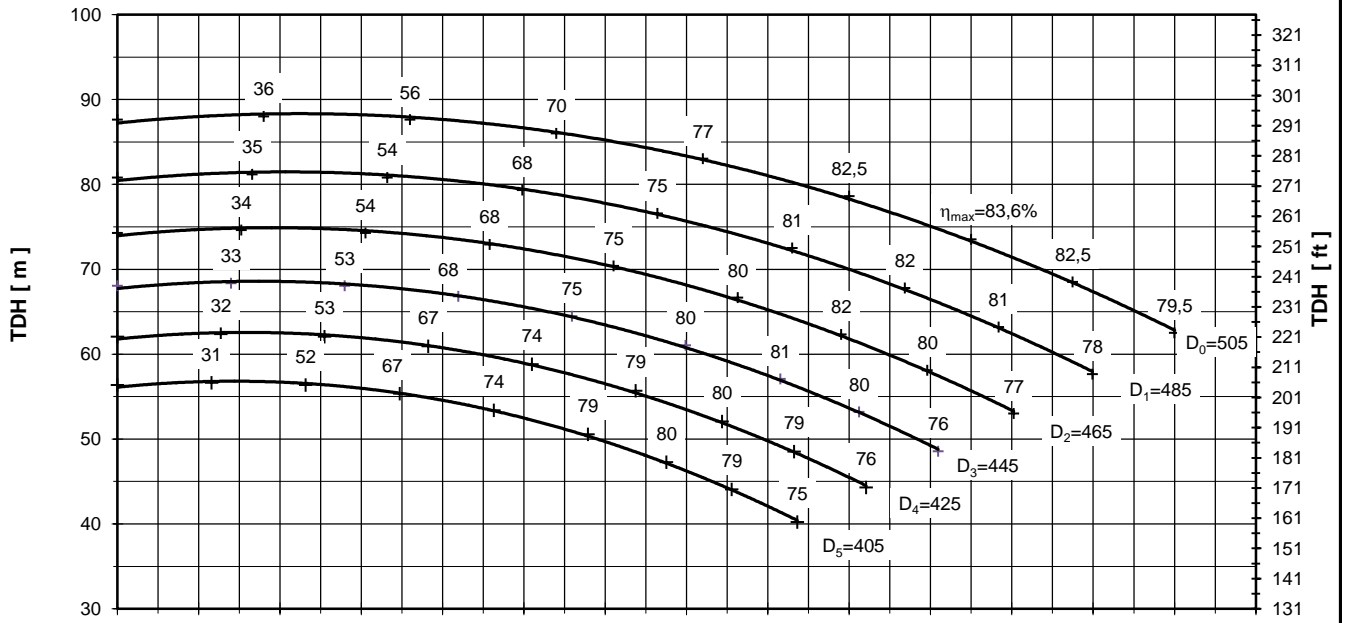

Performance curves are valid for clean cold water-kinematic viscosity 1 [mm²/s], density 1000 [kg/m³]. Methods and tolerances of presented performance curves are in accordance with ISO 9906 - Annex A

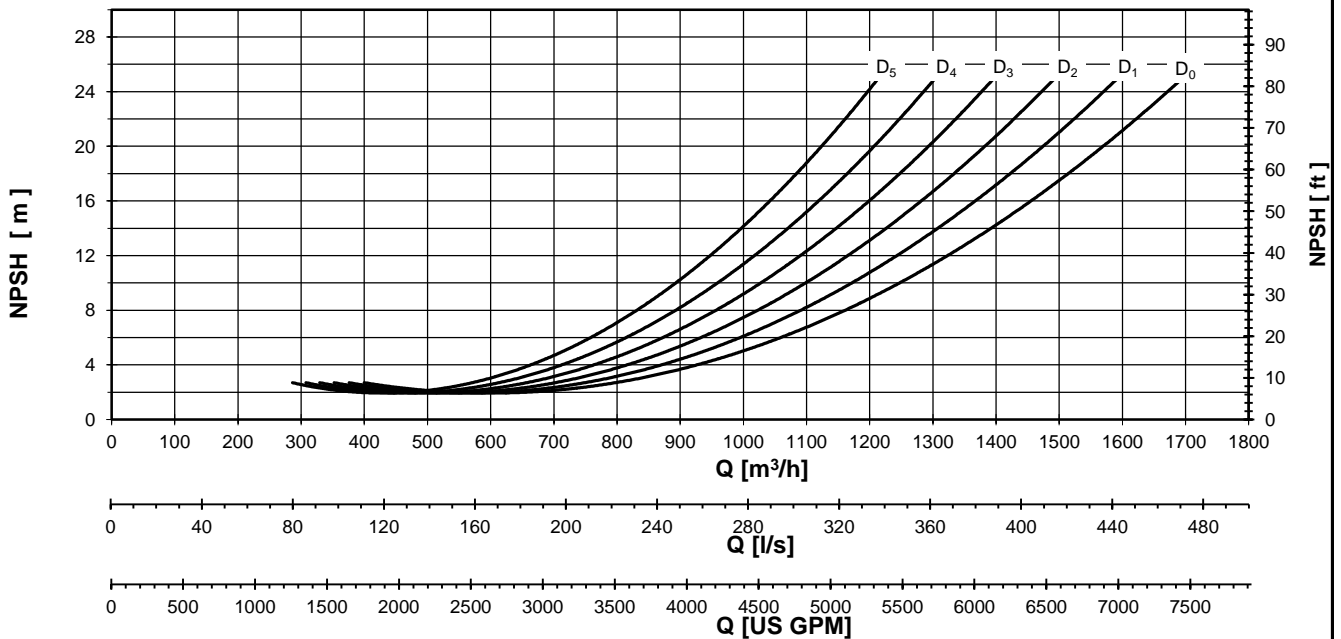
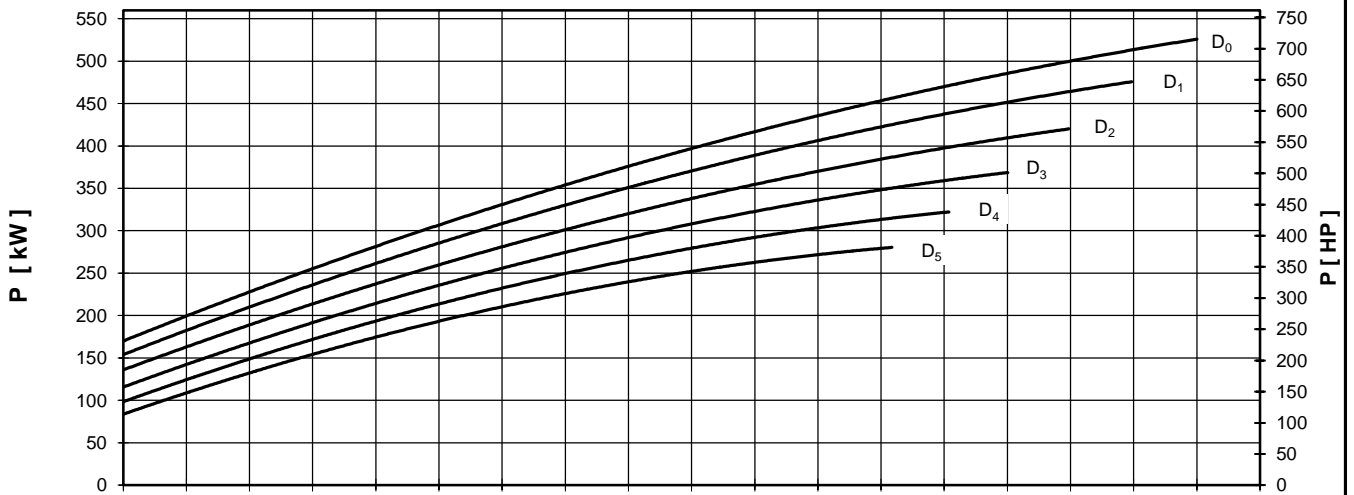
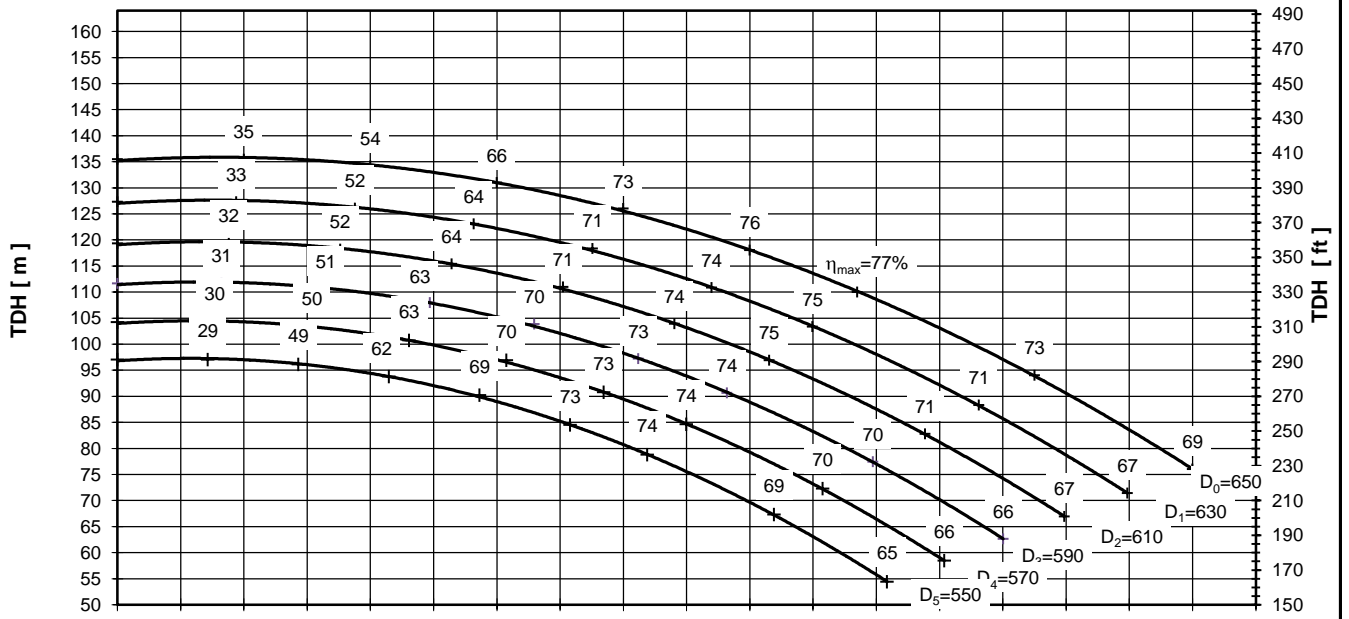

Performance curves are valid for clean cold water-kinematic viscosity 1 [mm²/s], density 1000 [kg/m³]. Methods and tolerances of presented performance curves are in accordance with ISO 9906 - Annex A



PUMP PERFORMANCE CURVES
No. 4HD.0184.03

PUMP TYPE
SCP 250 - 710
1450 [rpm]

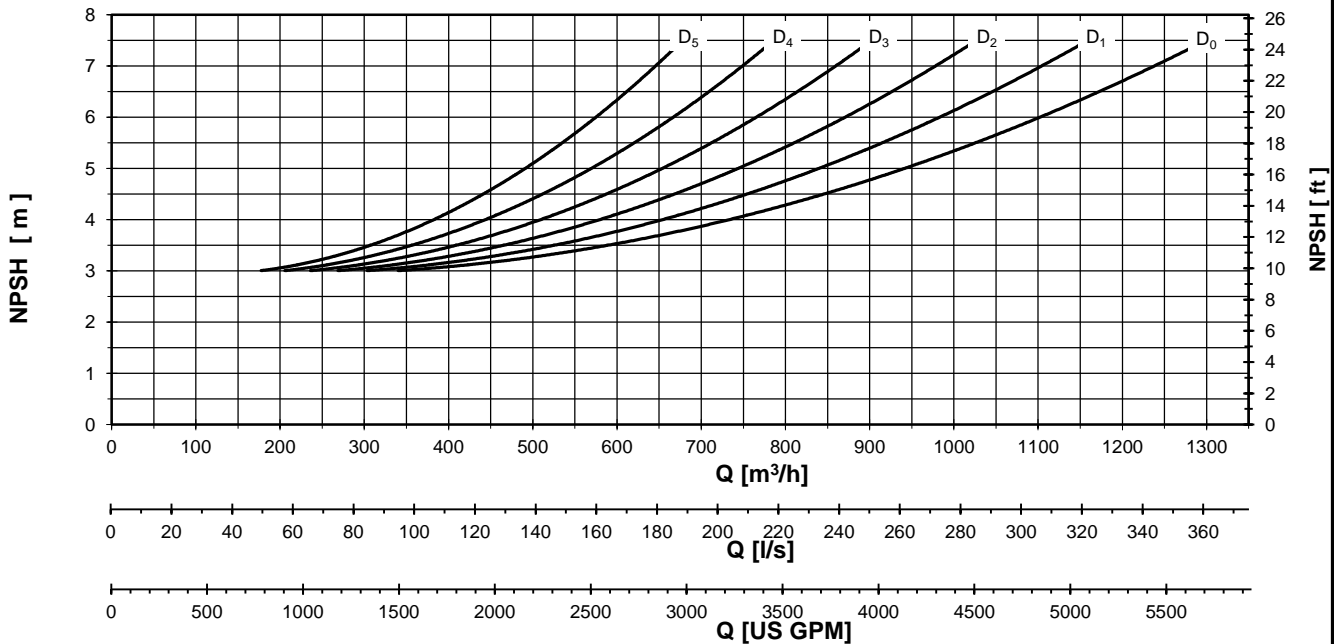
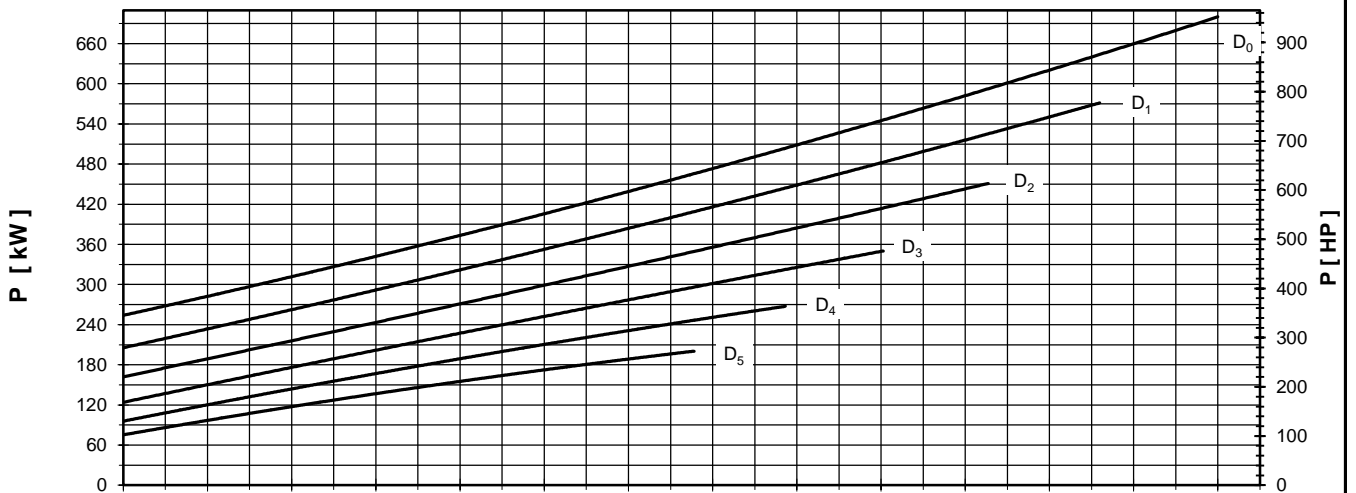
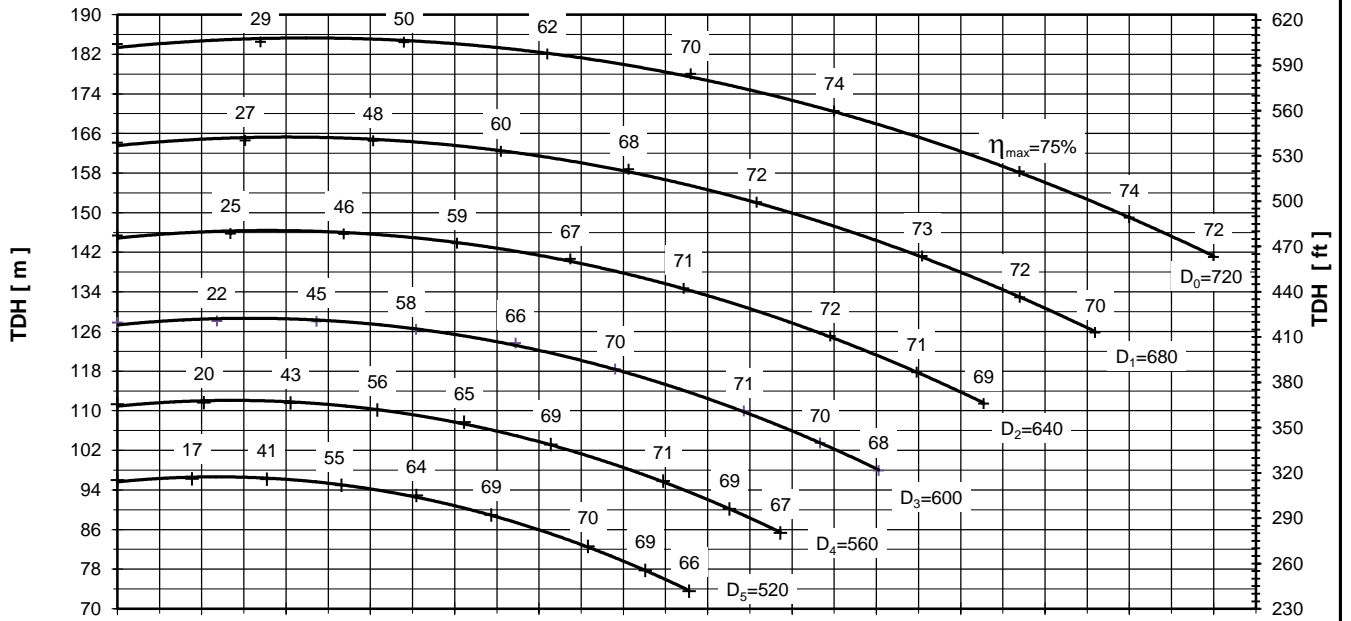

Performance curves are valid for clean cold water-kinematic viscosity 1 [mm²/s], density 1000 [kg/m³]. Methods and tolerances of presented performance curves are in accordance with ISO 9906 - Annex A



PUMP PERFORMANCE CURVES
No. 4HD.0185.03

PUMP TYPE
SCP 300 - 400
1450 [rpm]

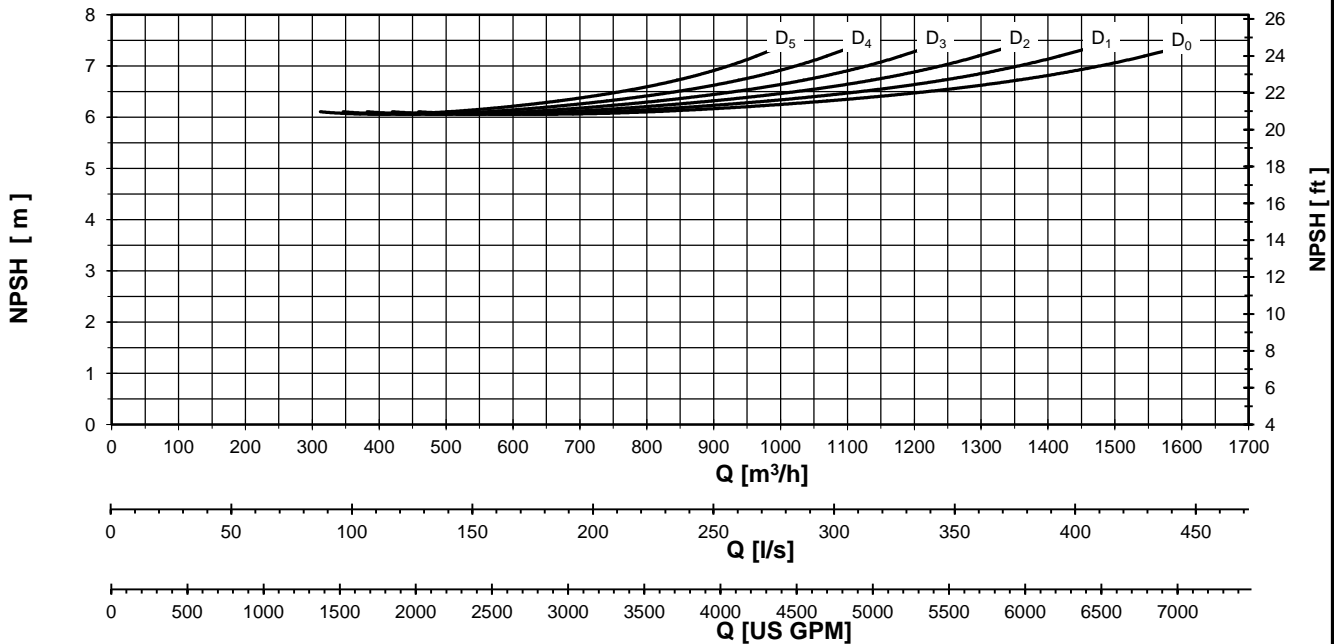
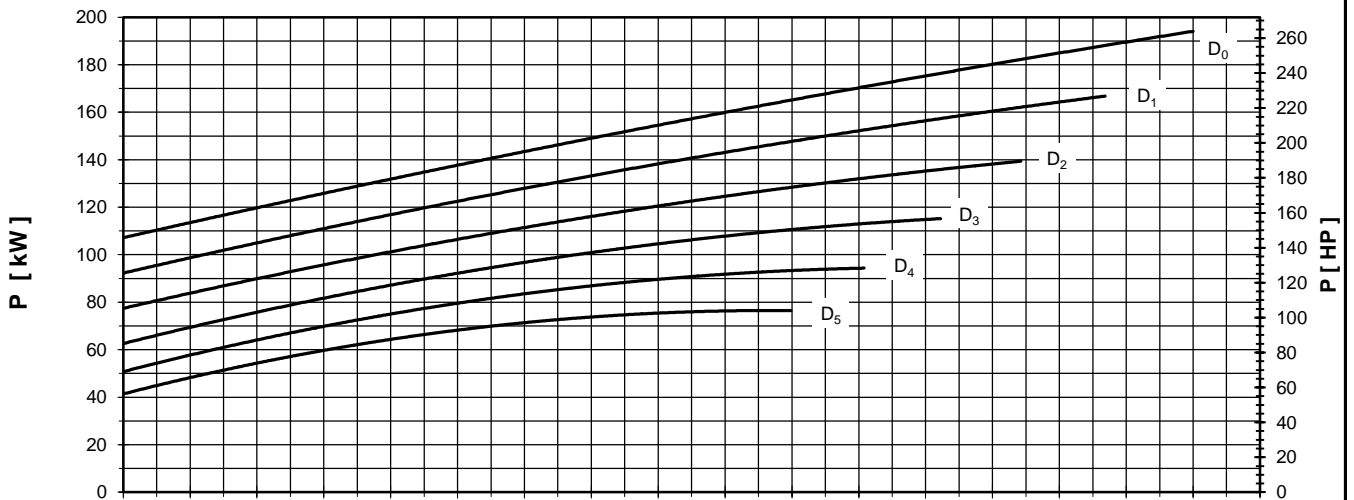
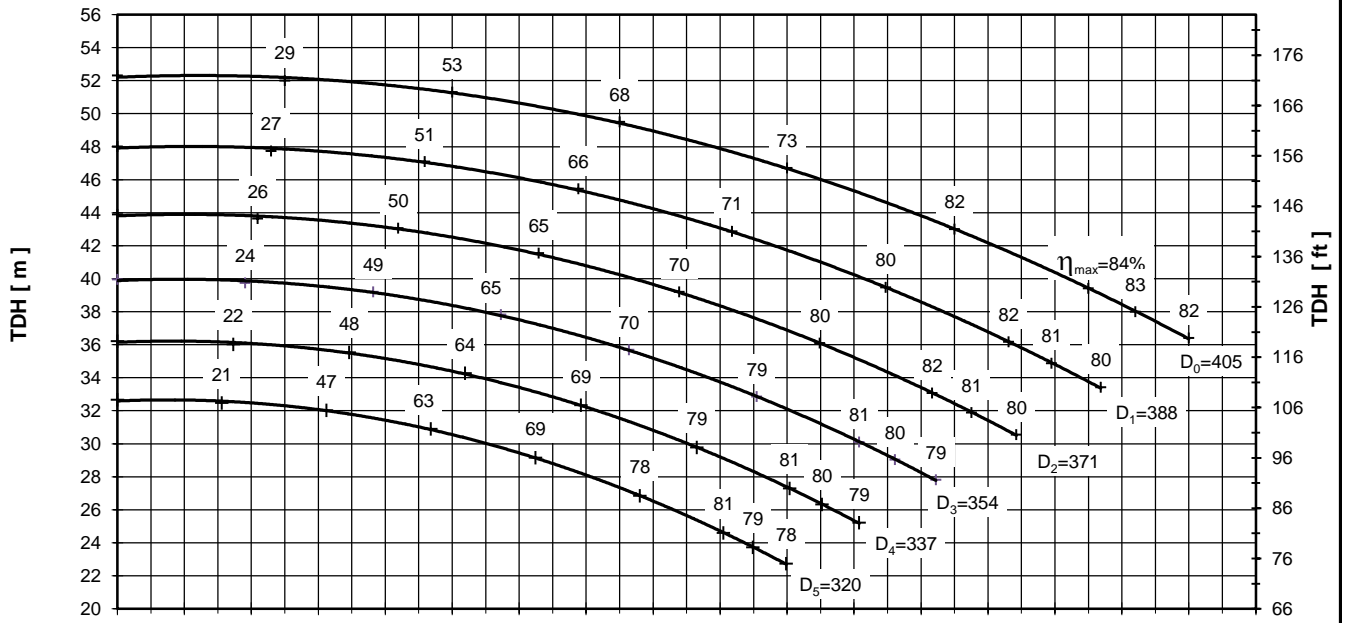

Performance curves are valid for clean cold water-kinematic viscosity 1 [mm²/s], density 1000 [kg/m³]. Methods and tolerances of presented performance curves are in accordance with ISO 9906 - Annex A

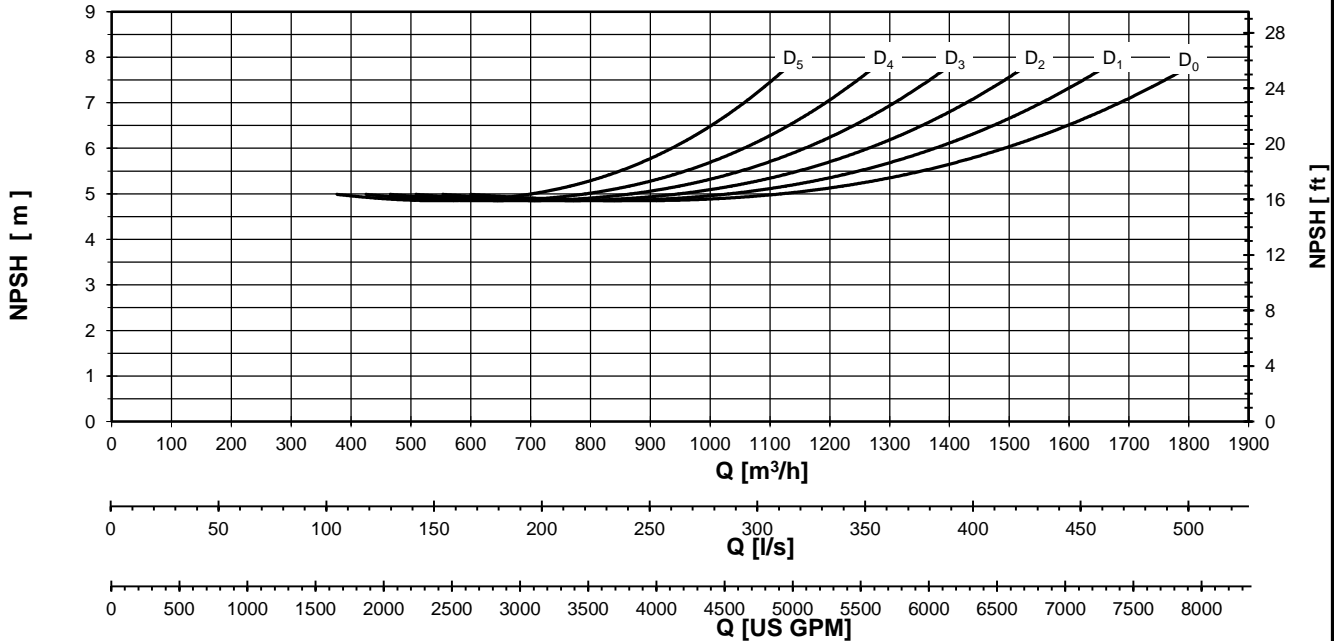
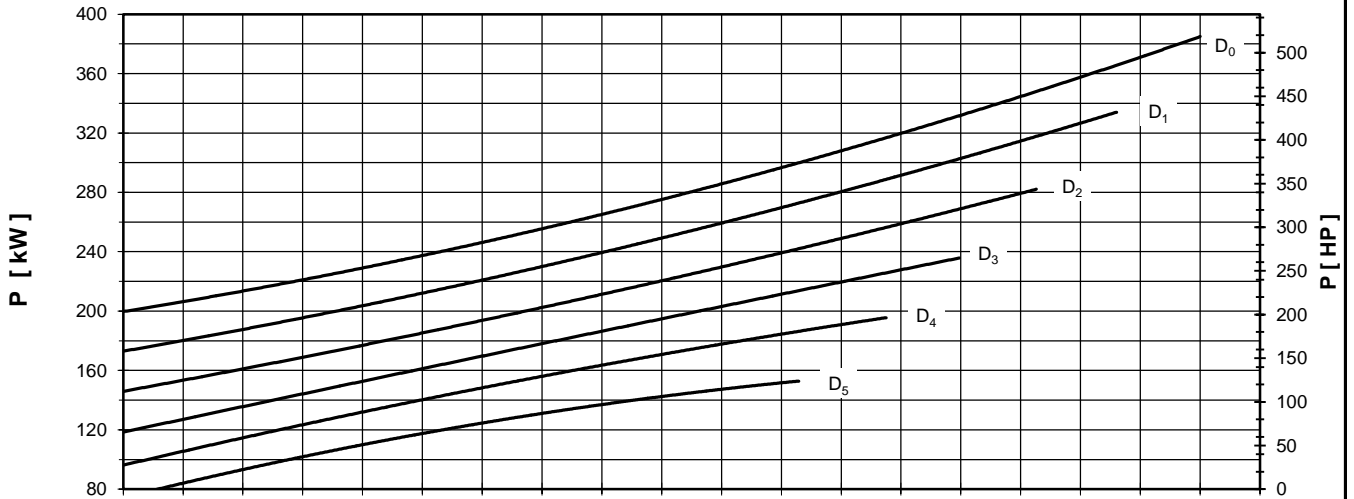
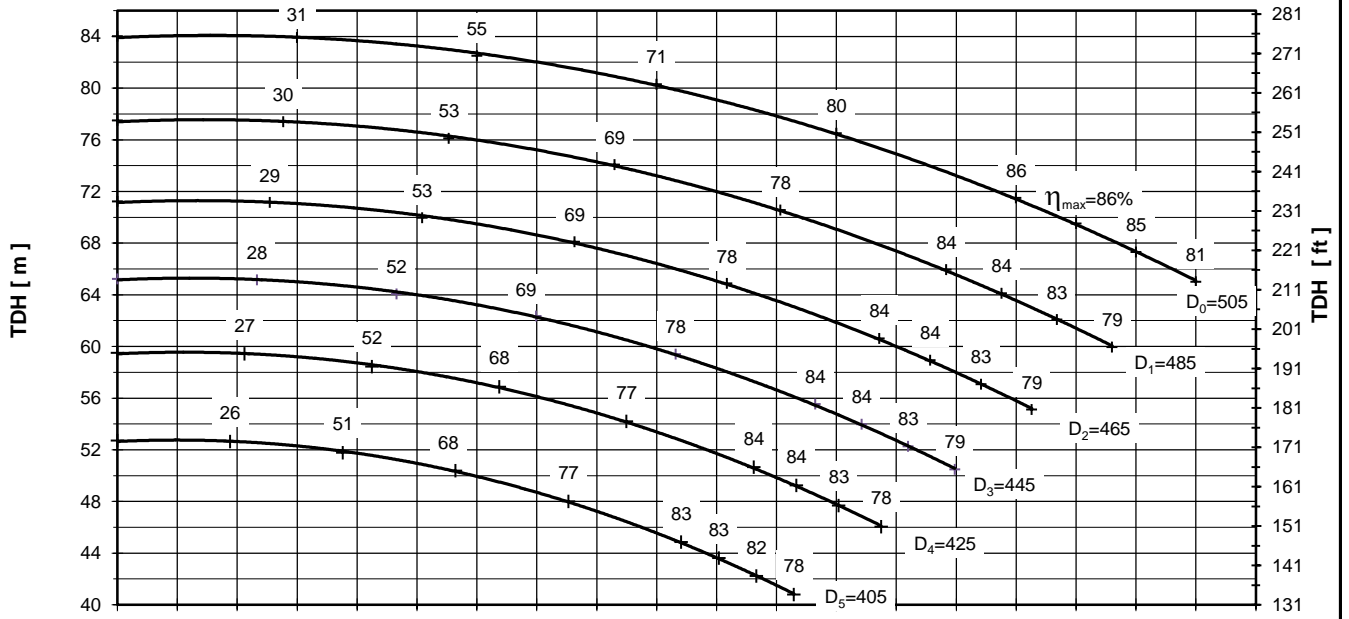

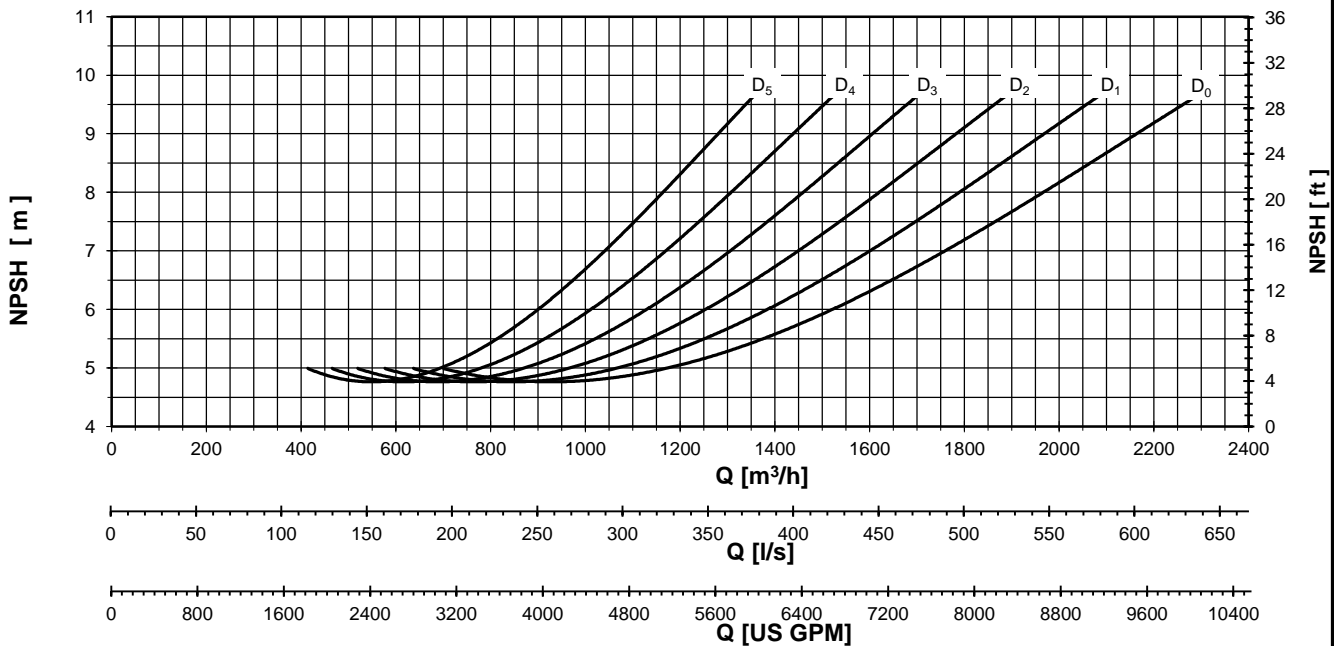
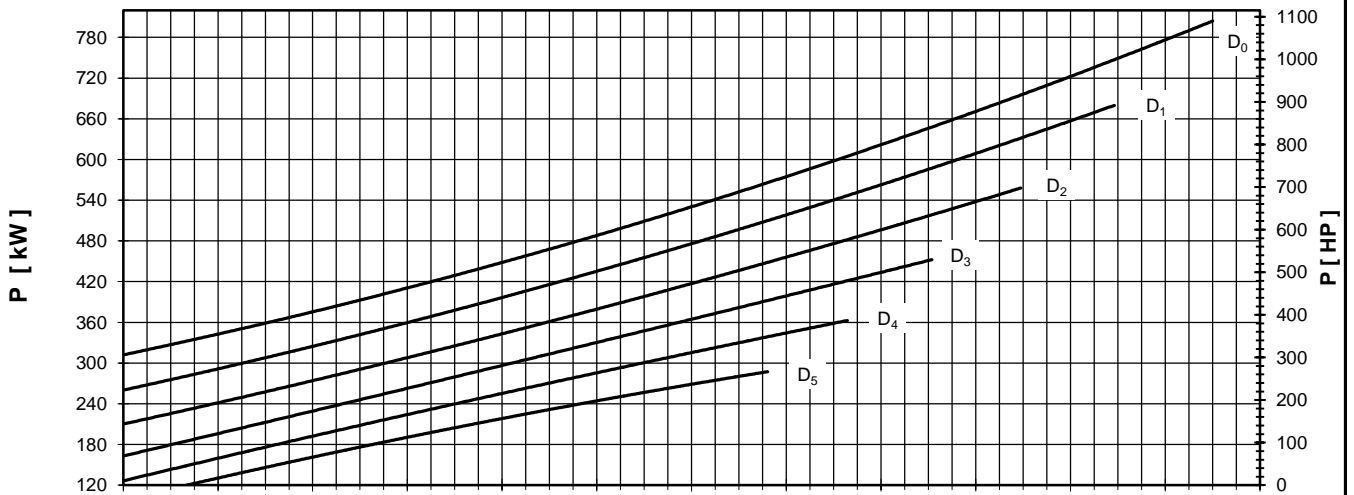
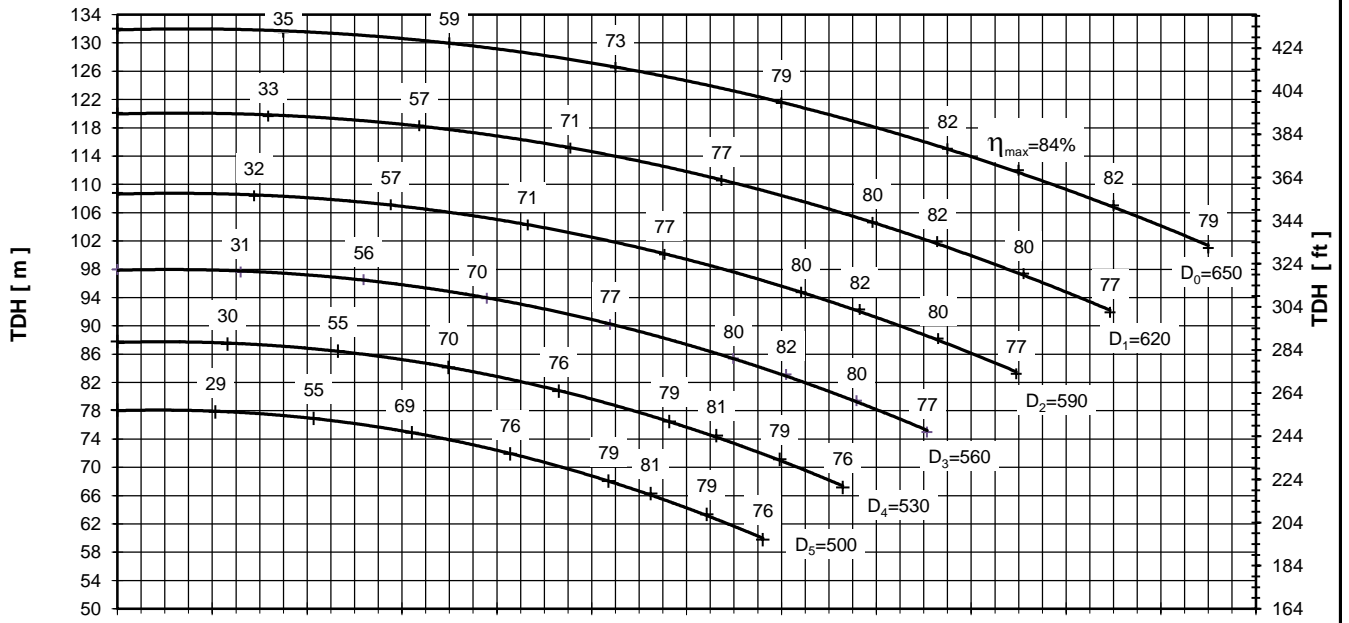

Performance curves are valid for clean cold water-kinematic viscosity 1 [mm²/s], density 1000 [kg/m³]. Methods and tolerances of presented performance curves are in accordance with ISO 9906 - Annex A

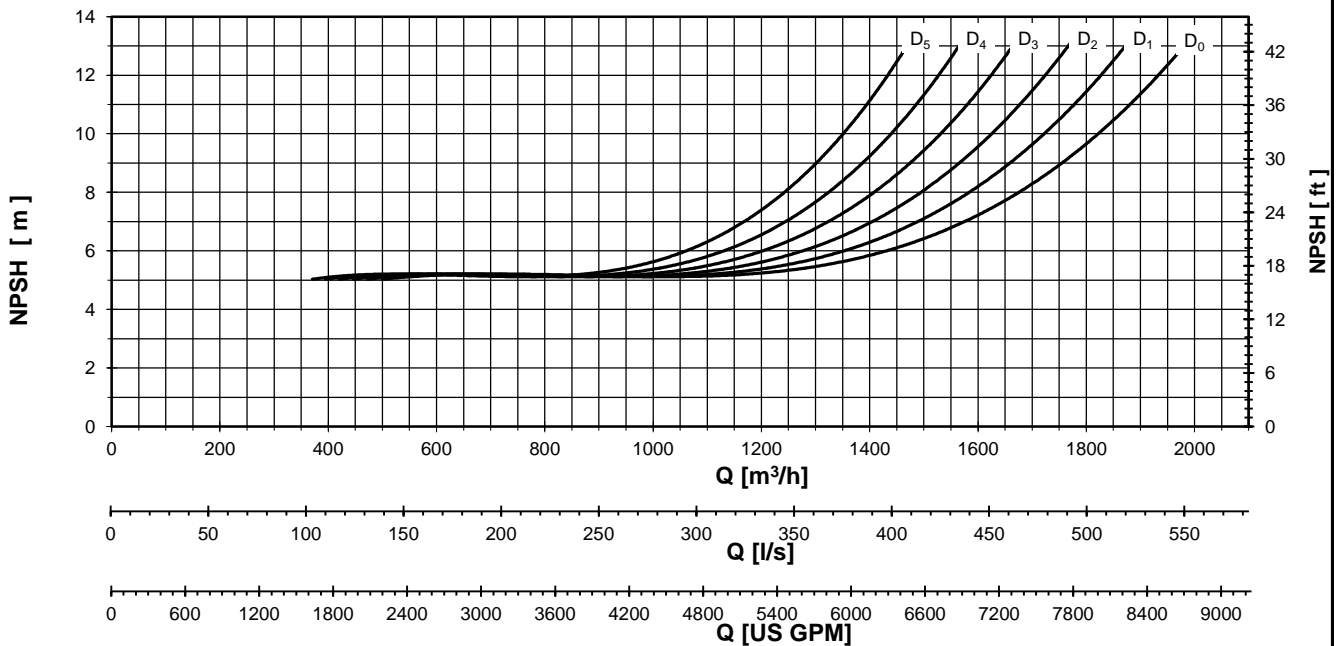
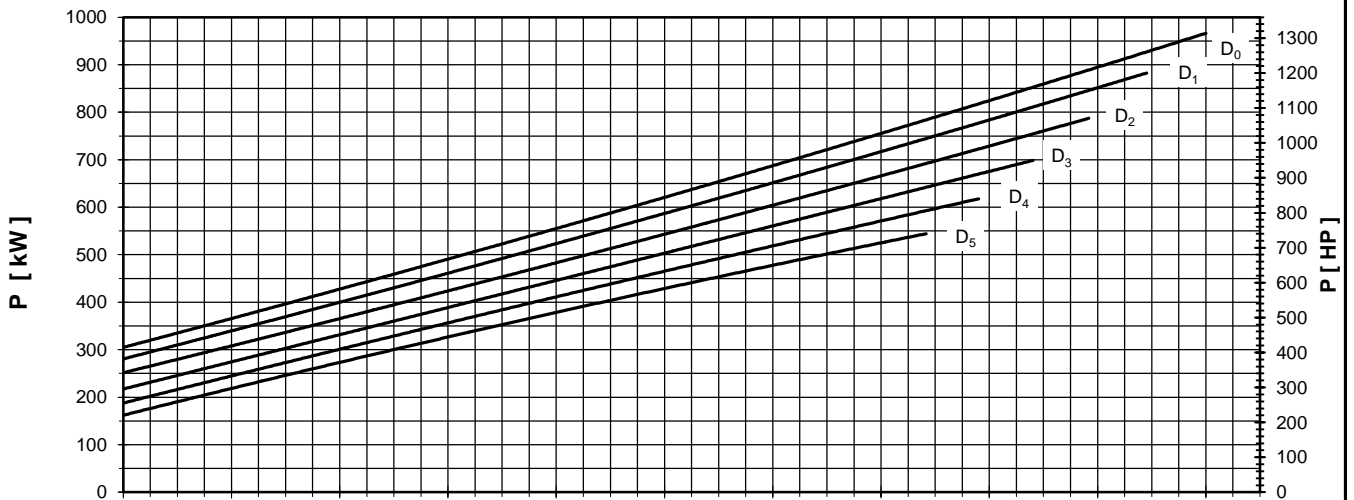
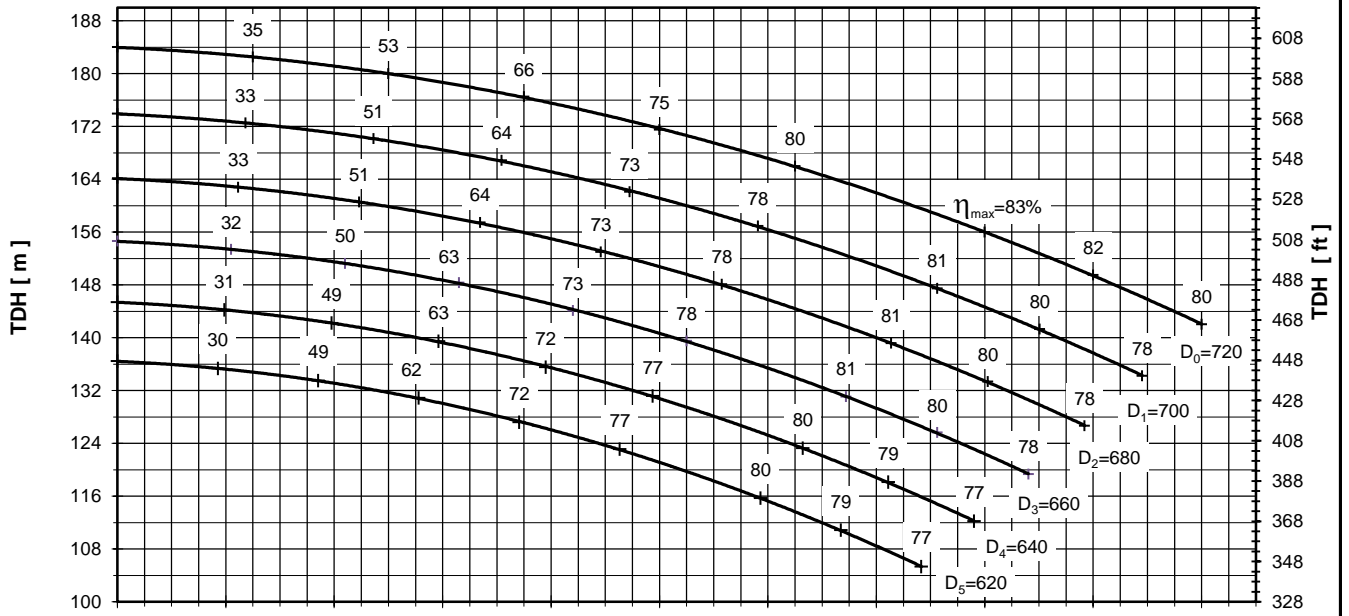

Performance curves are valid for clean cold water-kinematic viscosity 1 [mm²/s], density 1000 [kg/m³]. Methods and tolerances of presented performance curves are in accordance with ISO 9906 - Annex A



PUMP PERFORMANCE CURVES
No. 4HD.0189.03

PUMP TYPE
SCP 350 - 400
1450 [rpm]

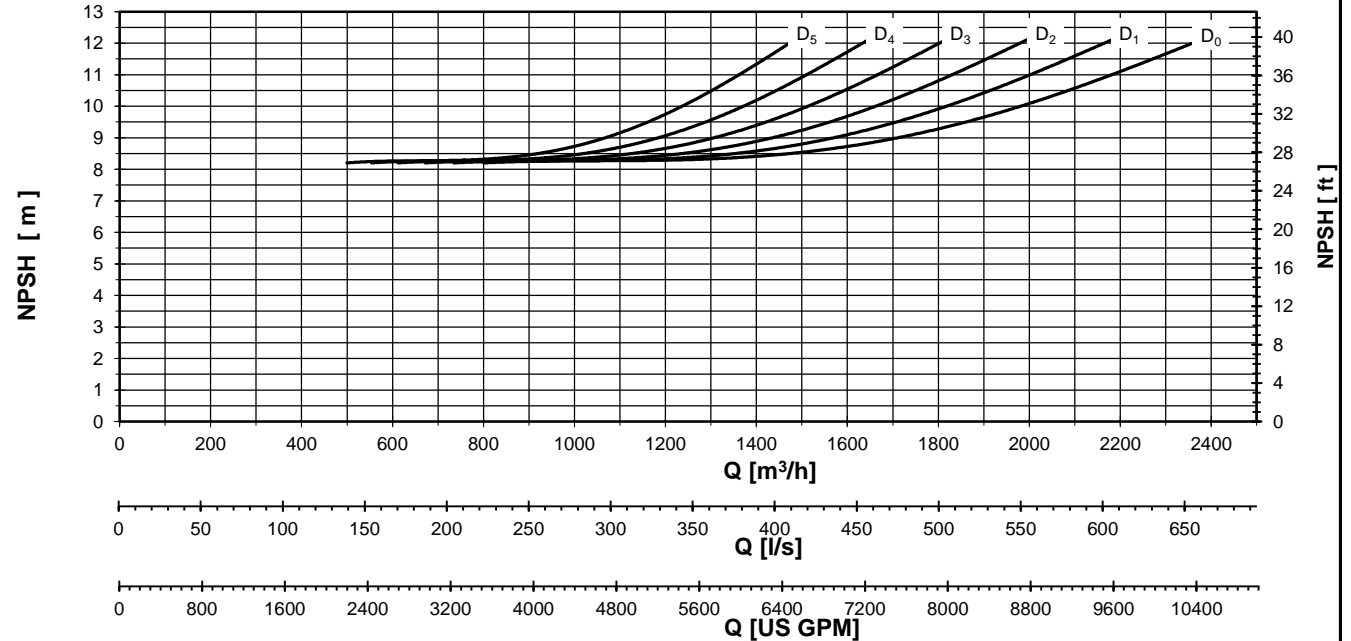
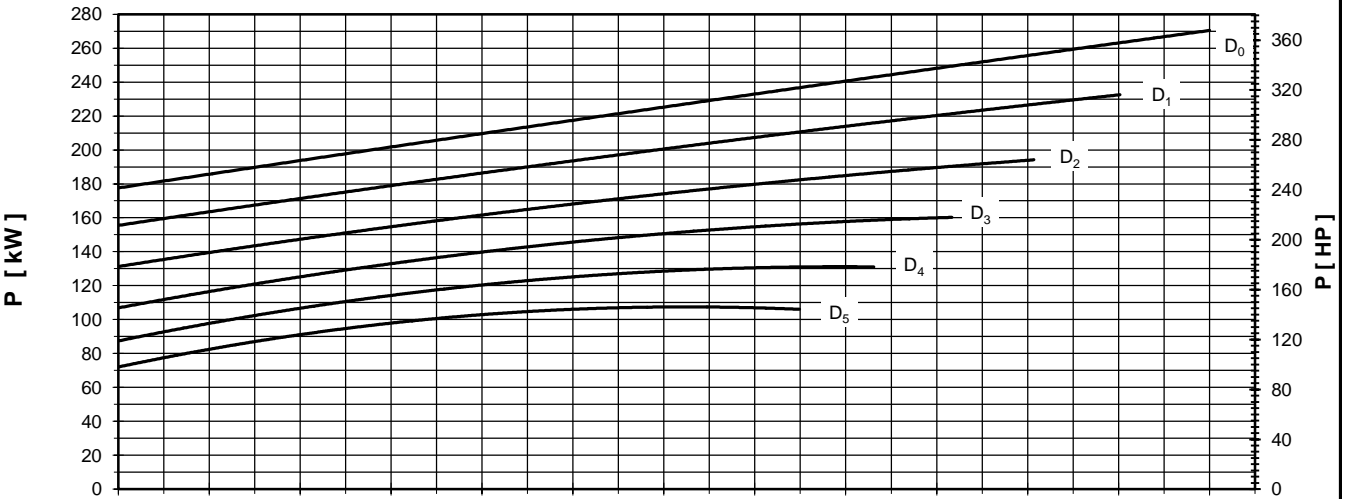
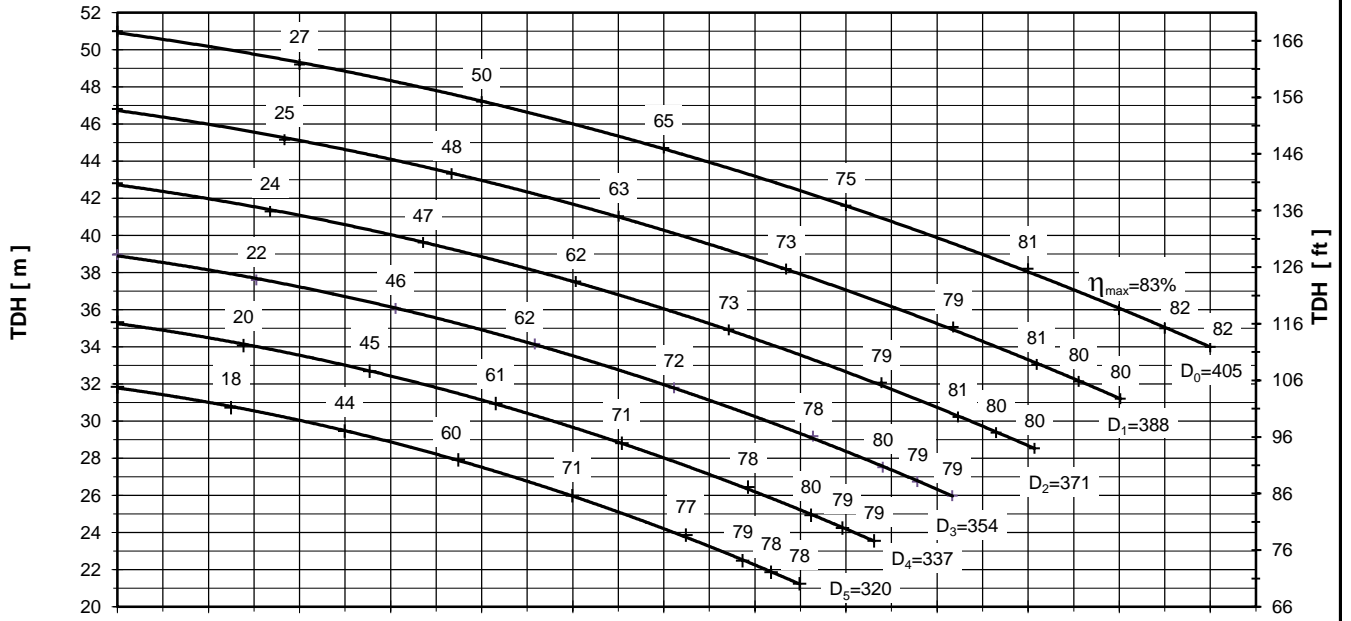

Performance curves are valid for clean cold water-kinematic viscosity 1 [mm²/s], density 1000 [kg/m³]. Methods and tolerances of presented performance curves are in accordance with ISO 9906 - Annex A

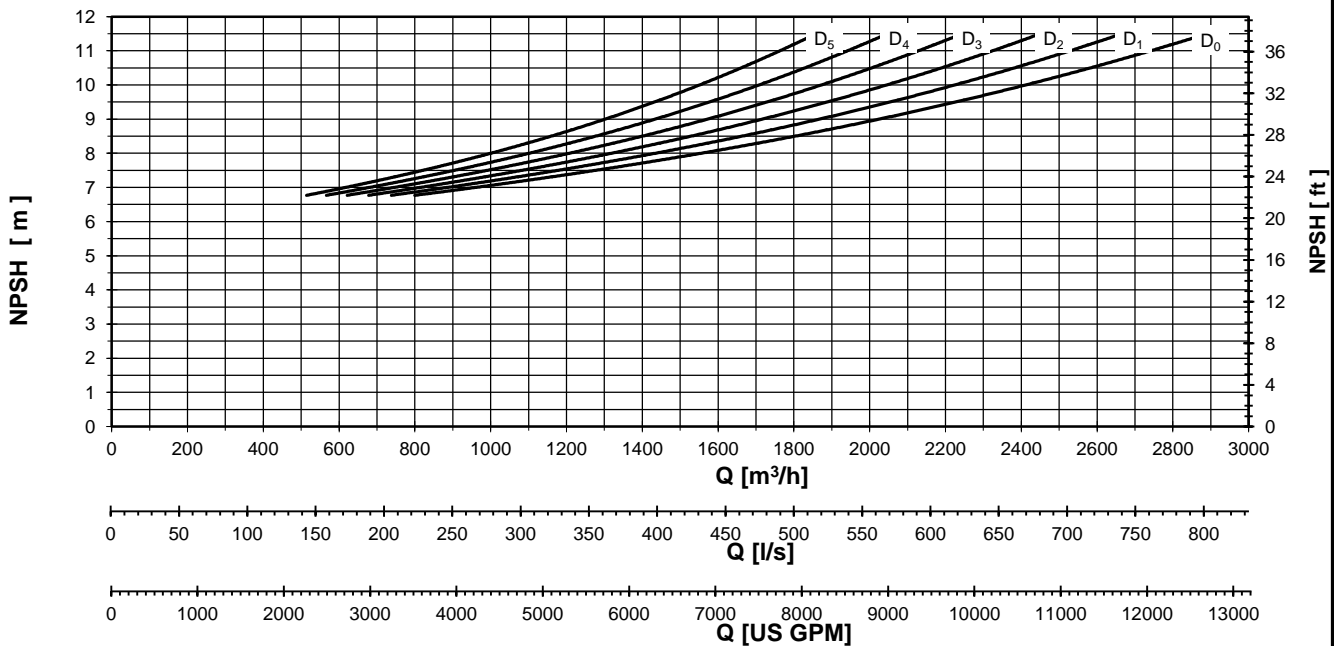
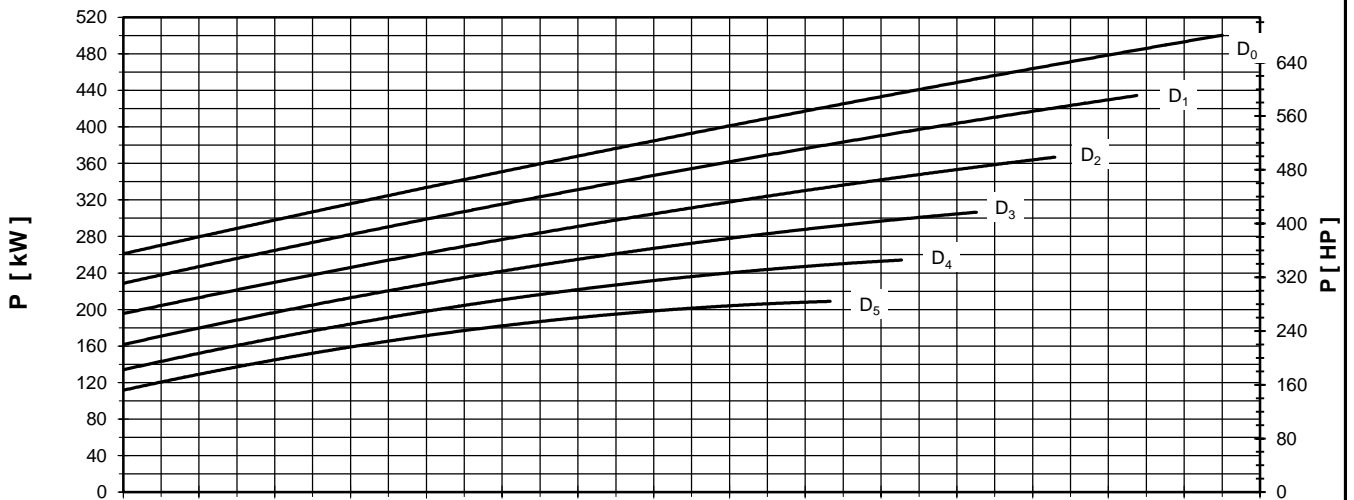
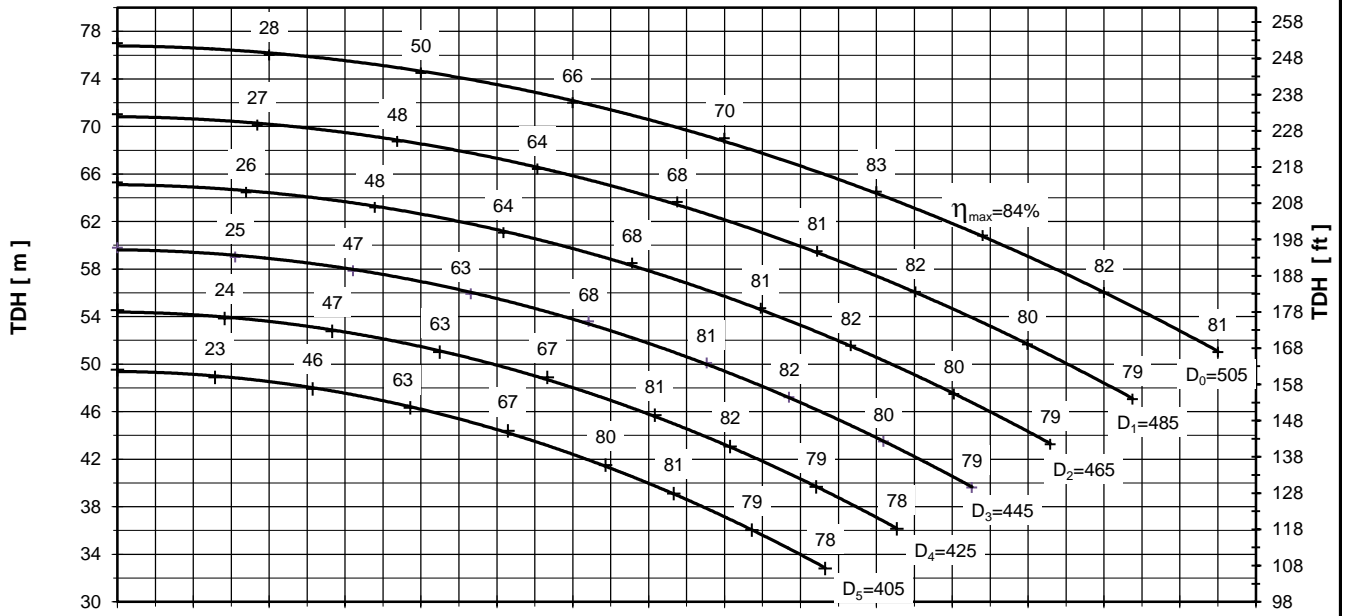

Performance curves are valid for clean cold water-kinematic viscosity 1 [mm²/s], density 1000 [kg/m³]. Methods and tolerances of presented performance curves are in accordance with ISO 9906 - Annex A



PUMP PERFORMANCE CURVES
No. 4HD.0191.03

PUMP TYPE
SCP 350 - 650
1450 [rpm]

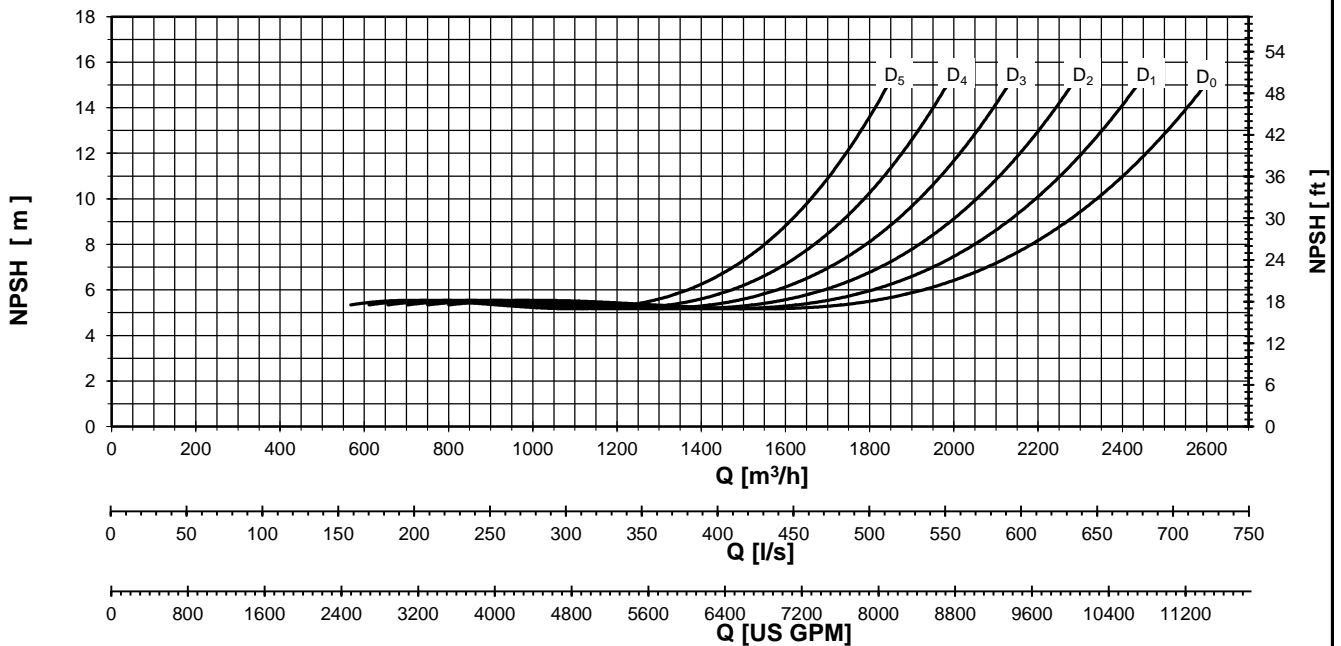
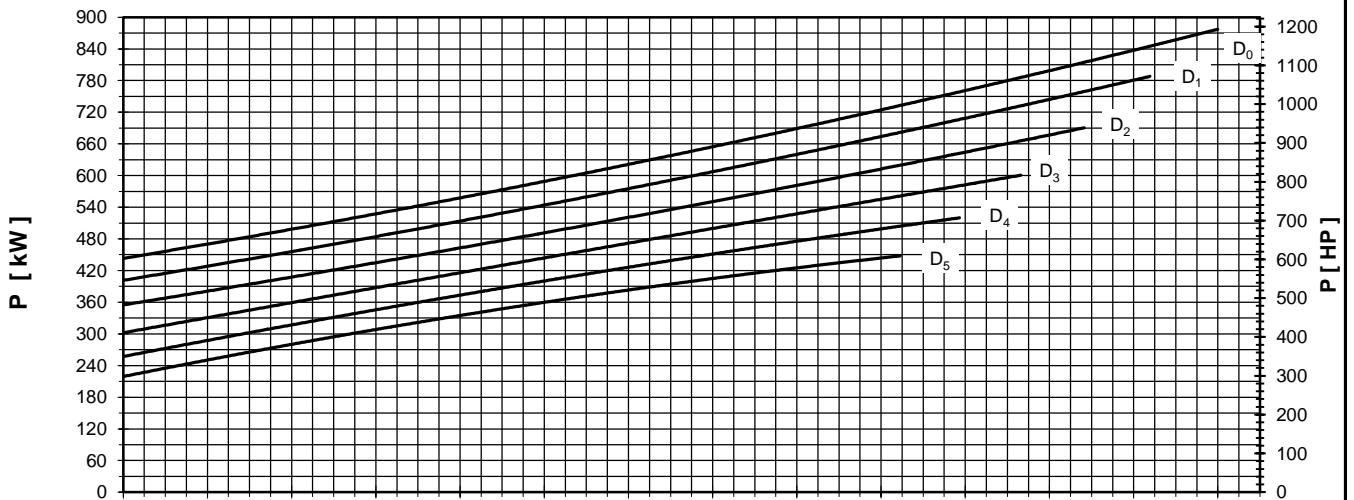
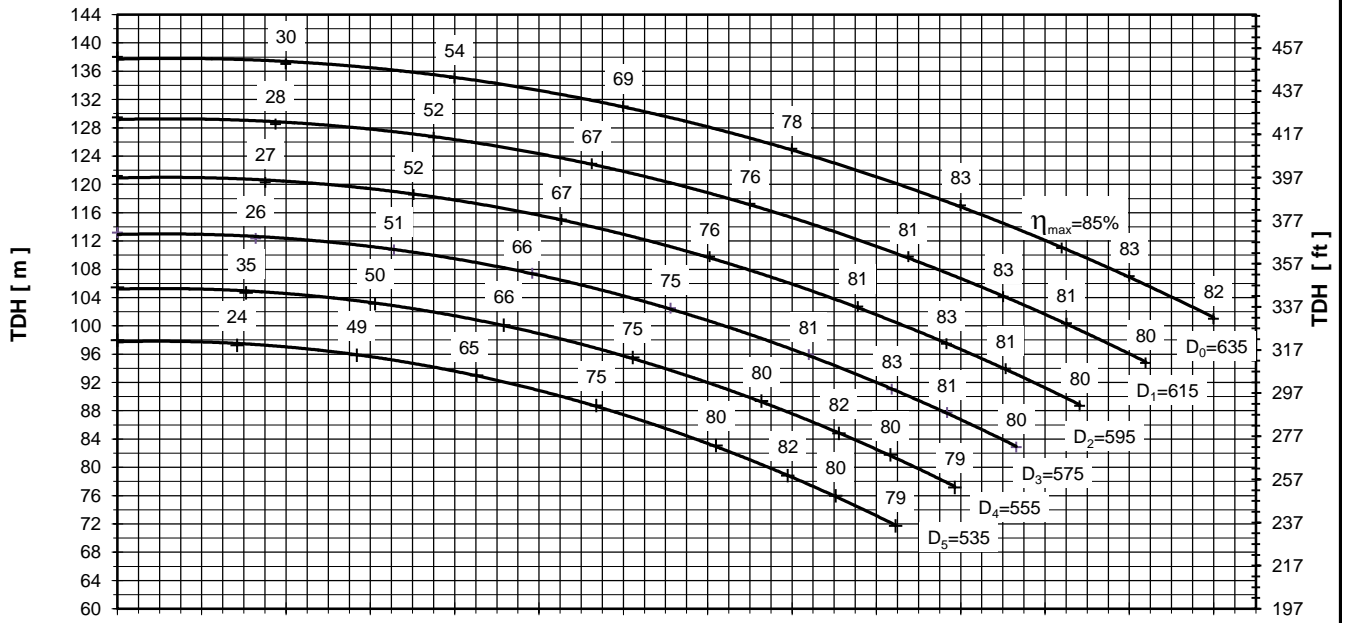

Performance curves are valid for clean cold water-kinematic viscosity 1 [mm²/s], density 1000 [kg/m³]. Methods and tolerances of presented performance curves are in accordance with ISO 9906 - Annex A



PUMP PERFORMANCE CURVES
No. 4HD.0192.03

PUMP TYPE
SCP 350 - 710
1450 [rpm]

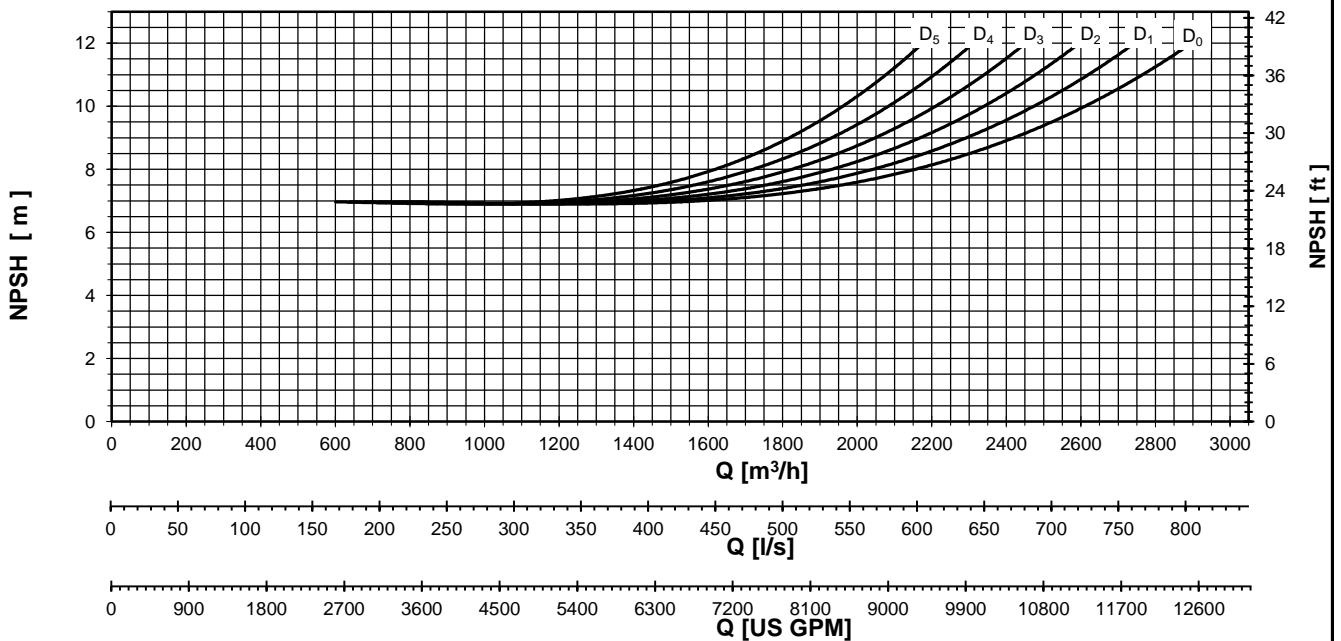
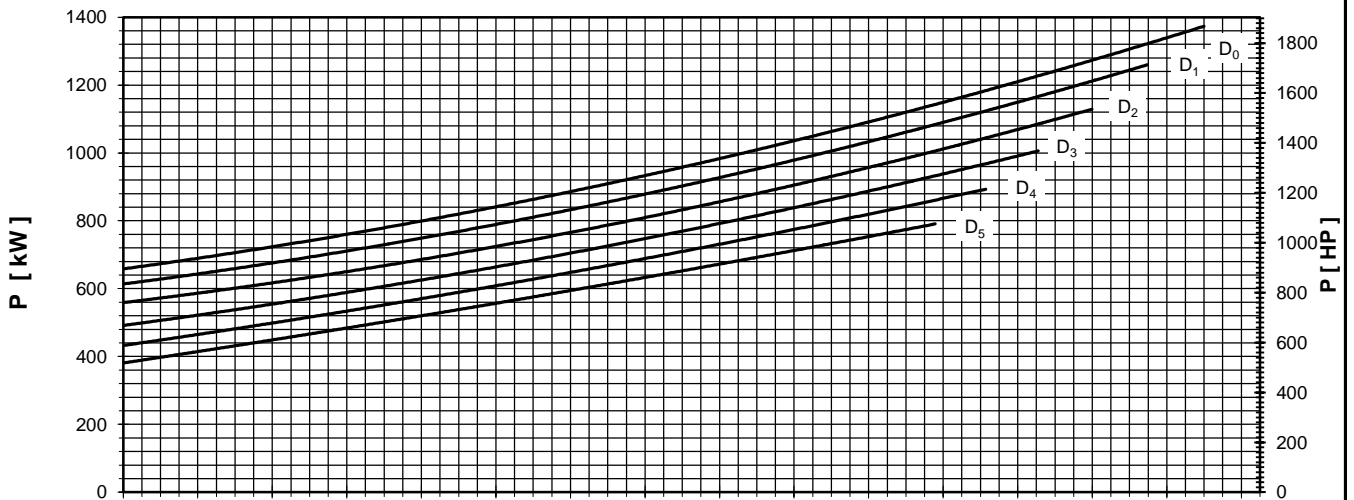
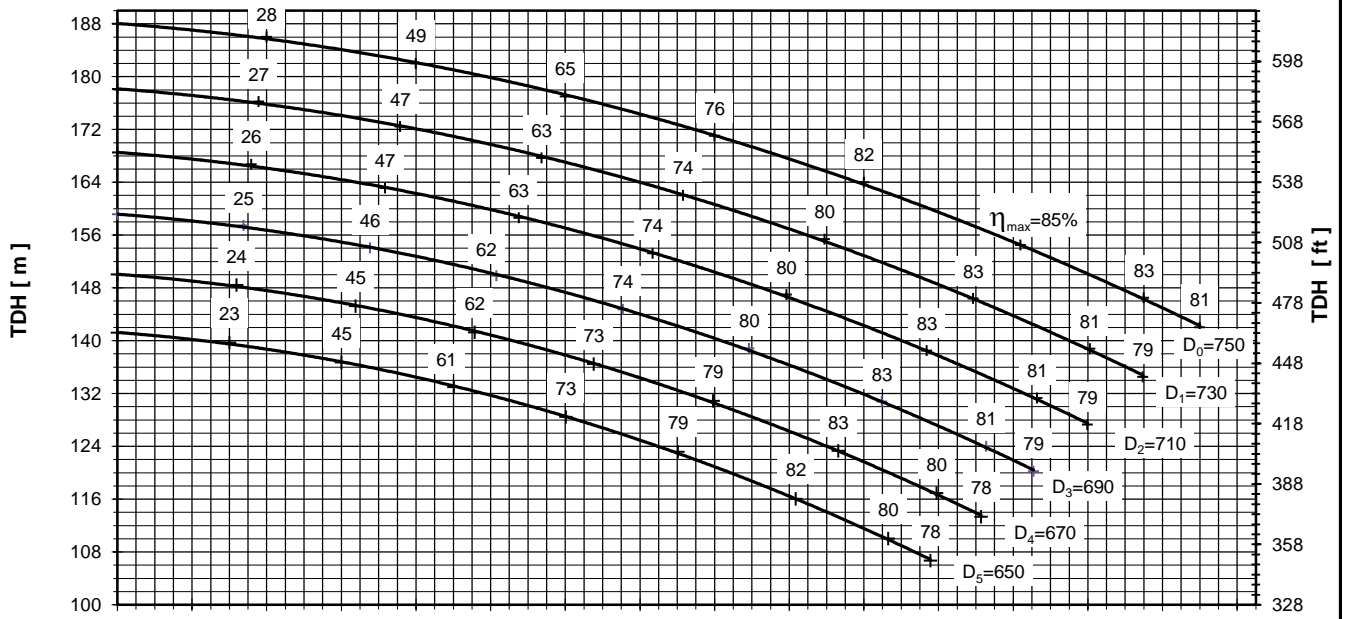

Performance curves are valid for clean cold water-kinematic viscosity 1 [mm²/s], density 1000 [kg/m³]. Methods and tolerances of presented performance curves are in accordance with ISO 9906 - Annex A

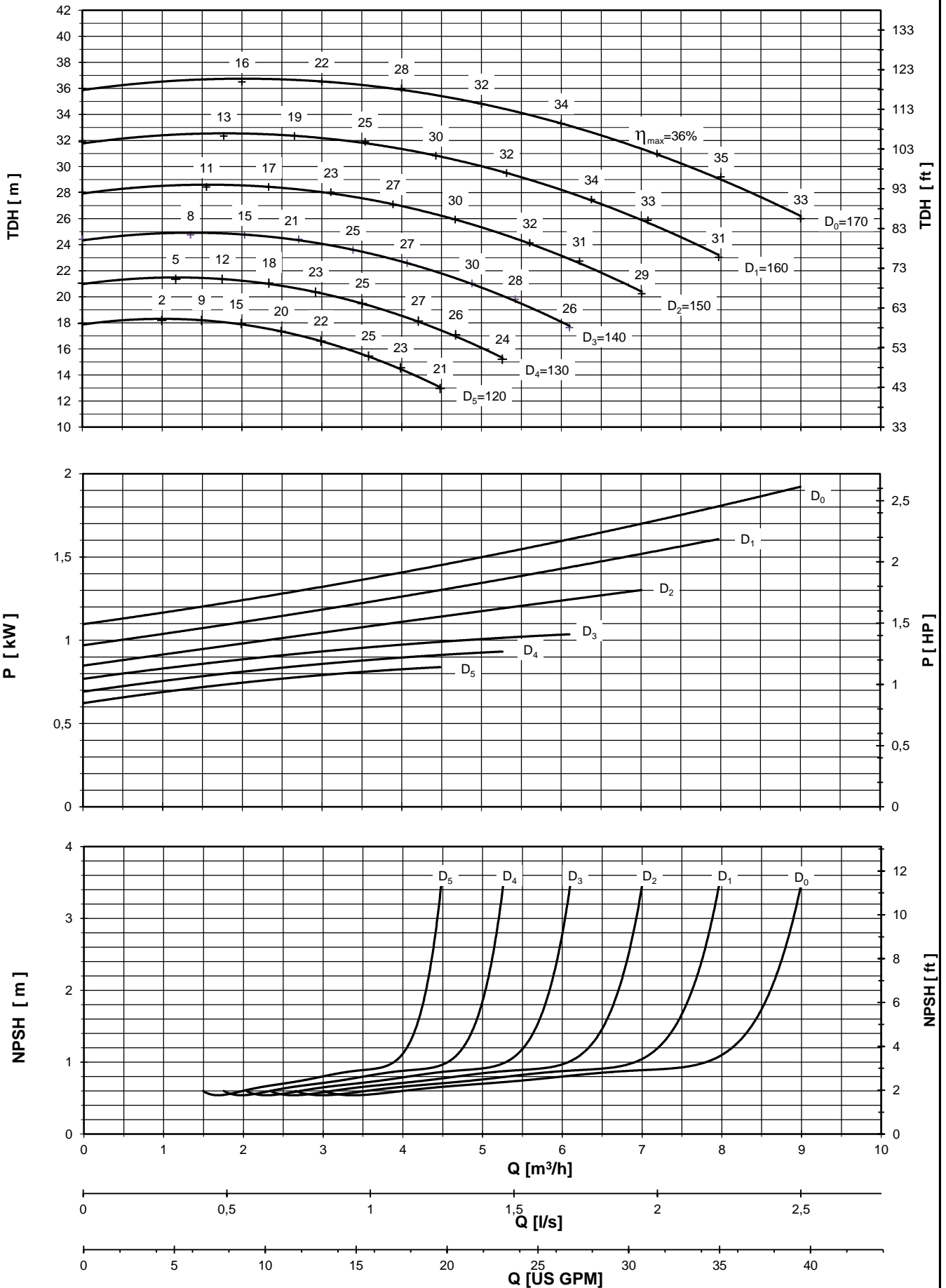

Performance curves are valid for clean cold water-kinematic viscosity 1 [mm²/s], density 1000 [kg/m³]. Methods and tolerances of presented performance curves are in accordance with ISO 9906 - Annex A

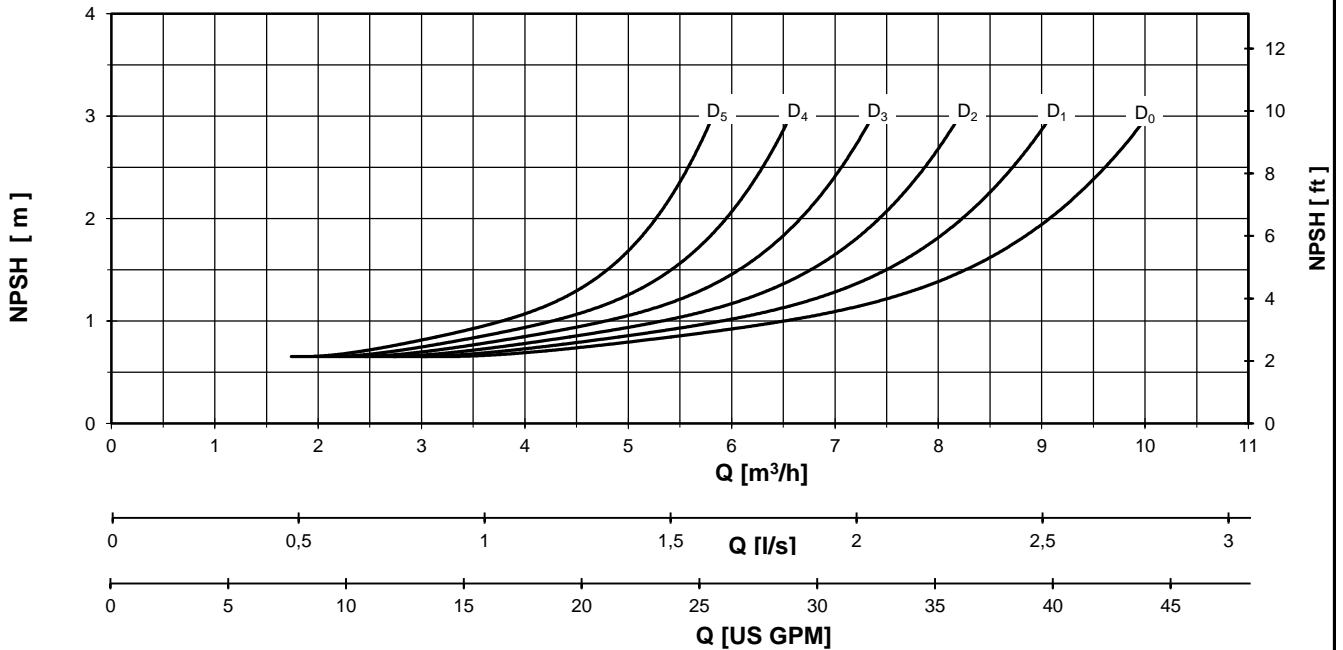
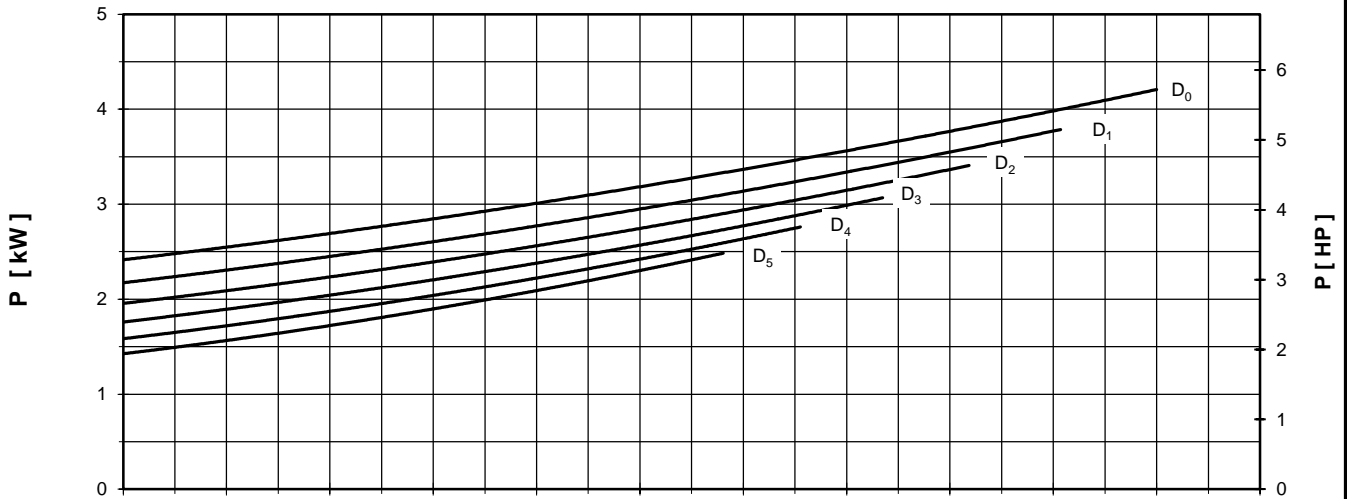
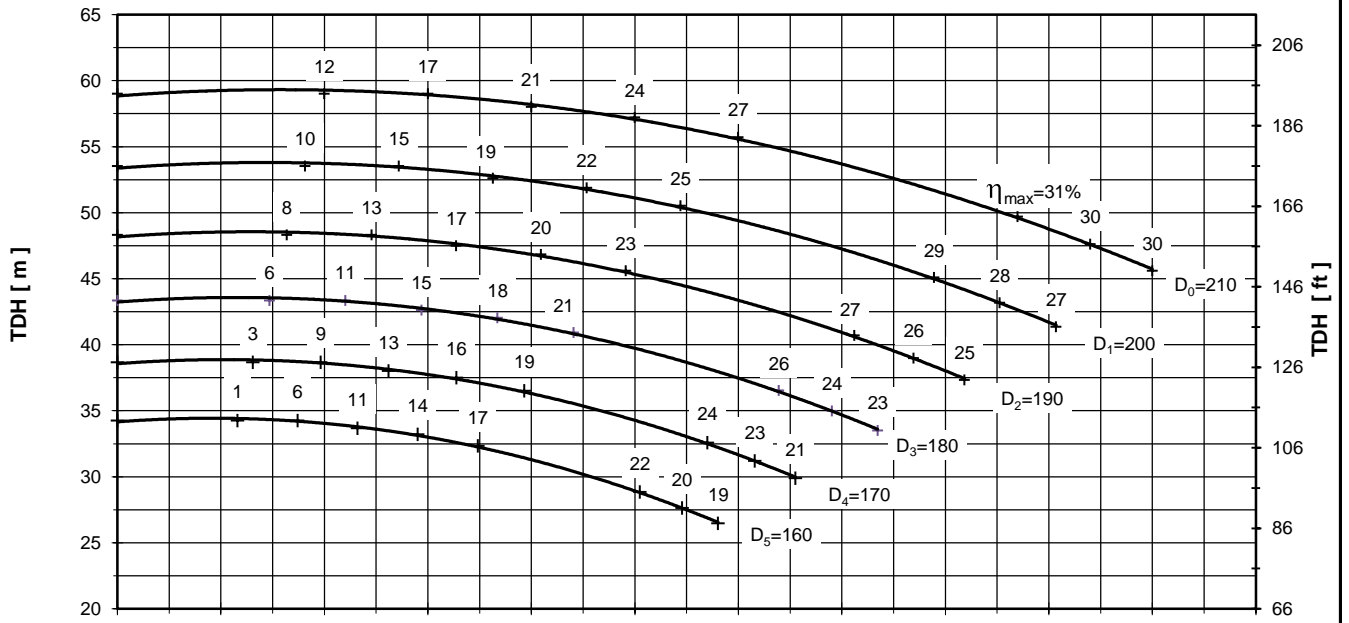

Performance curves are valid for clean cold water-kinematic viscosity 1 [mm²/s], density 1000 [kg/m³]. Methods and tolerances of presented performance curves are in accordance with ISO 9906 - Annex A

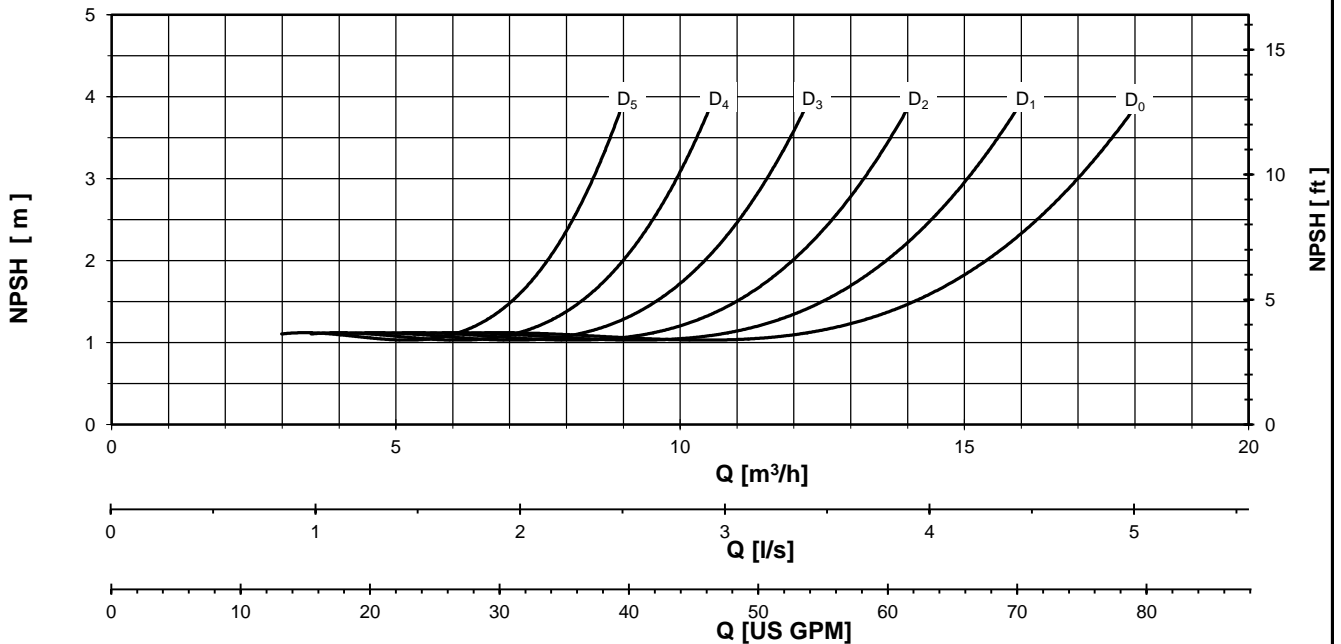
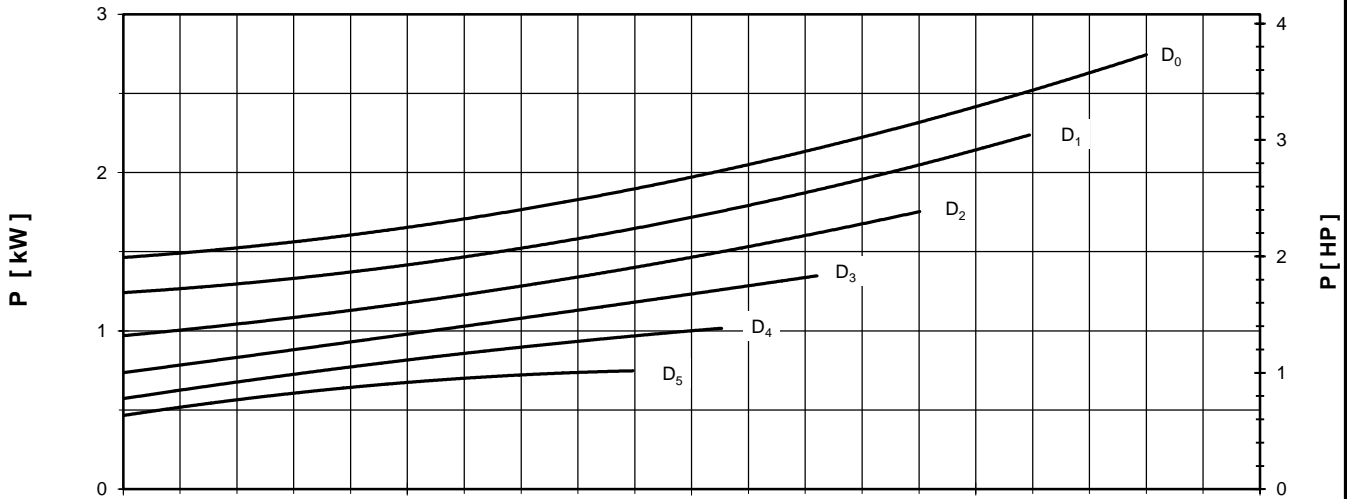
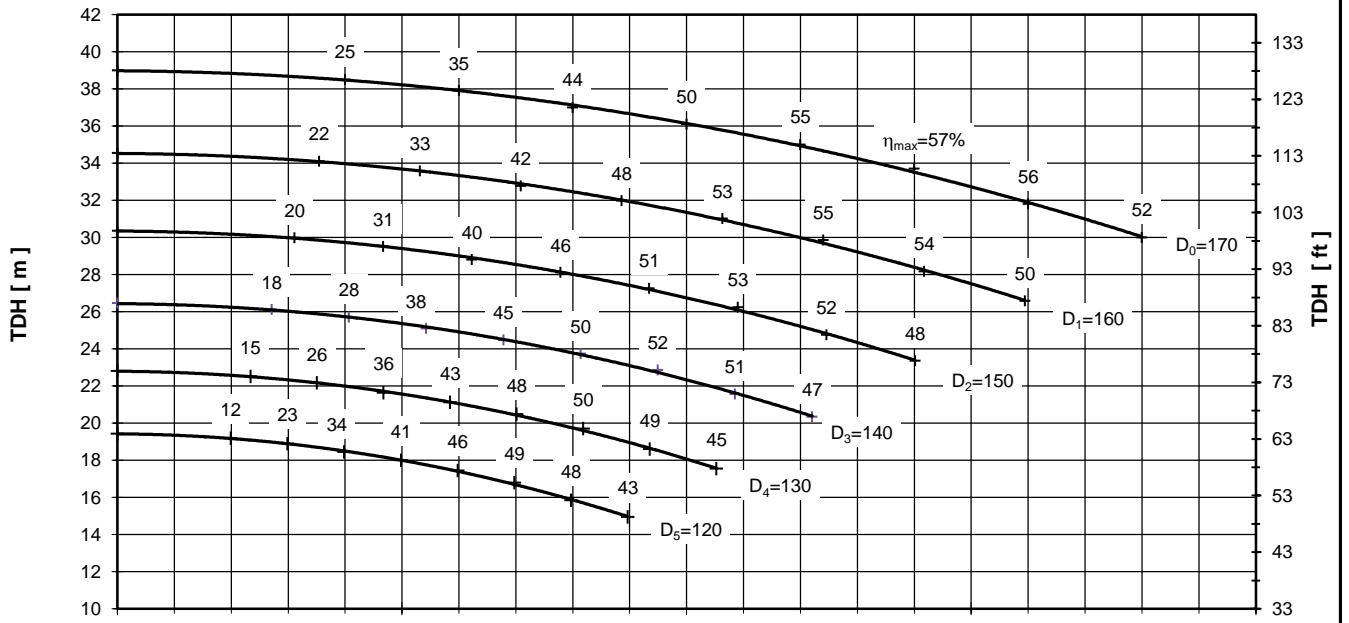



PUMP PERFORMANCE CURVES
No. 4HD.0143.05

PUMP TYPE
SCP 32 - 200
2900 [rpm]

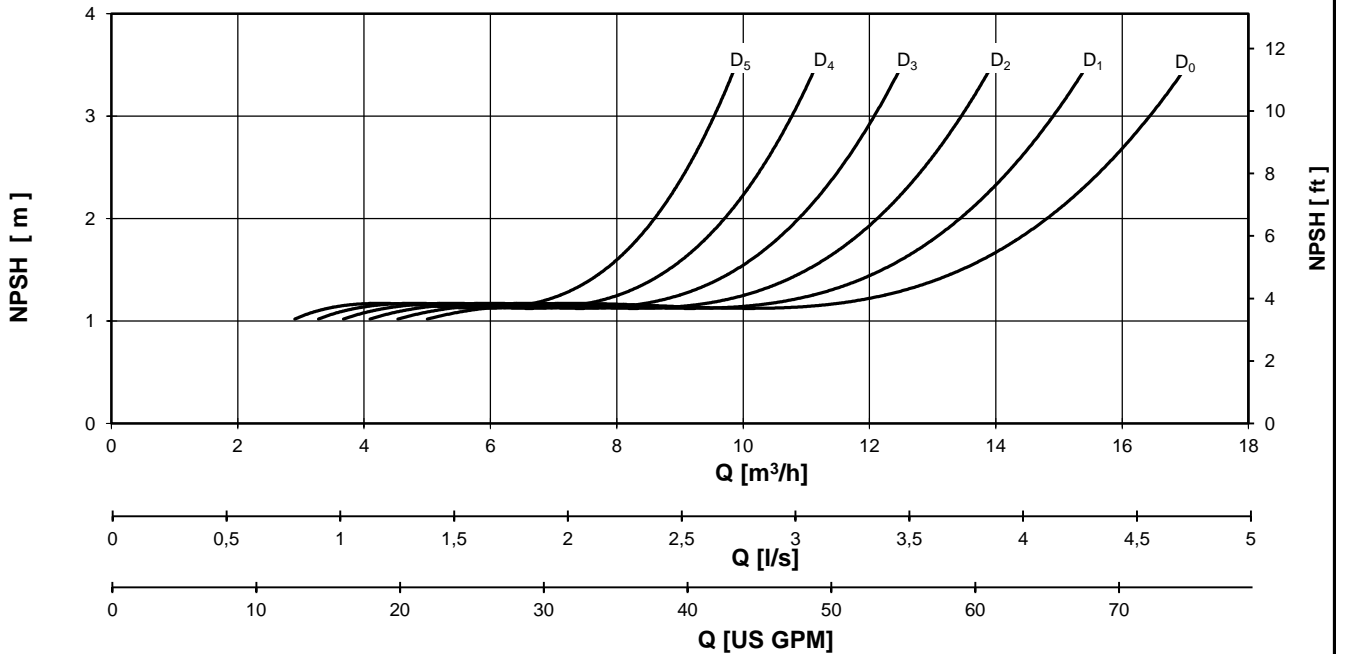
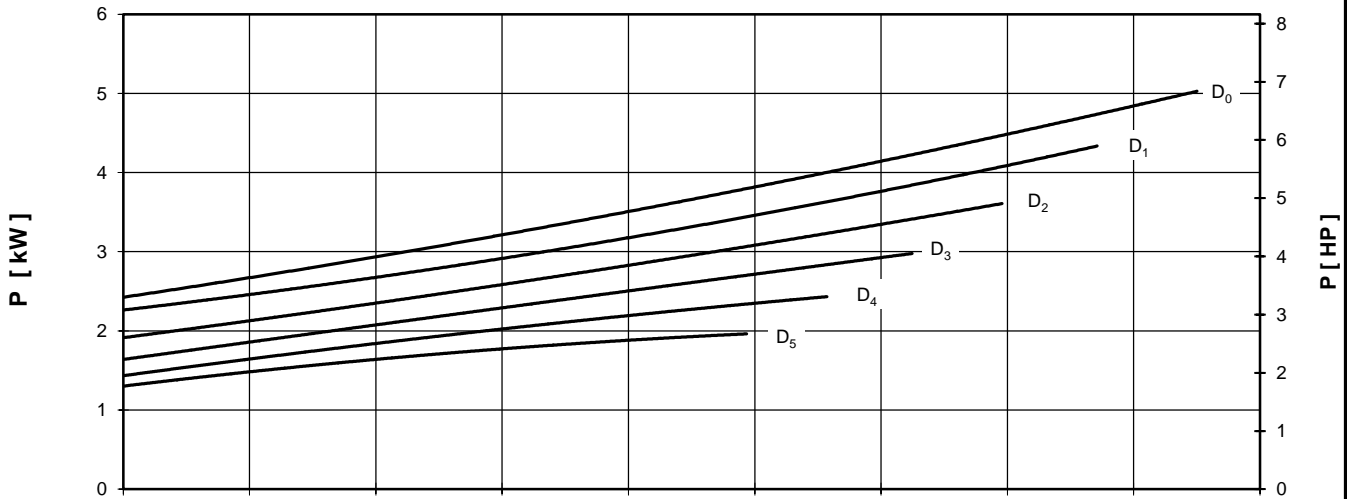
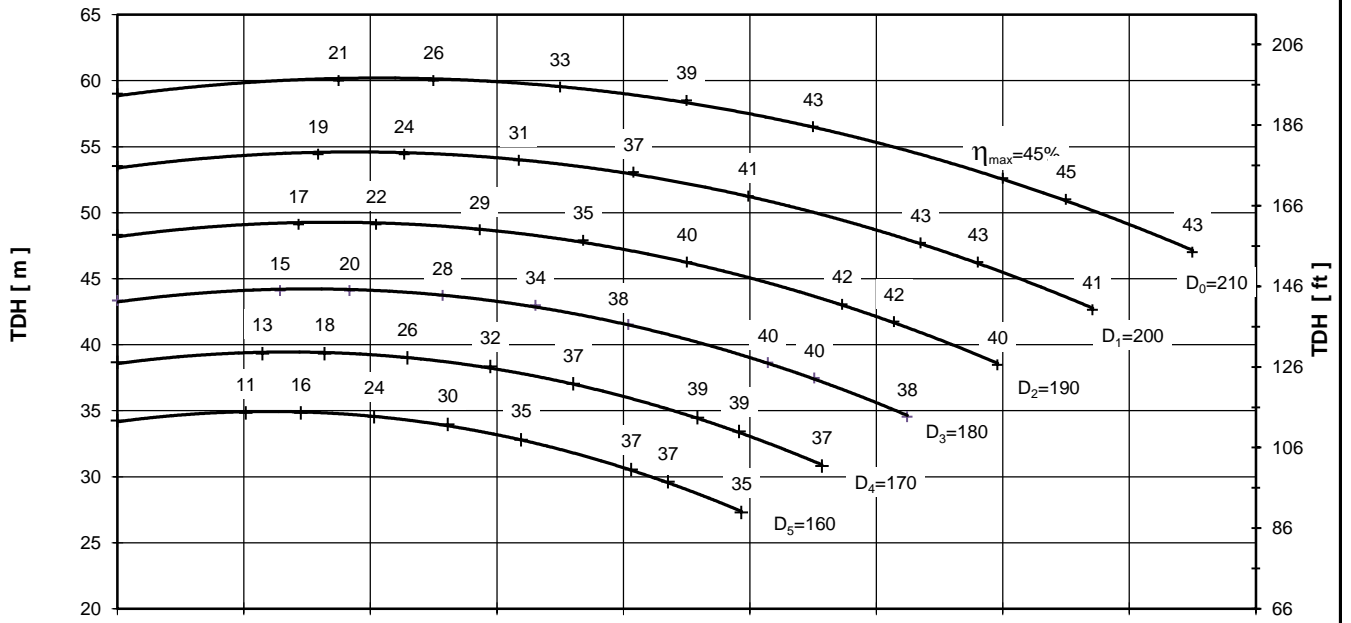

Performance curves are valid for clean cold water-kinematic viscosity 1 [mm²/s], density 1000 [kg/m³]. Methods and tolerances of presented performance curves are in accordance with ISO 9906 - Annex A

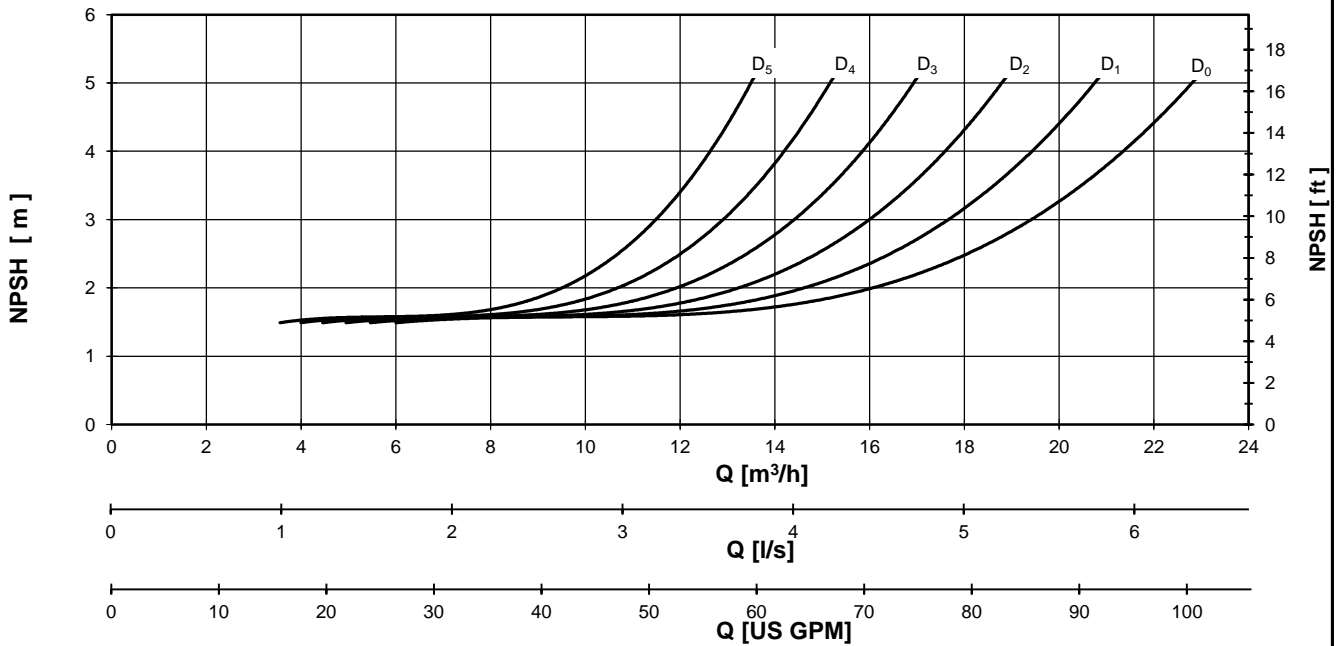
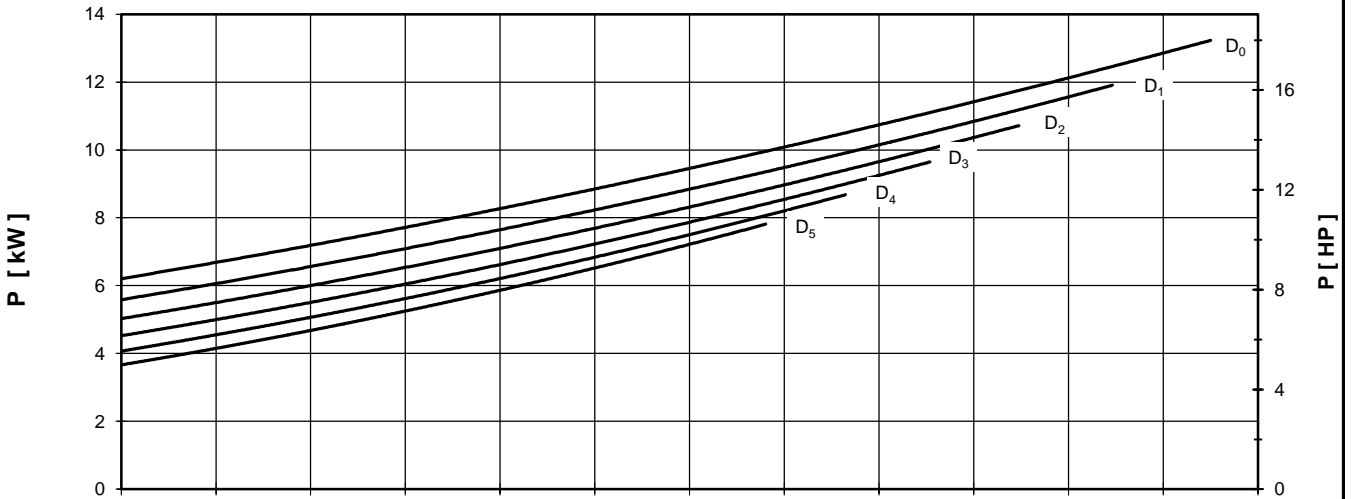
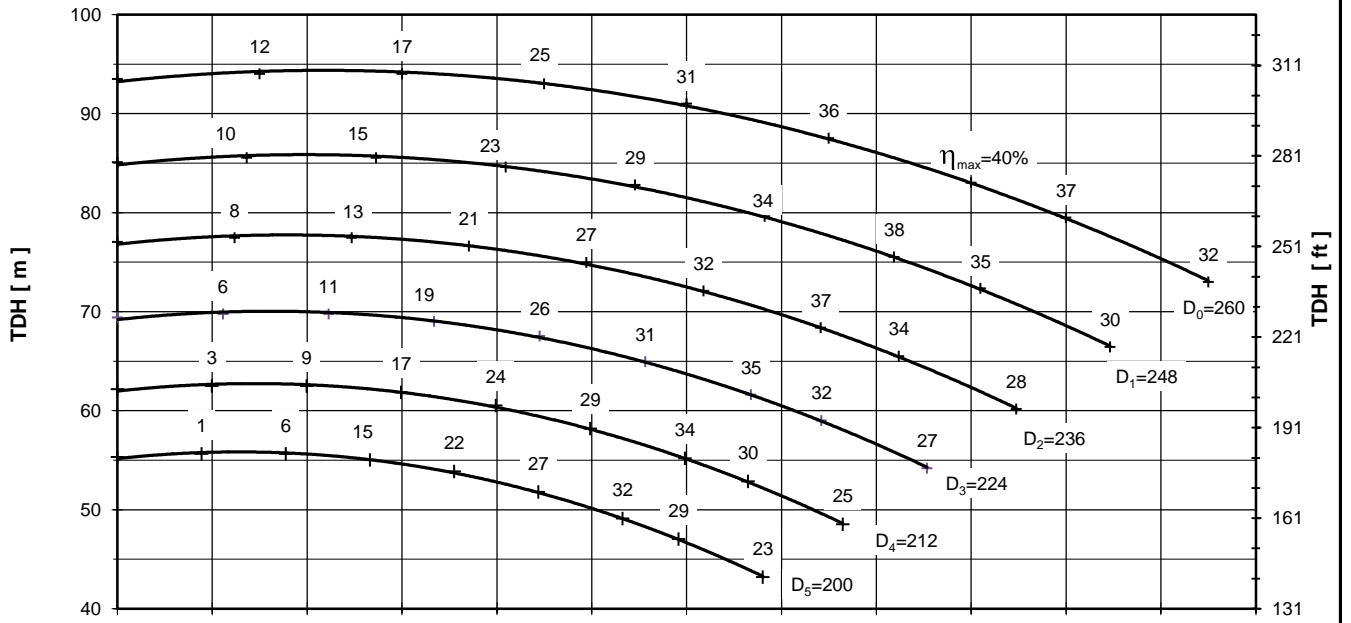

Performance curves are valid for clean cold water-kinematic viscosity 1 [mm²/s], density 1000 [kg/m³]. Methods and tolerances of presented performance curves are in accordance with ISO 9906 - Annex A

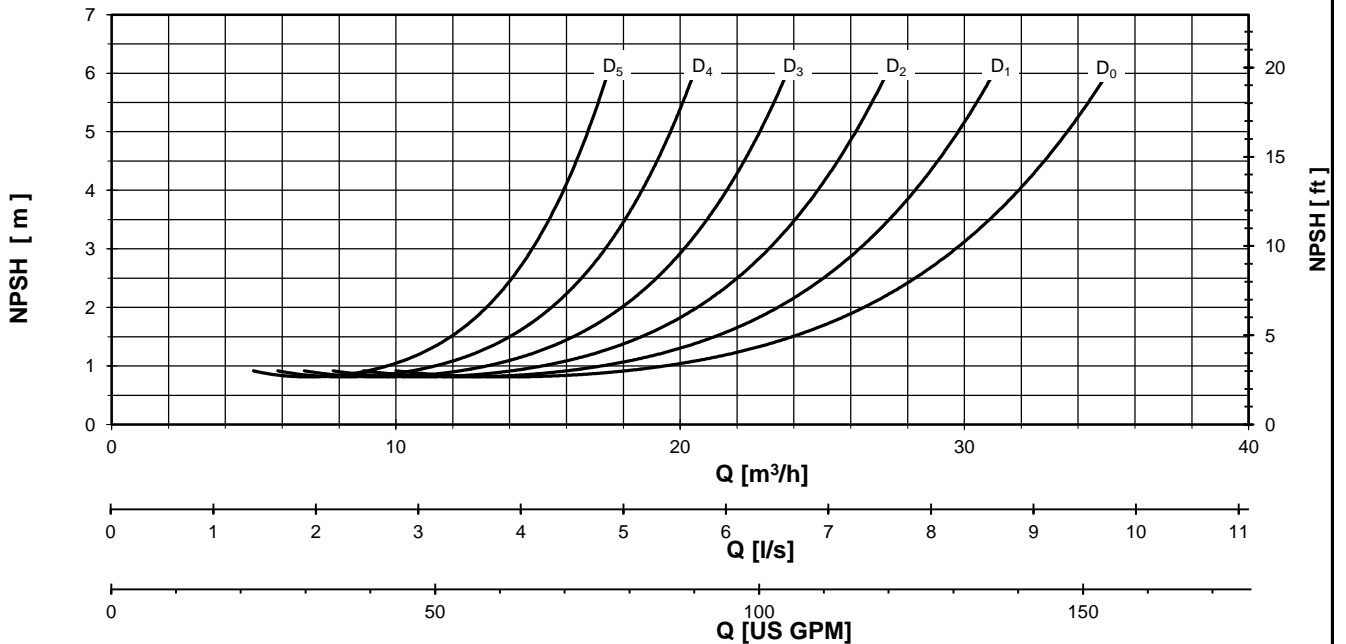
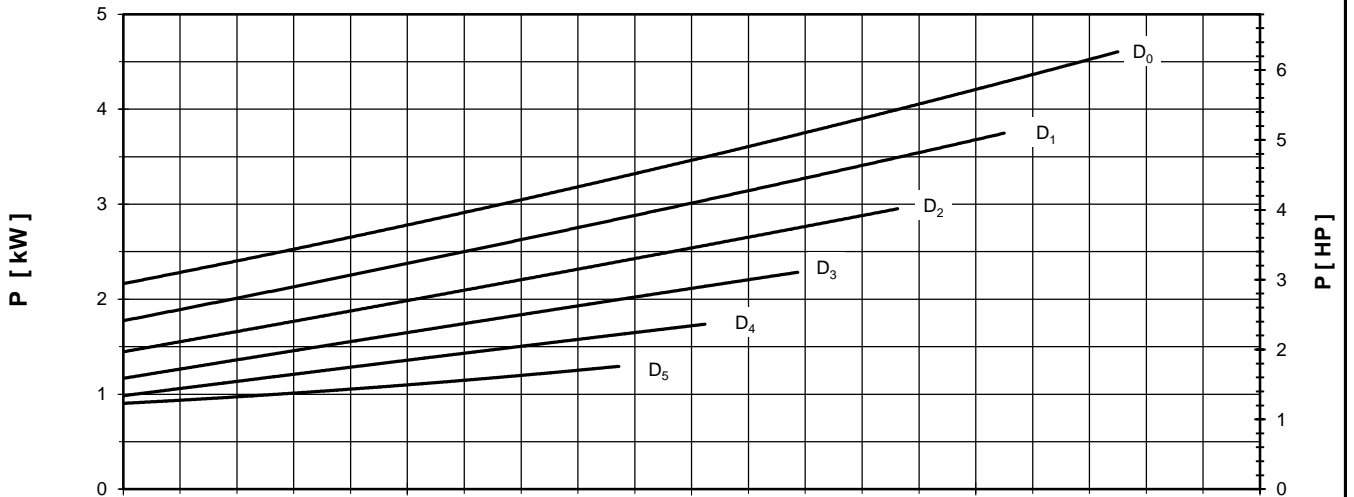
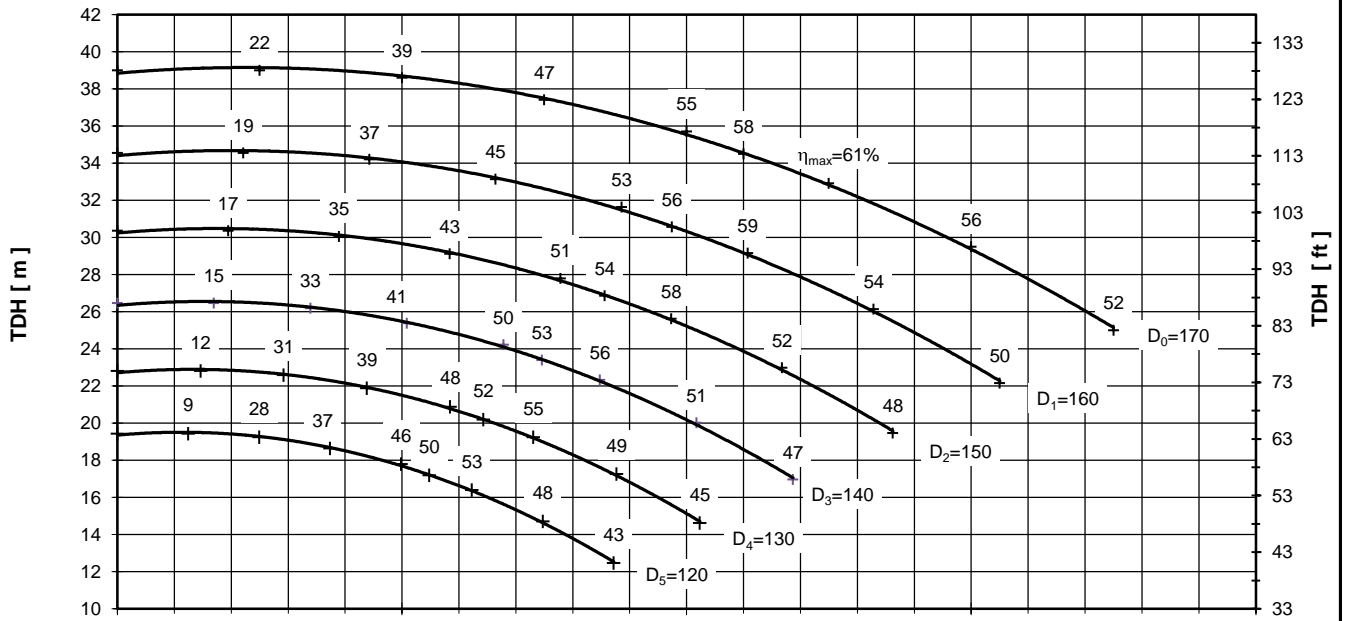

Performance curves are valid for clean cold water-kinematic viscosity 1 [mm²/s], density 1000 [kg/m³]. Methods and tolerances of presented performance curves are in accordance with ISO 9906 - Annex A



PUMP PERFORMANCE CURVES
No. 4HD.0147.05

PUMP TYPE
SCP 40 - 200
2900 [rpm]

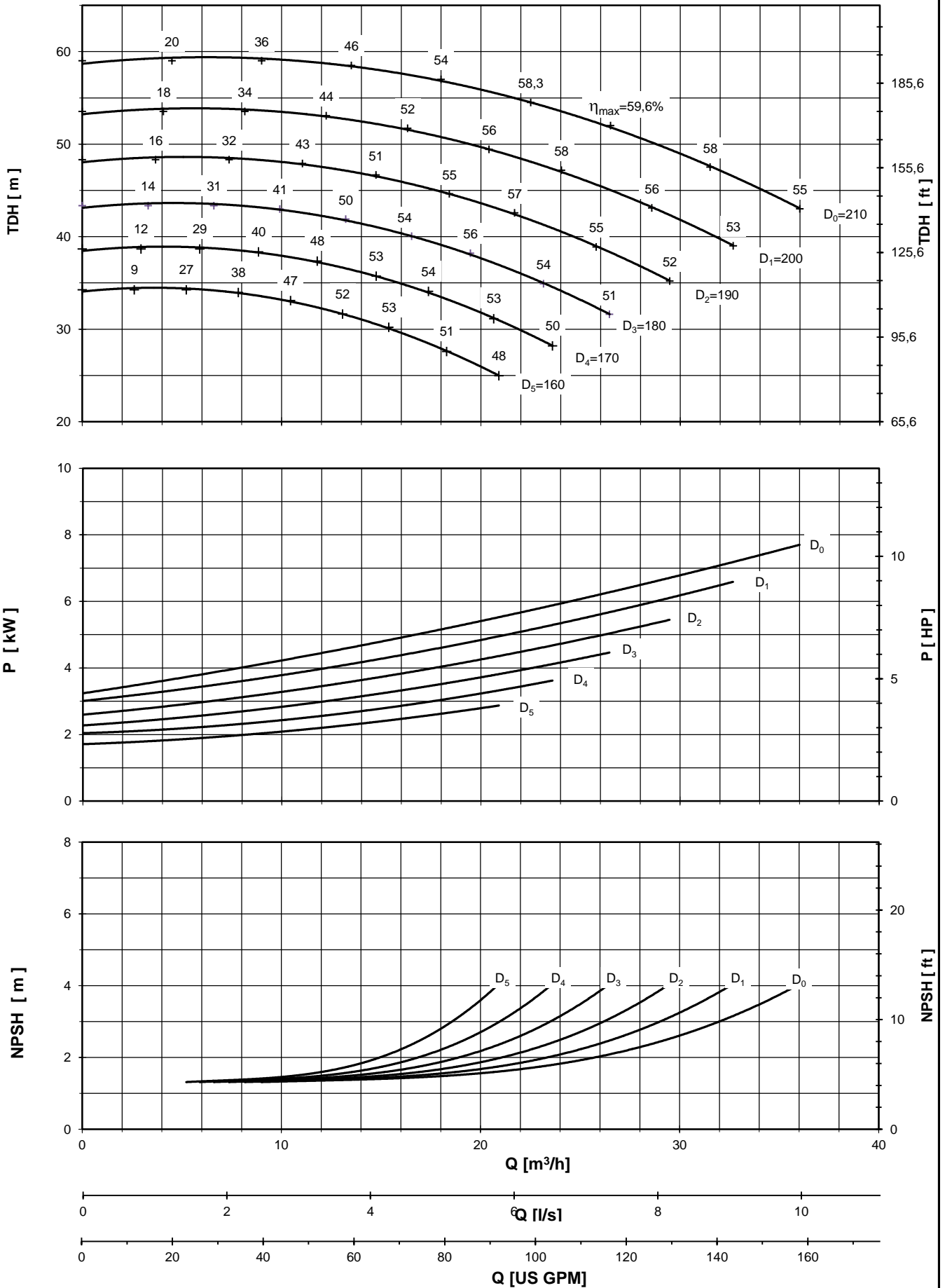

Performance curves are valid for clean cold water-kinematic viscosity 1 [mm²/s], density 1000 [kg/m³]. Methods and tolerances of presented performance curves are in accordance with ISO 9906 - Annex A

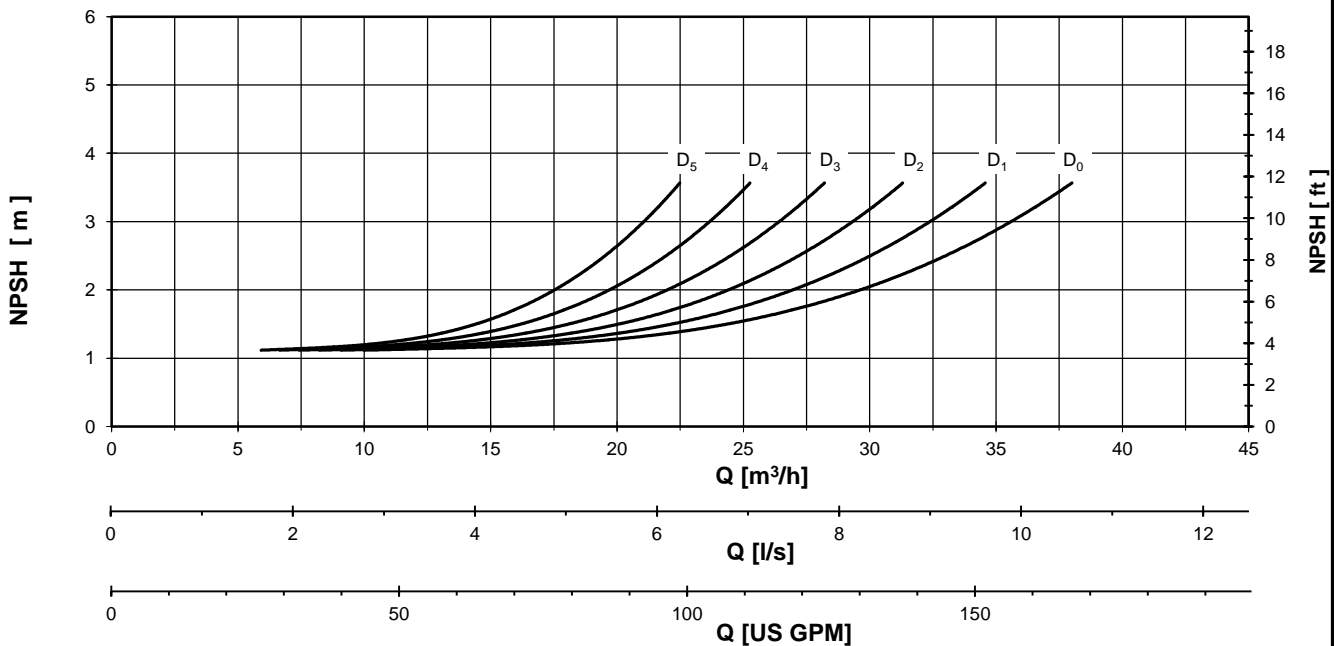
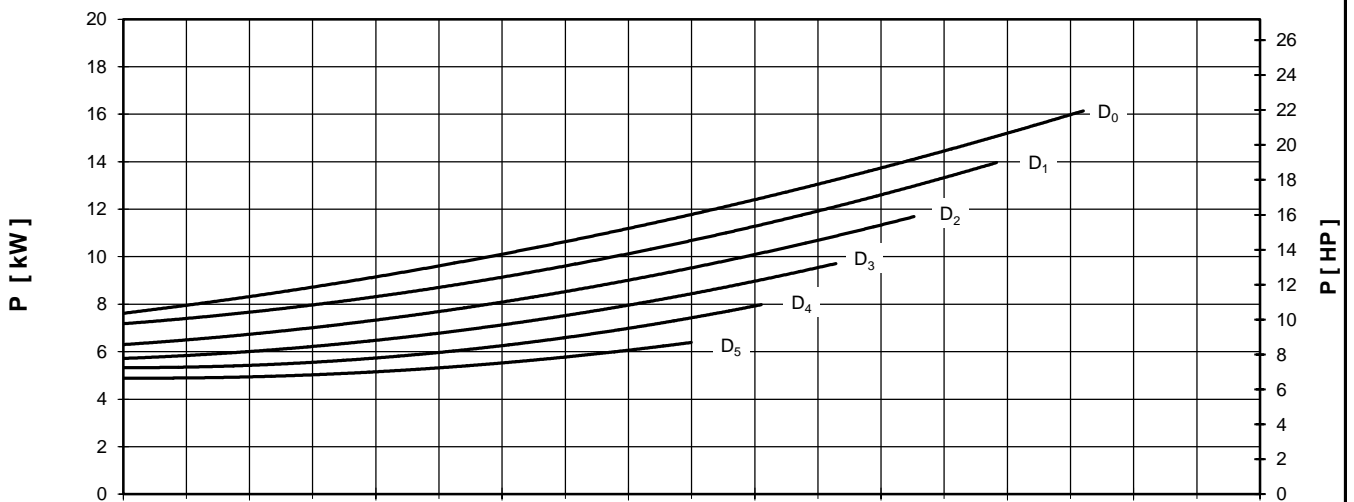
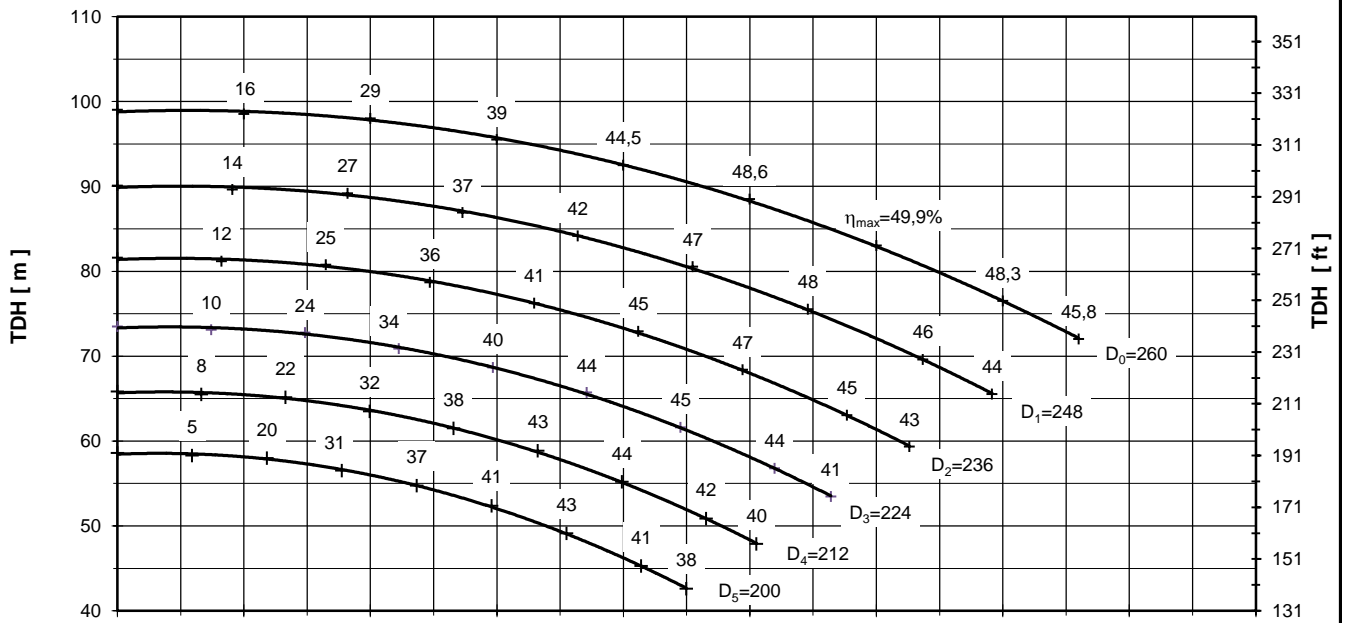

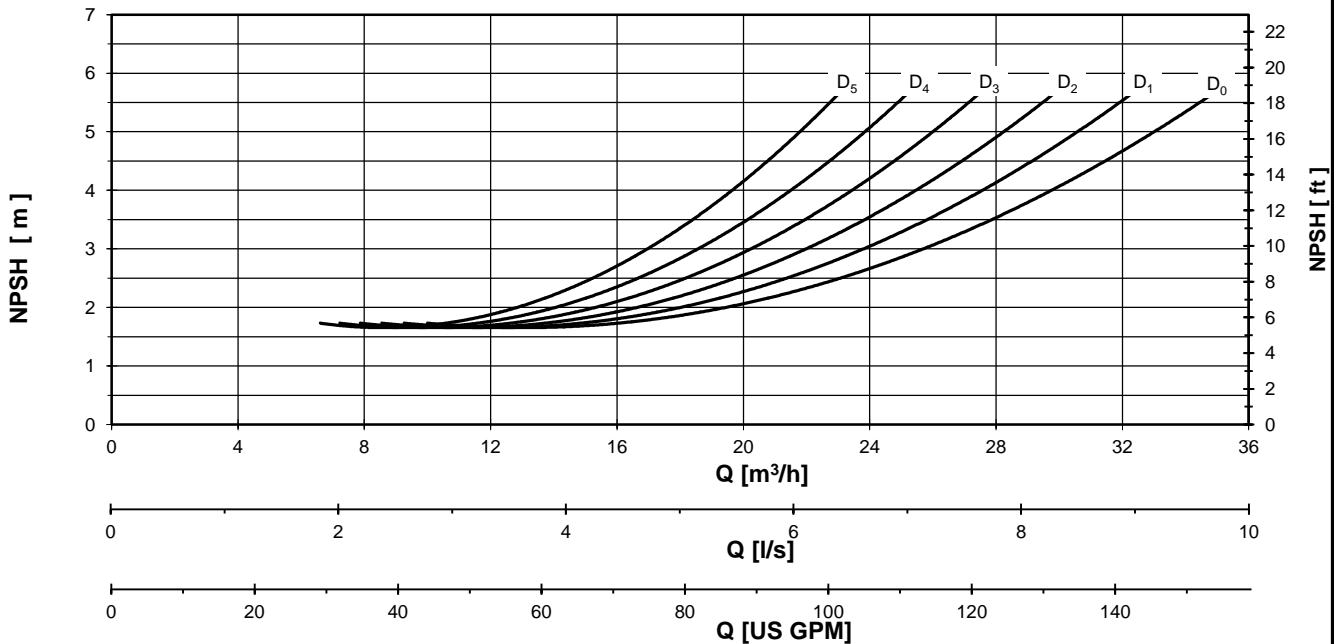
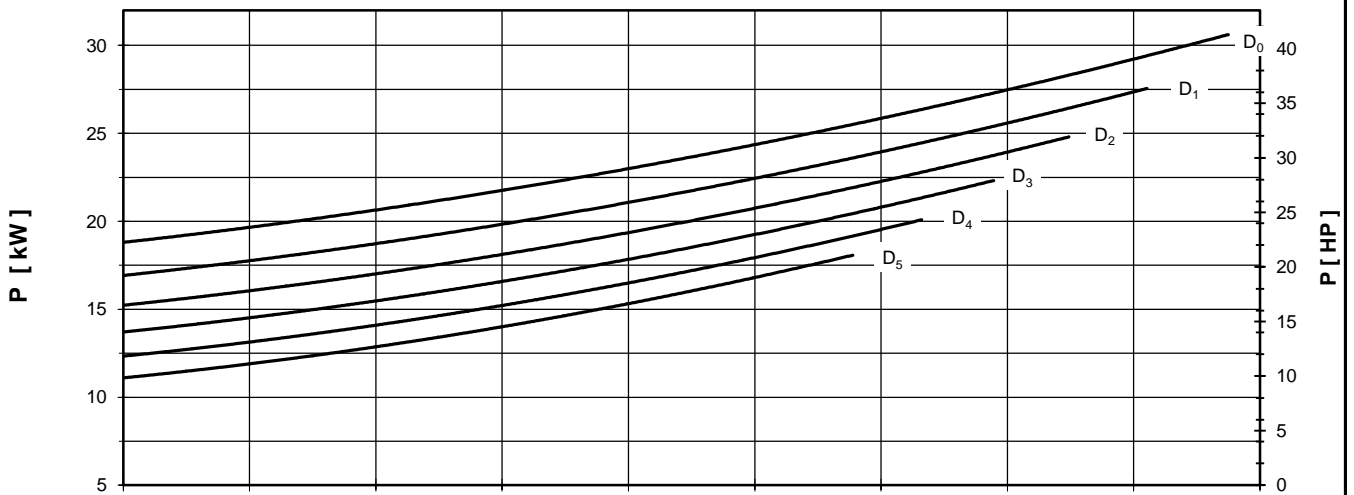
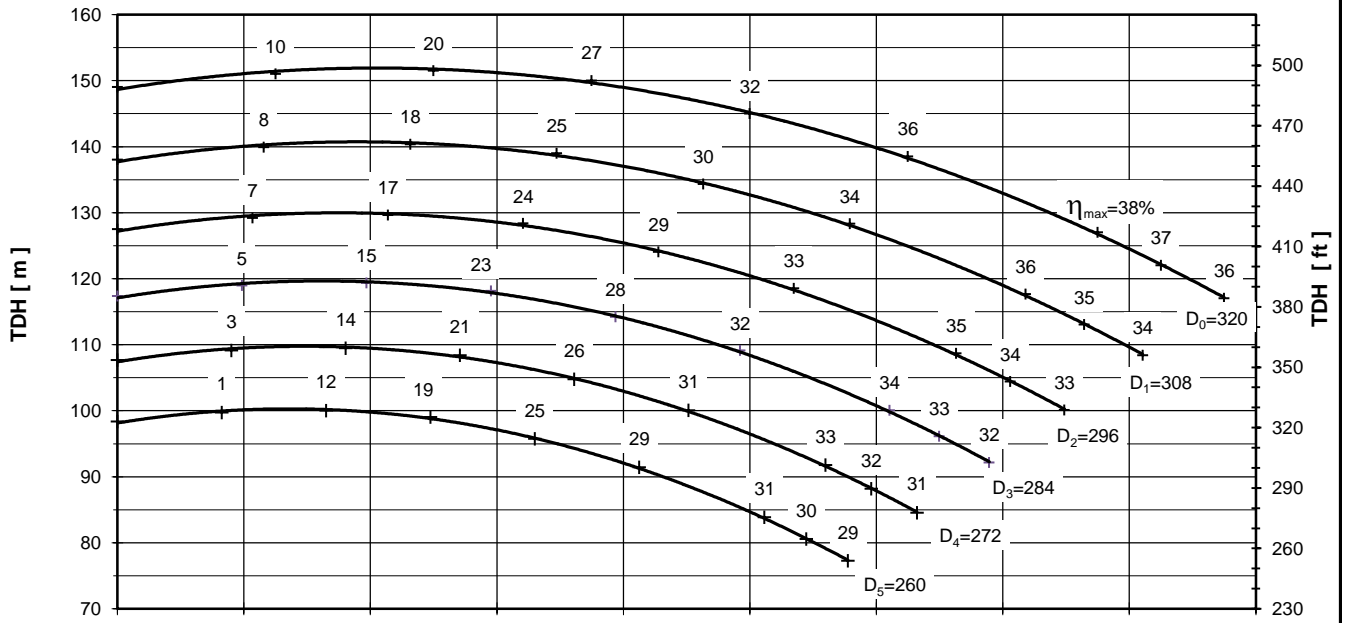

Performance curves are valid for clean cold water-kinematic viscosity 1 [mm²/s], density 1000 [kg/m³]. Methods and tolerances of presented performance curves are in accordance with ISO 9906 - Annex A

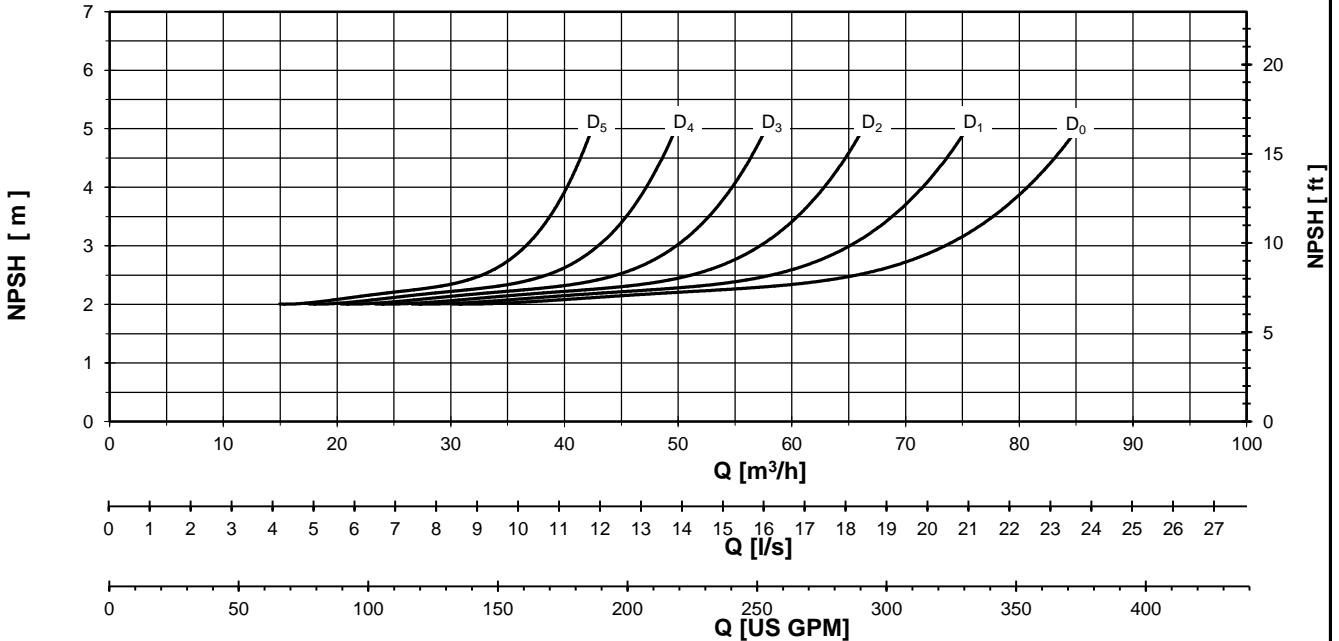
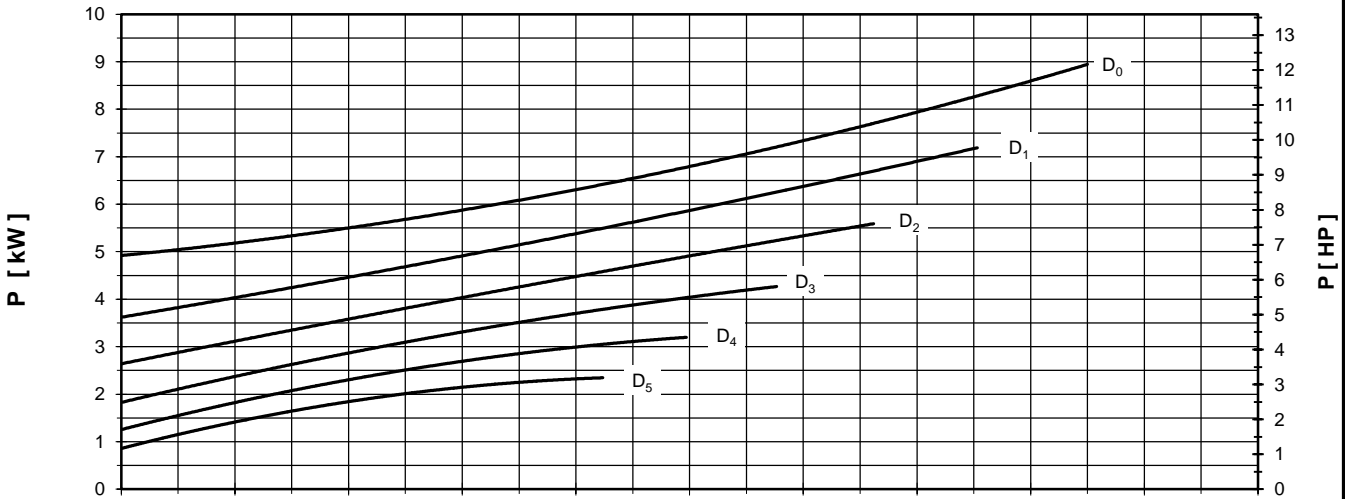
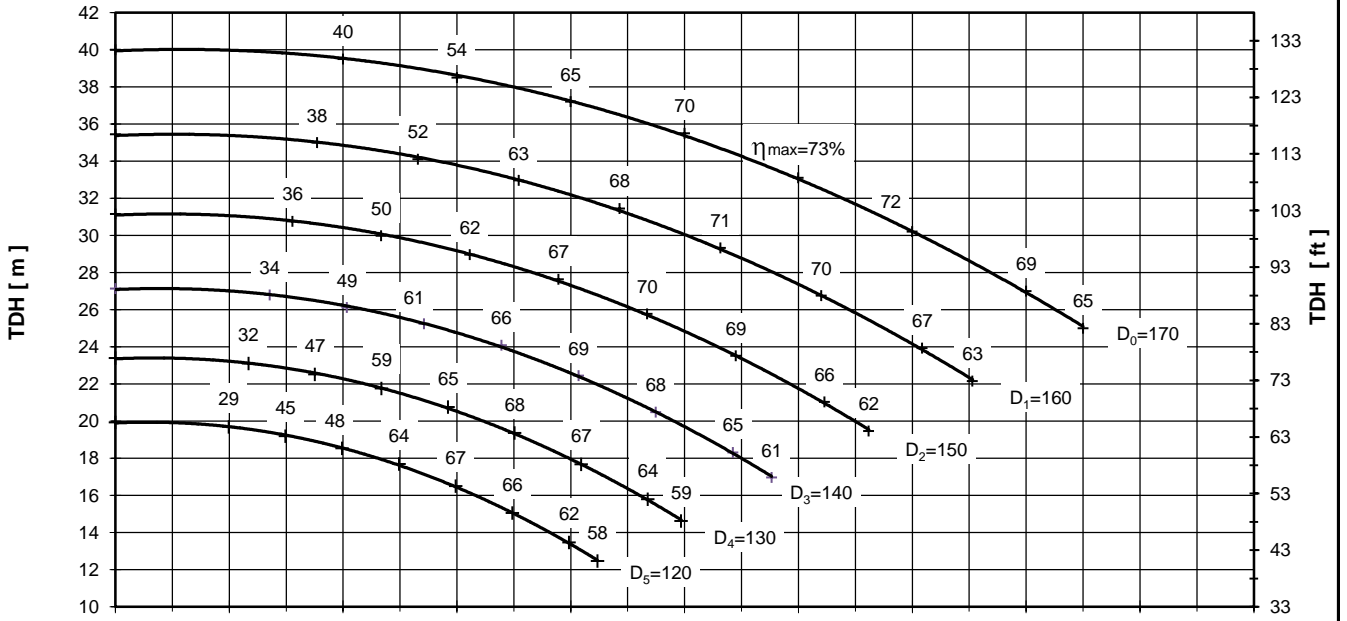

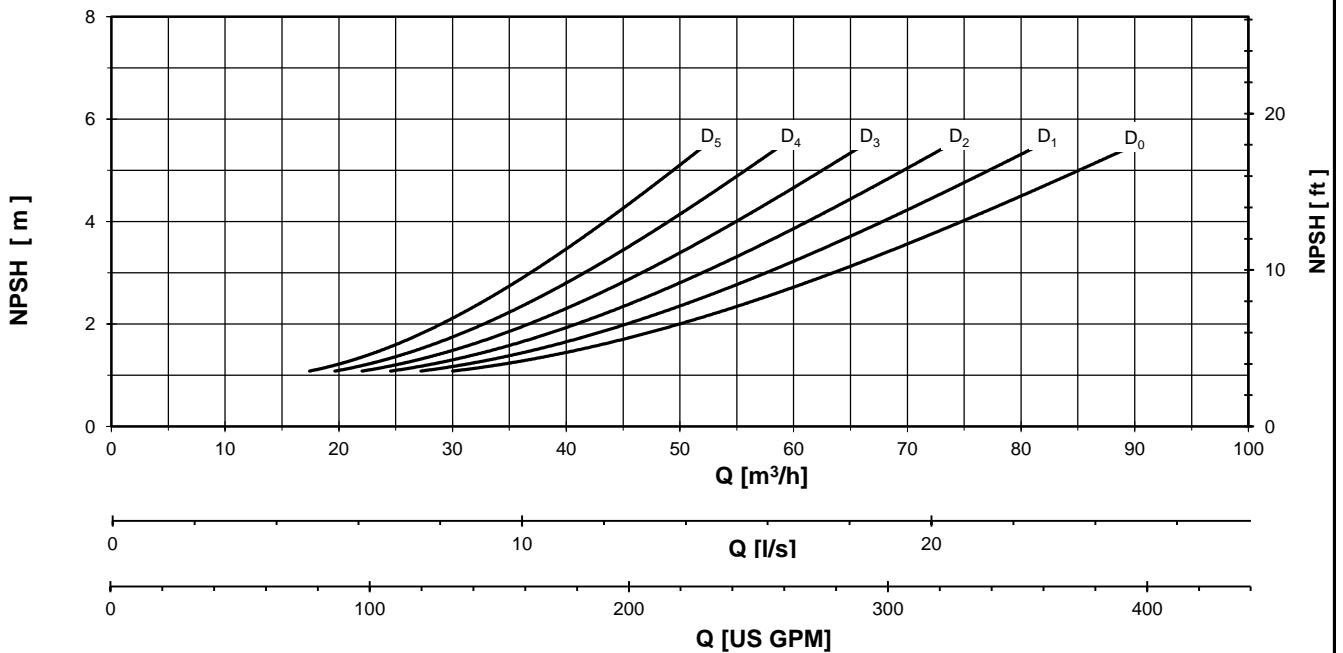
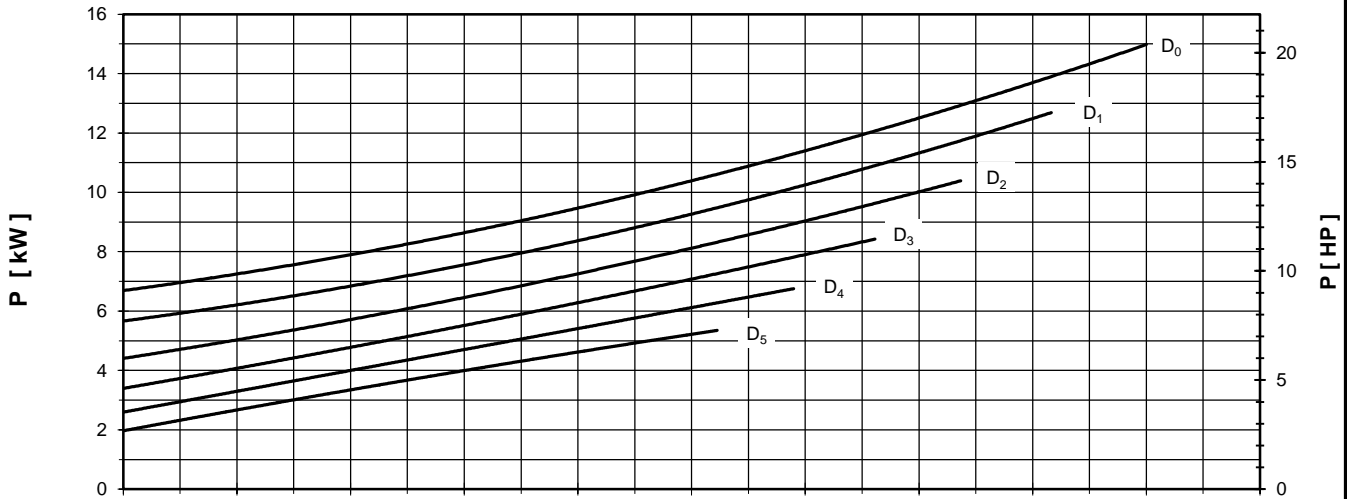
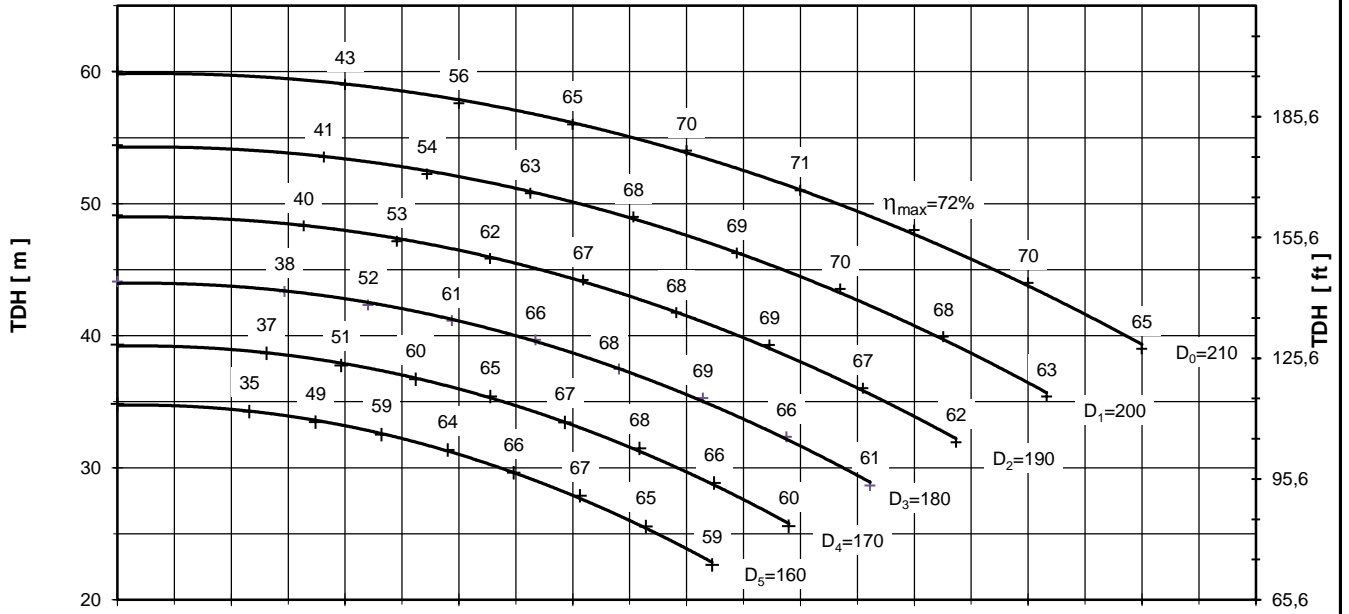

Performance curves are valid for clean cold water-kinematic viscosity 1 [mm²/s], density 1000 [kg/m³]. Methods and tolerances of presented performance curves are in accordance with ISO 9906 - Annex A



PUMP PERFORMANCE CURVES
No. 4HS.0153.05

PUMP TYPE
SCP 50 - 250
2900 [rpm]

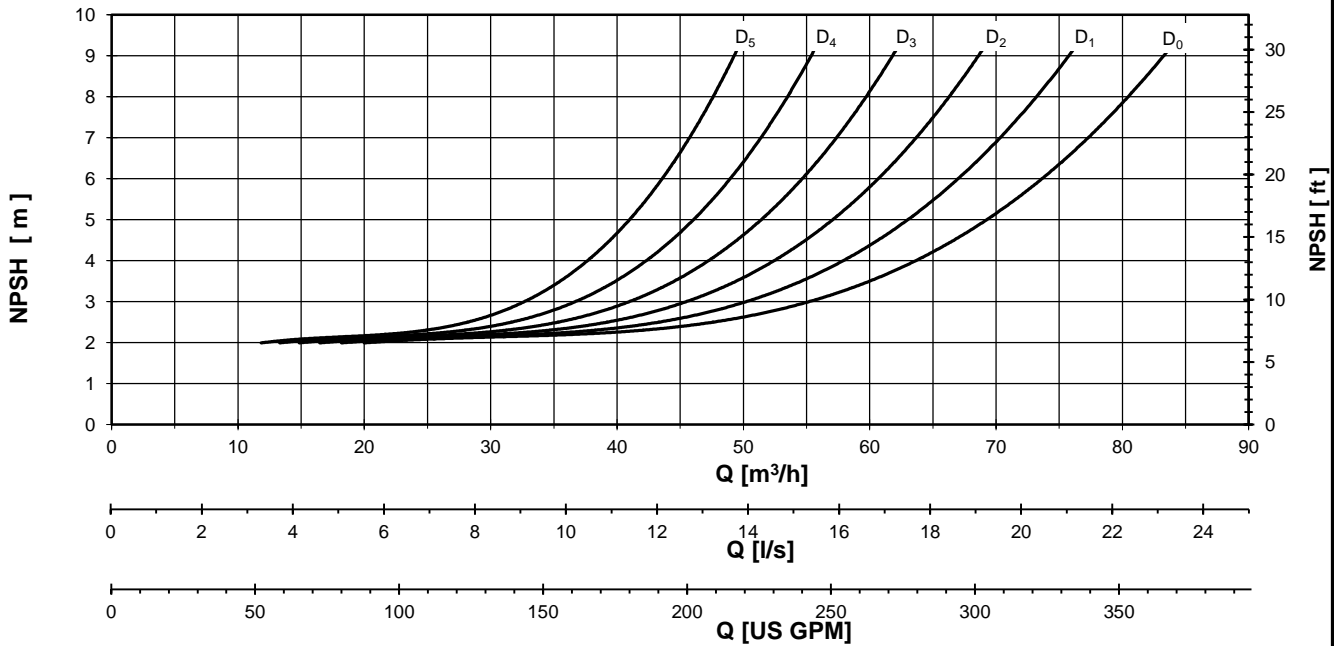
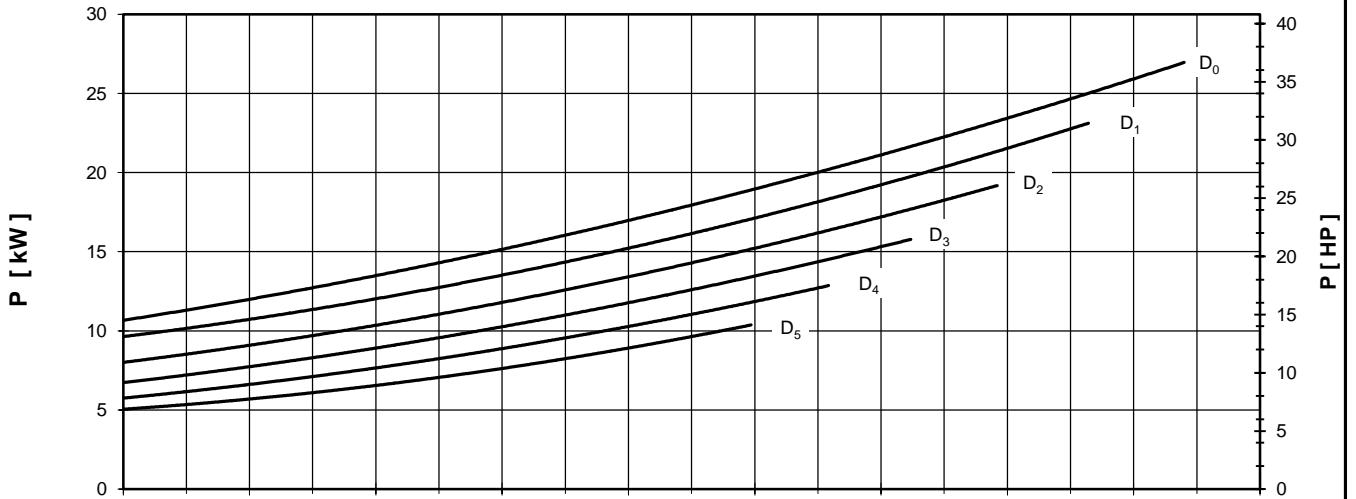
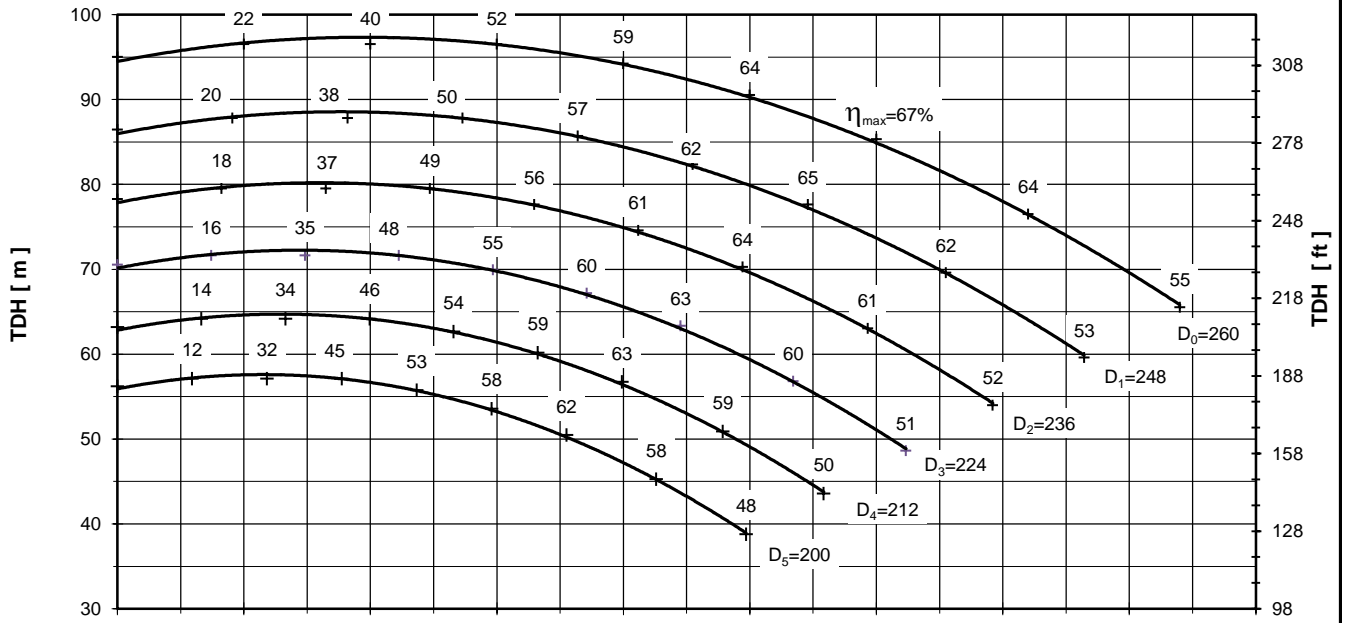

Performance curves are valid for clean cold water-kinematic viscosity 1 [mm²/s], density 1000 [kg/m³]. Methods and tolerances of presented performance curves are in accordance with ISO 9906 - Annex A



PUMP PERFORMANCE CURVES
No. 4HD.0154.05

PUMP TYPE
SCP 50 - 315
2900 [rpm]

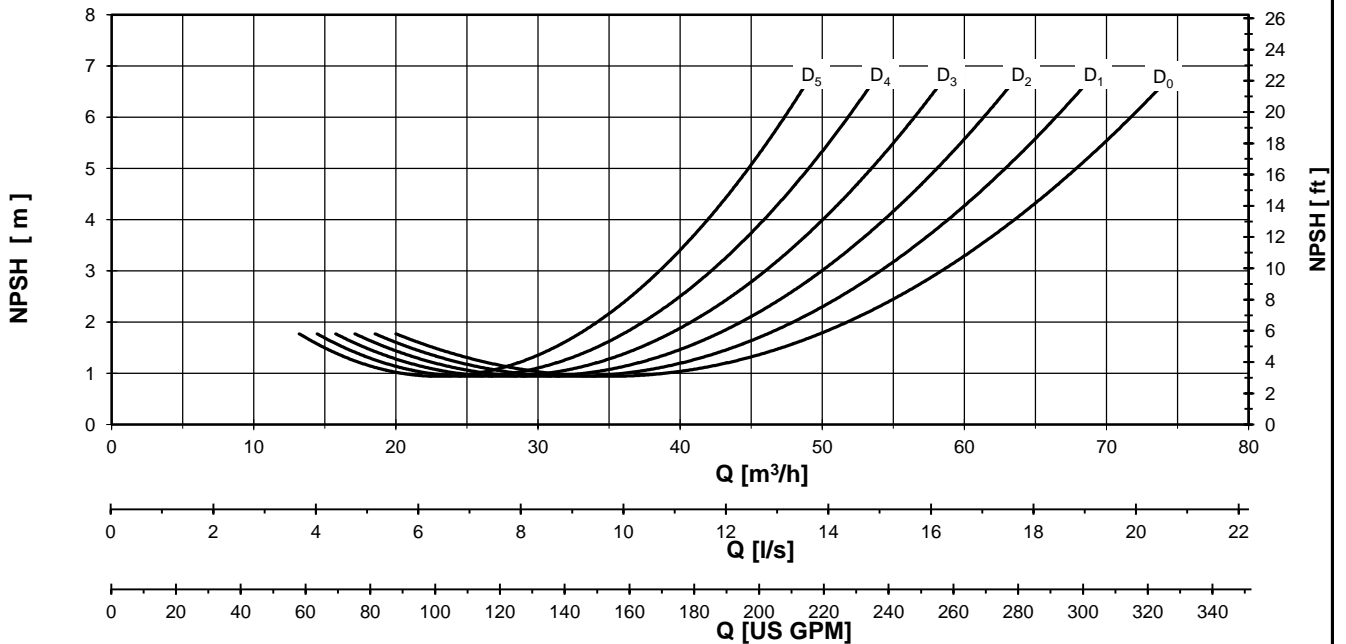
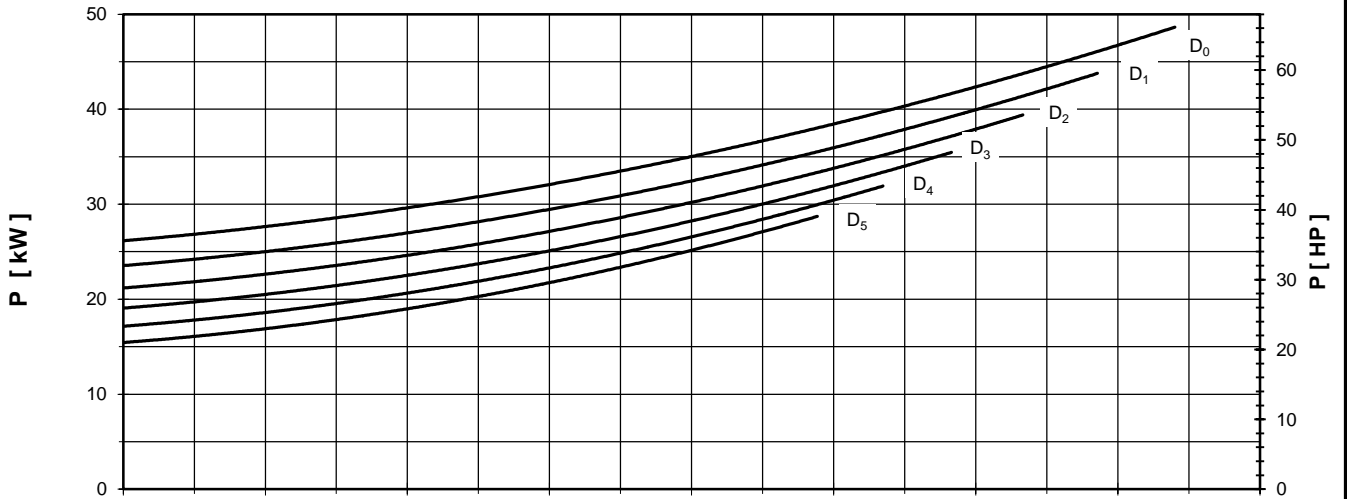
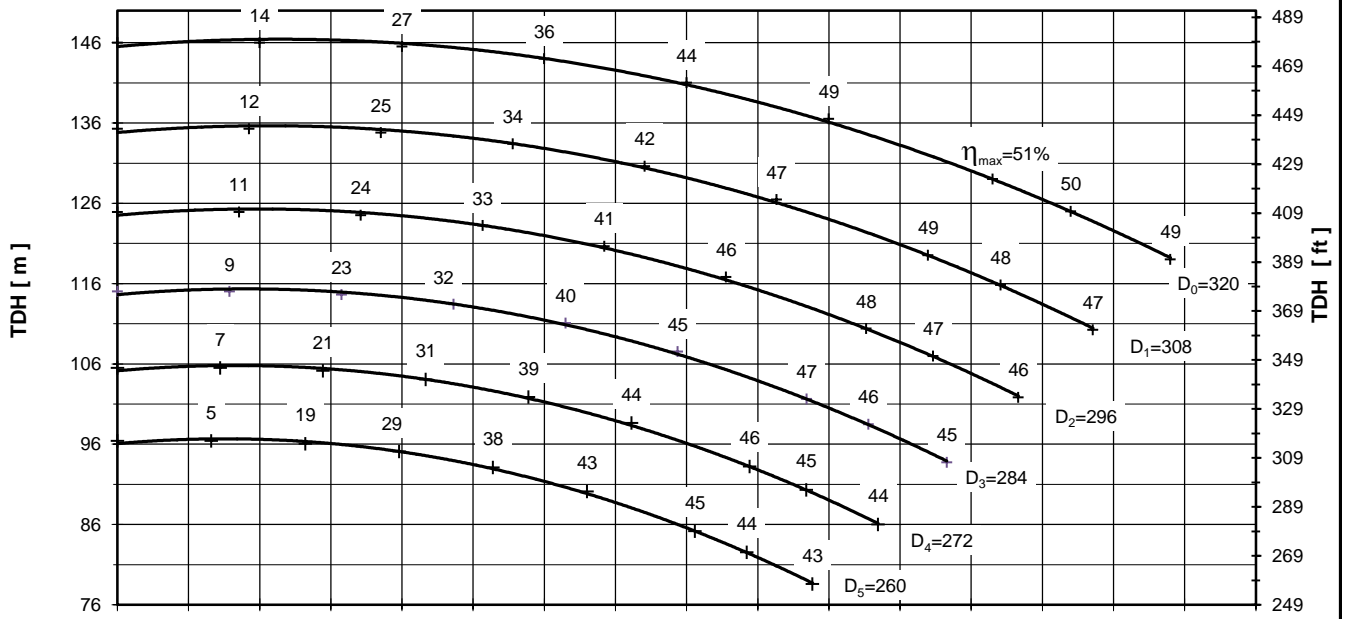

Performance curves are valid for clean cold water-kinematic viscosity 1 [mm²/s], density 1000 [kg/m³]. Methods and tolerances of presented performance curves are in accordance with ISO 9906 - Annex A

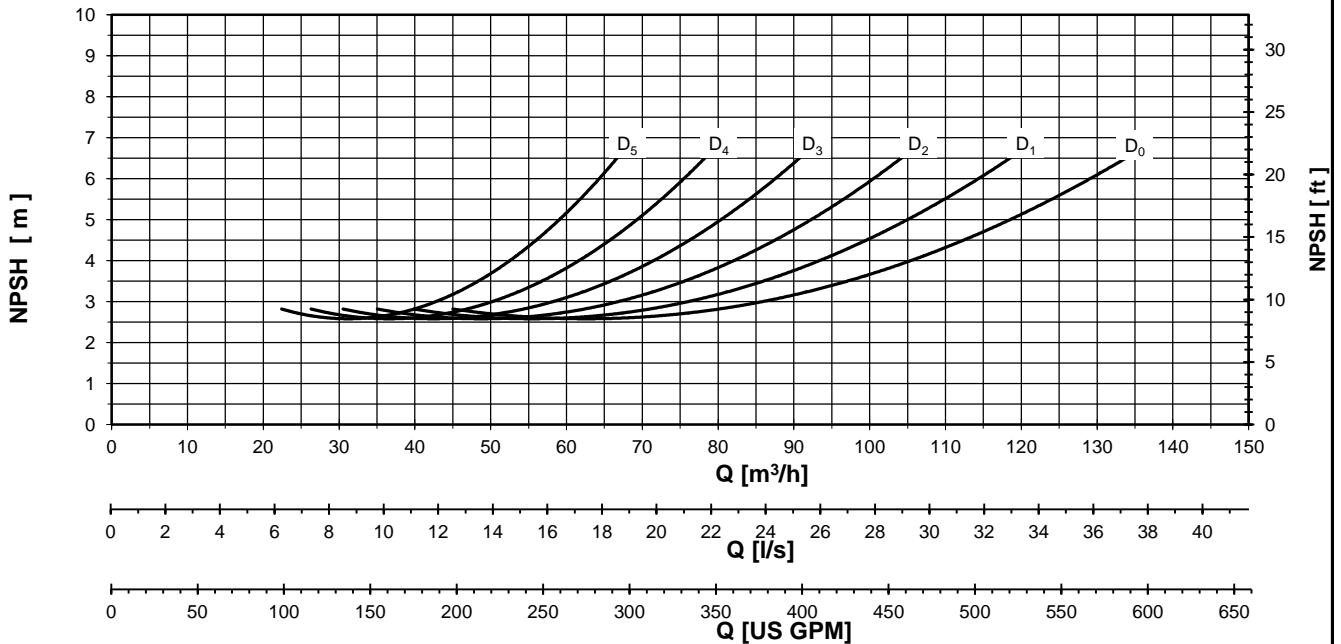
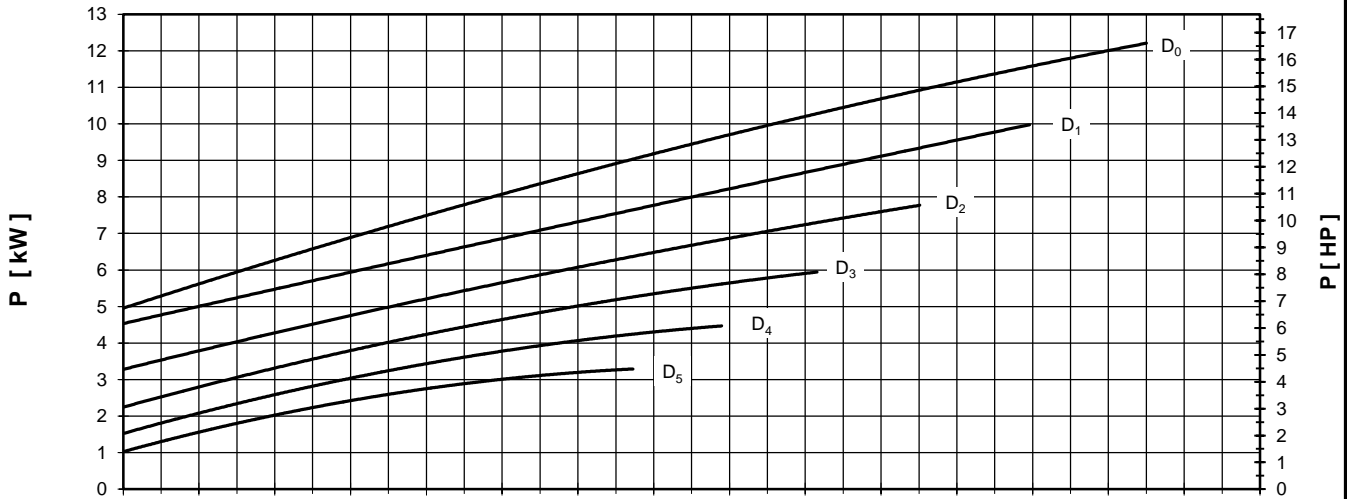
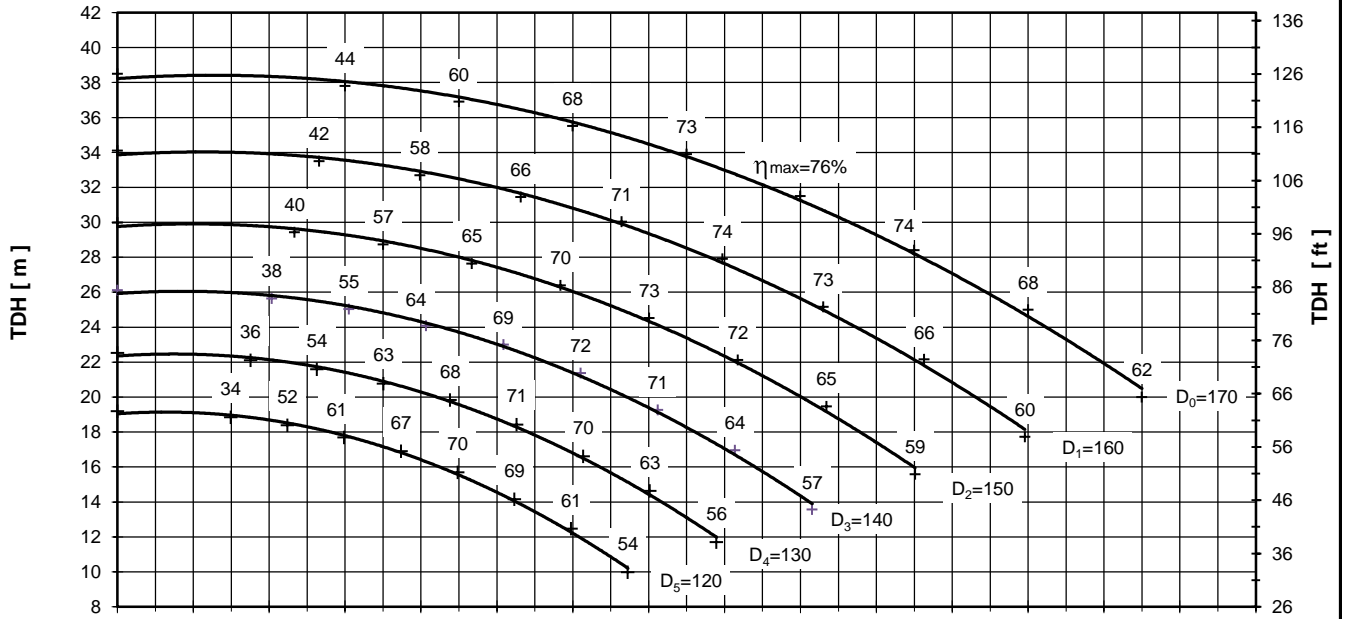

Performance curves are valid for clean cold water-kinematic viscosity 1 [mm²/s], density 1000 [kg/m³]. Methods and tolerances of presented performance curves are in accordance with ISO 9906 - Annex A



PUMP PERFORMANCE CURVES
No. 4HD.0157.05

PUMP TYPE
SCP 65 - 200
2900 [rpm]

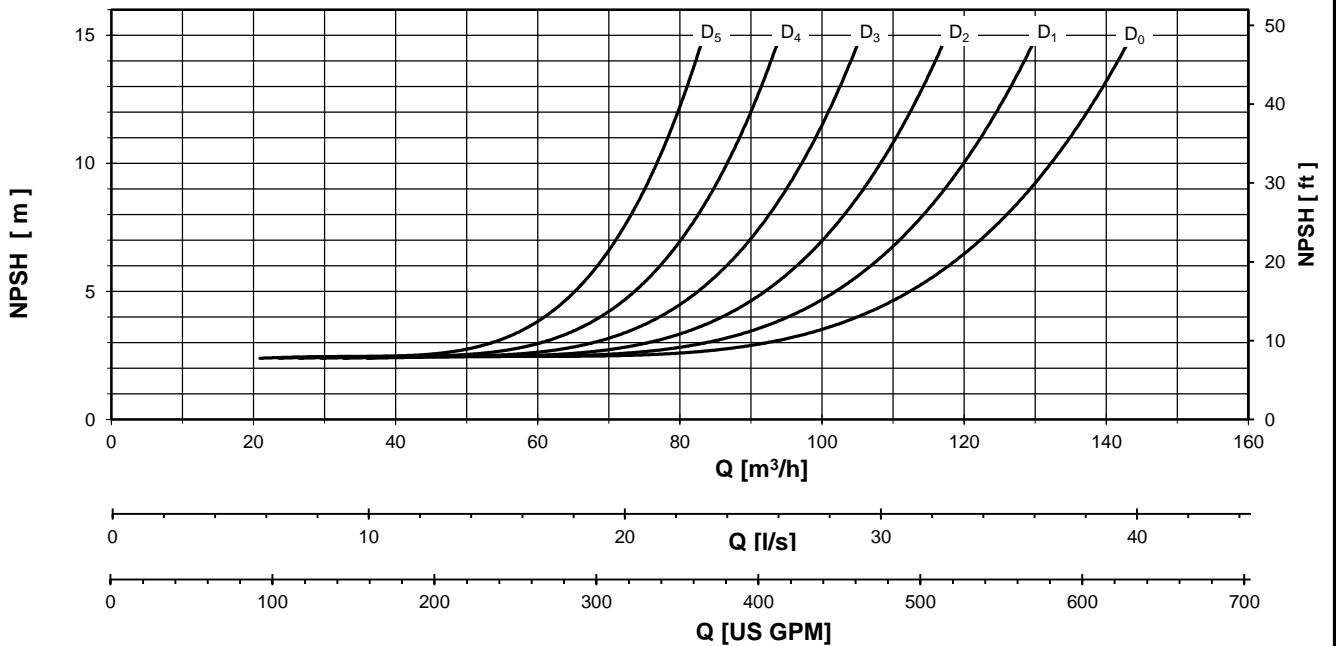
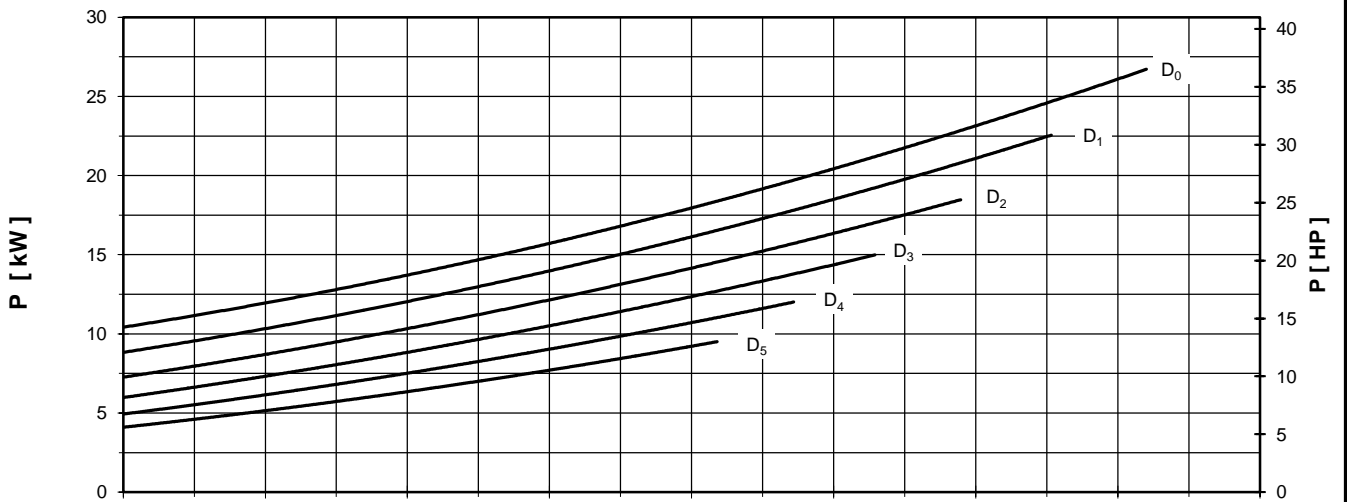
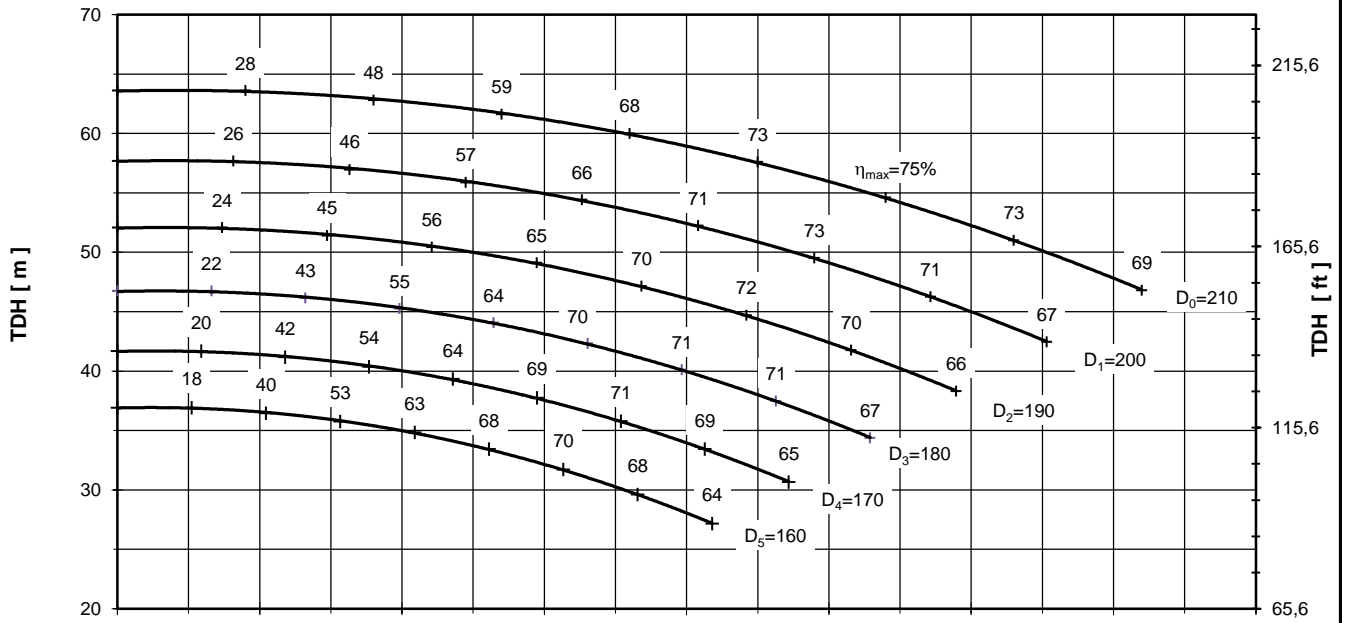

Performance curves are valid for clean cold water-kinematic viscosity 1 [mm²/s], density 1000 [kg/m³]. Methods and tolerances of presented performance curves are in accordance with ISO 9906 - Annex A



PUMP PERFORMANCE CURVES
No. 4HD.0158.05

PUMP TYPE
SCP 65 - 250
2900 [rpm]

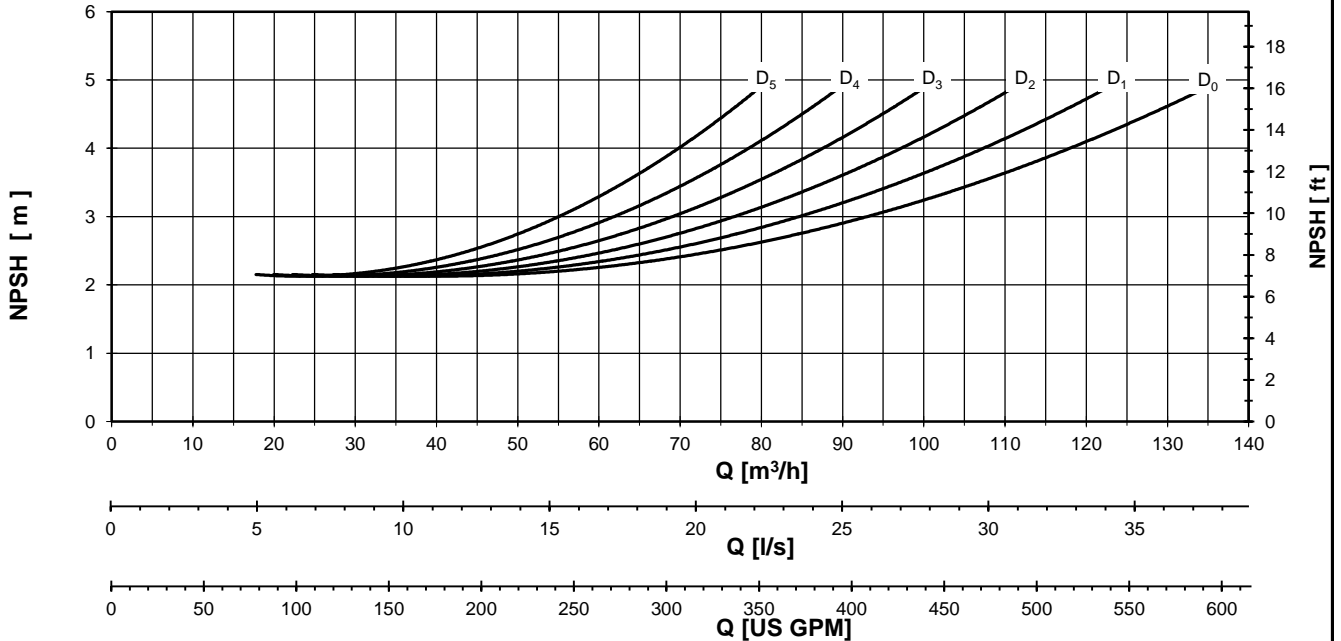
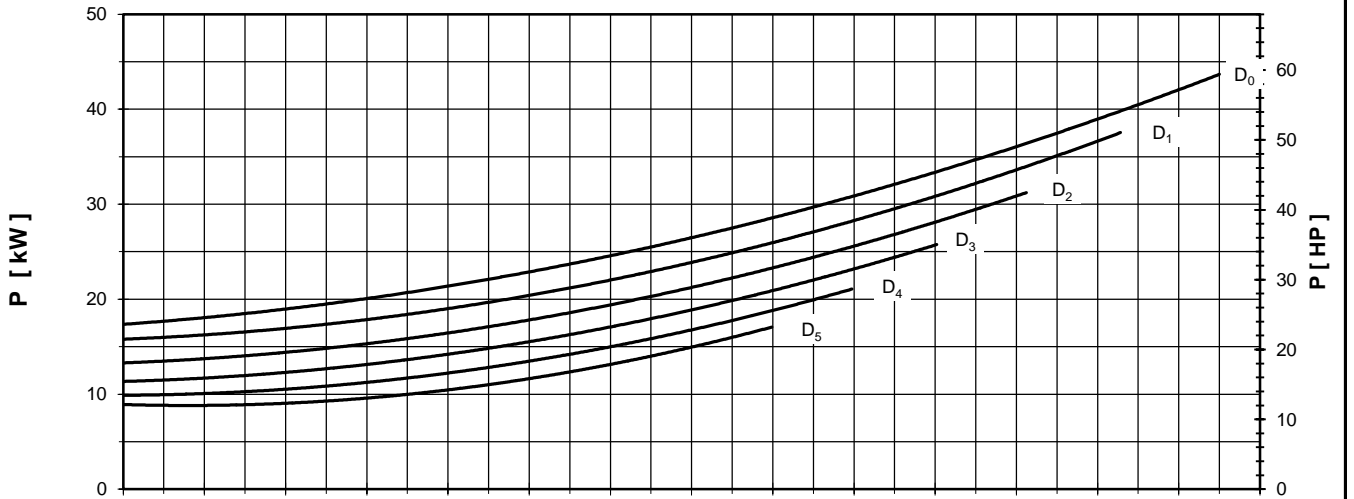
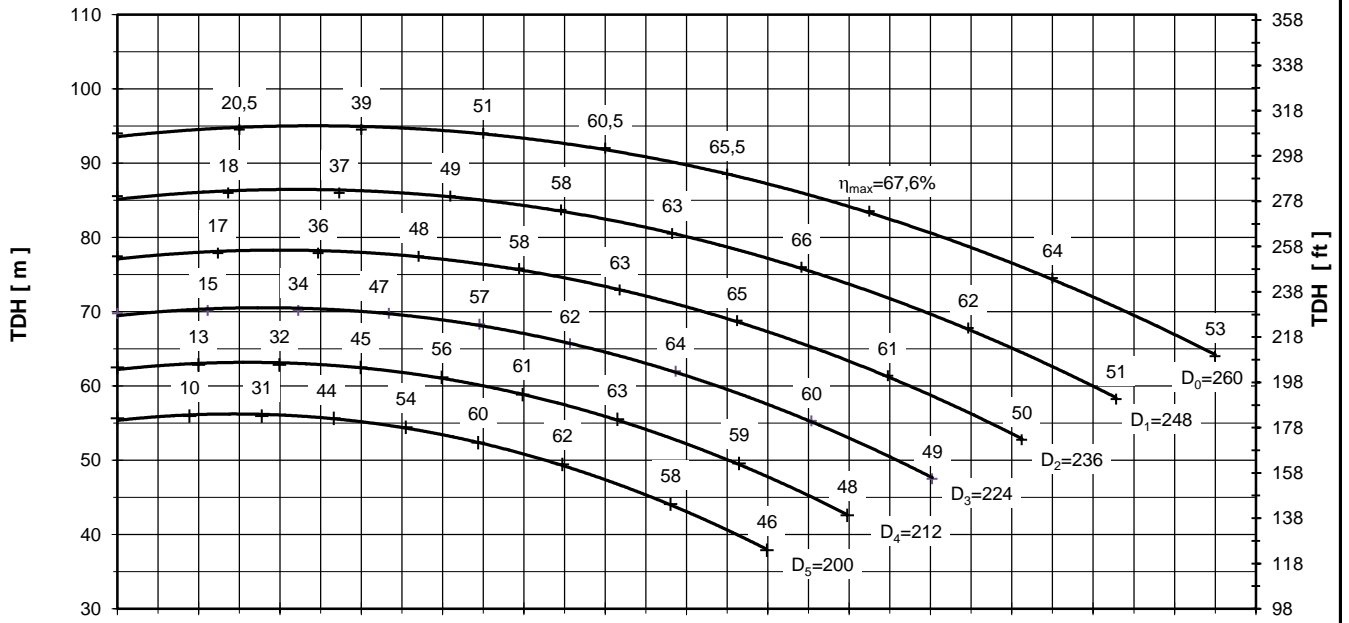

Performance curves are valid for clean cold water-kinematic viscosity 1 [mm²/s], density 1000 [kg/m³]. Methods and tolerances of presented performance curves are in accordance with ISO 9906 - Annex A

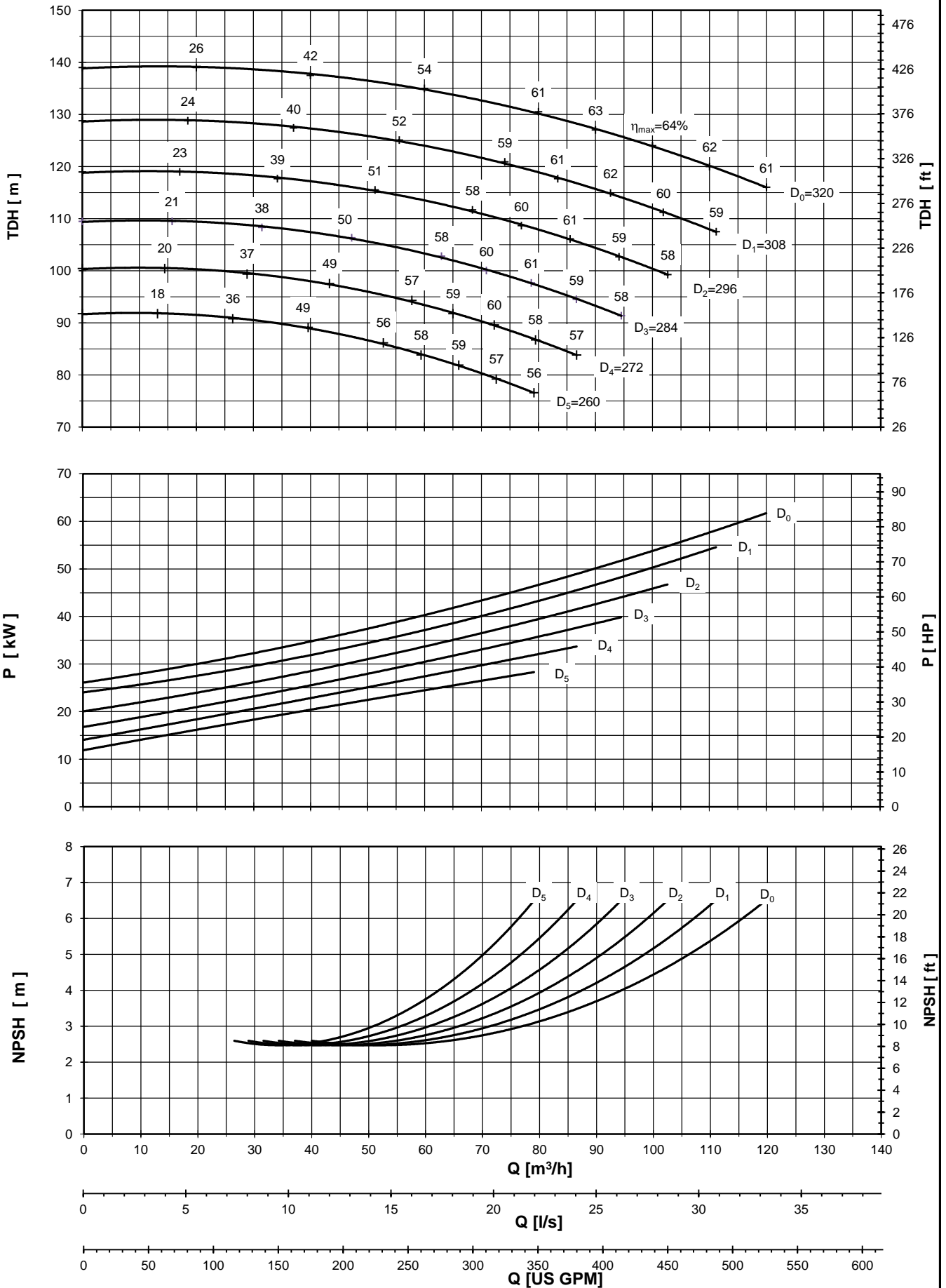

Performance curves are valid for clean cold water-kinematic viscosity 1 [mm²/s], density 1000 [kg/m³]. Methods and tolerances of presented performance curves are in accordance with ISO 9906 - Annex A

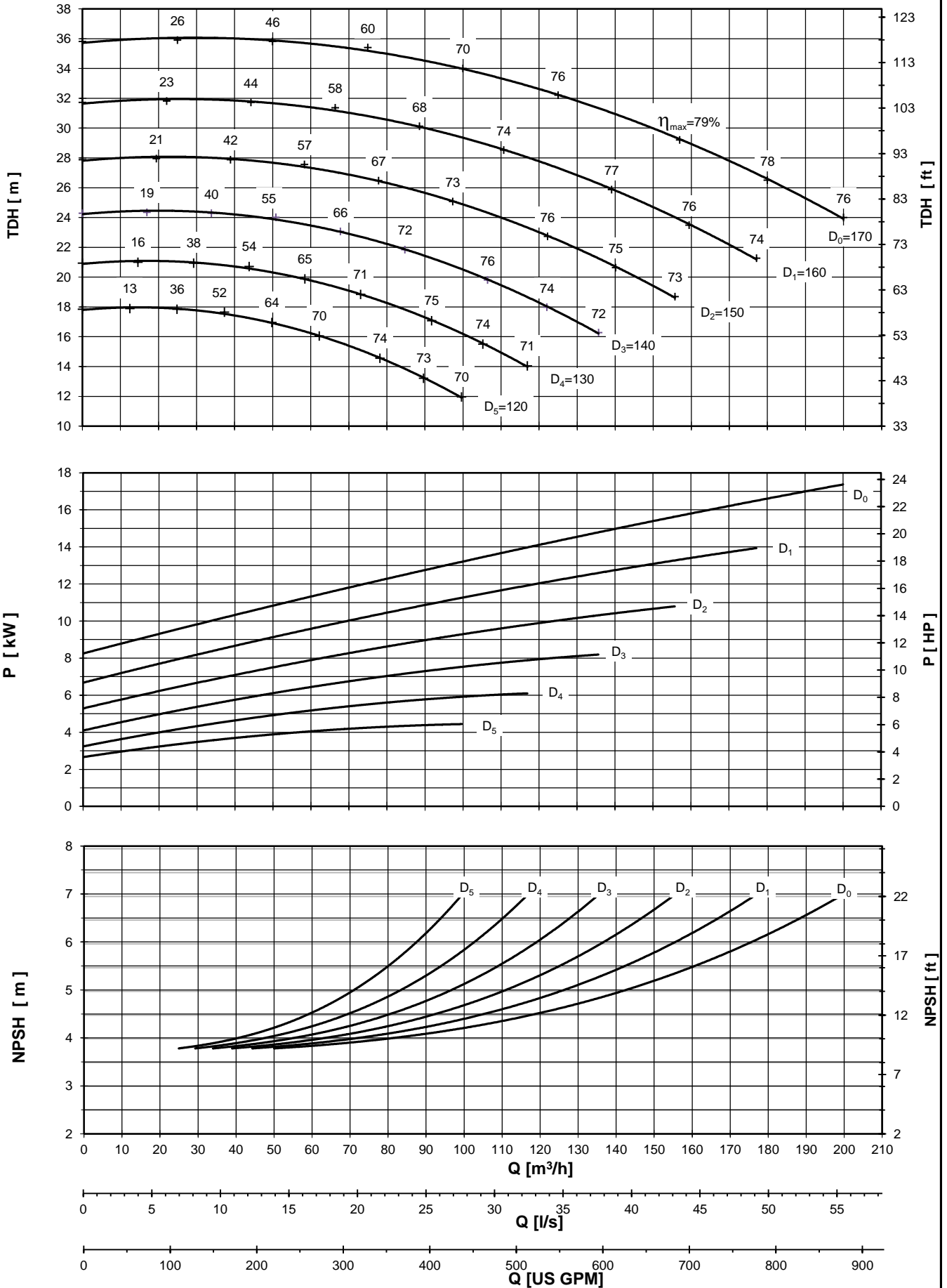

Performance curves are valid for clean cold water-kinematic viscosity 1 [mm²/s], density 1000 [kg/m³]. Methods and tolerances of presented performance curves are in accordance with ISO 9906 - Annex A

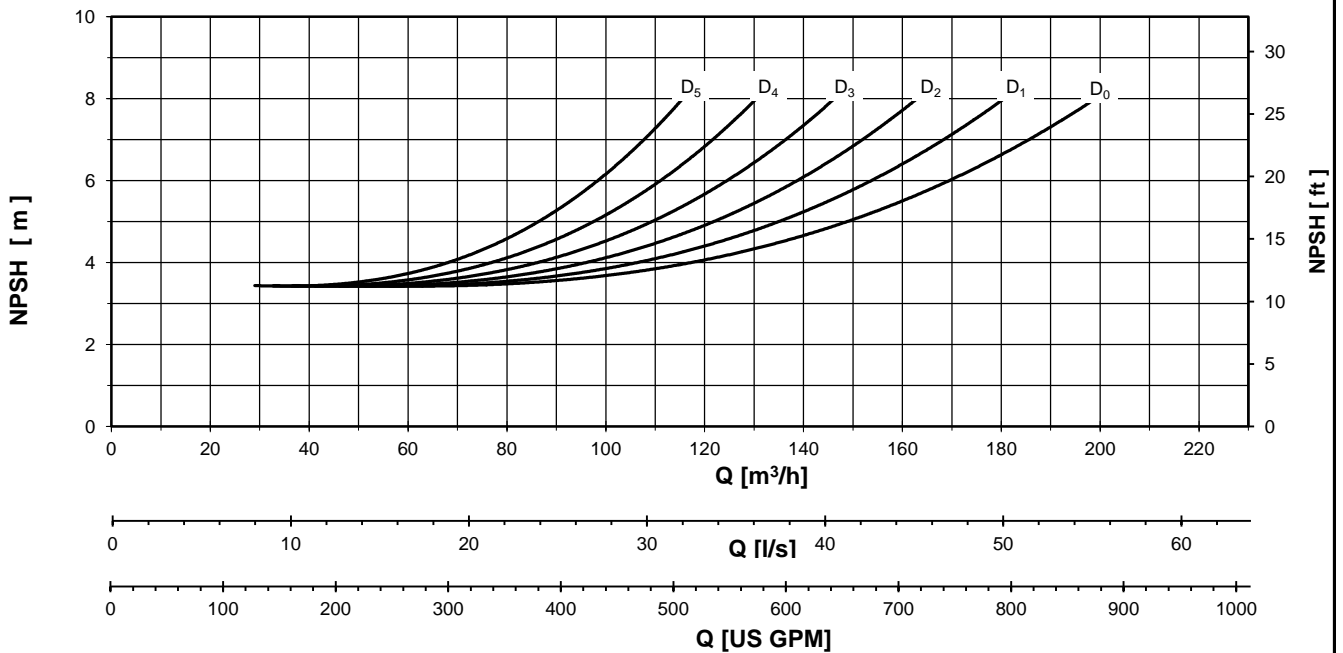
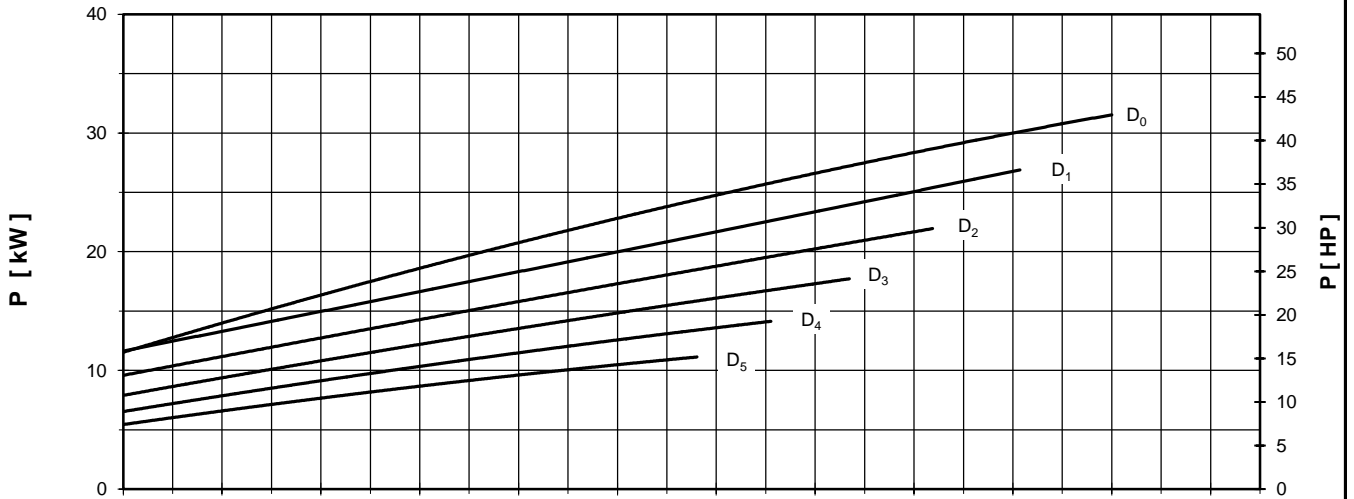
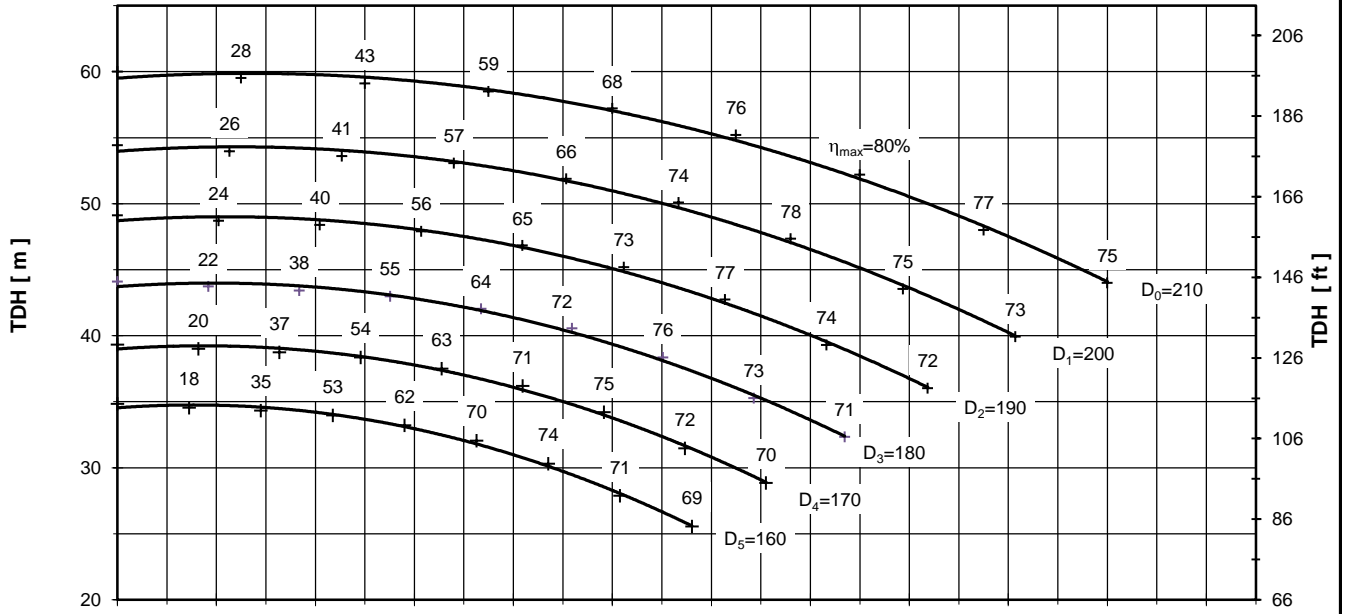

Performance curves are valid for clean cold water-kinematic viscosity 1 [mm²/s], density 1000 [kg/m³]. Methods and tolerances of presented performance curves are in accordance with ISO 9906 - Annex A

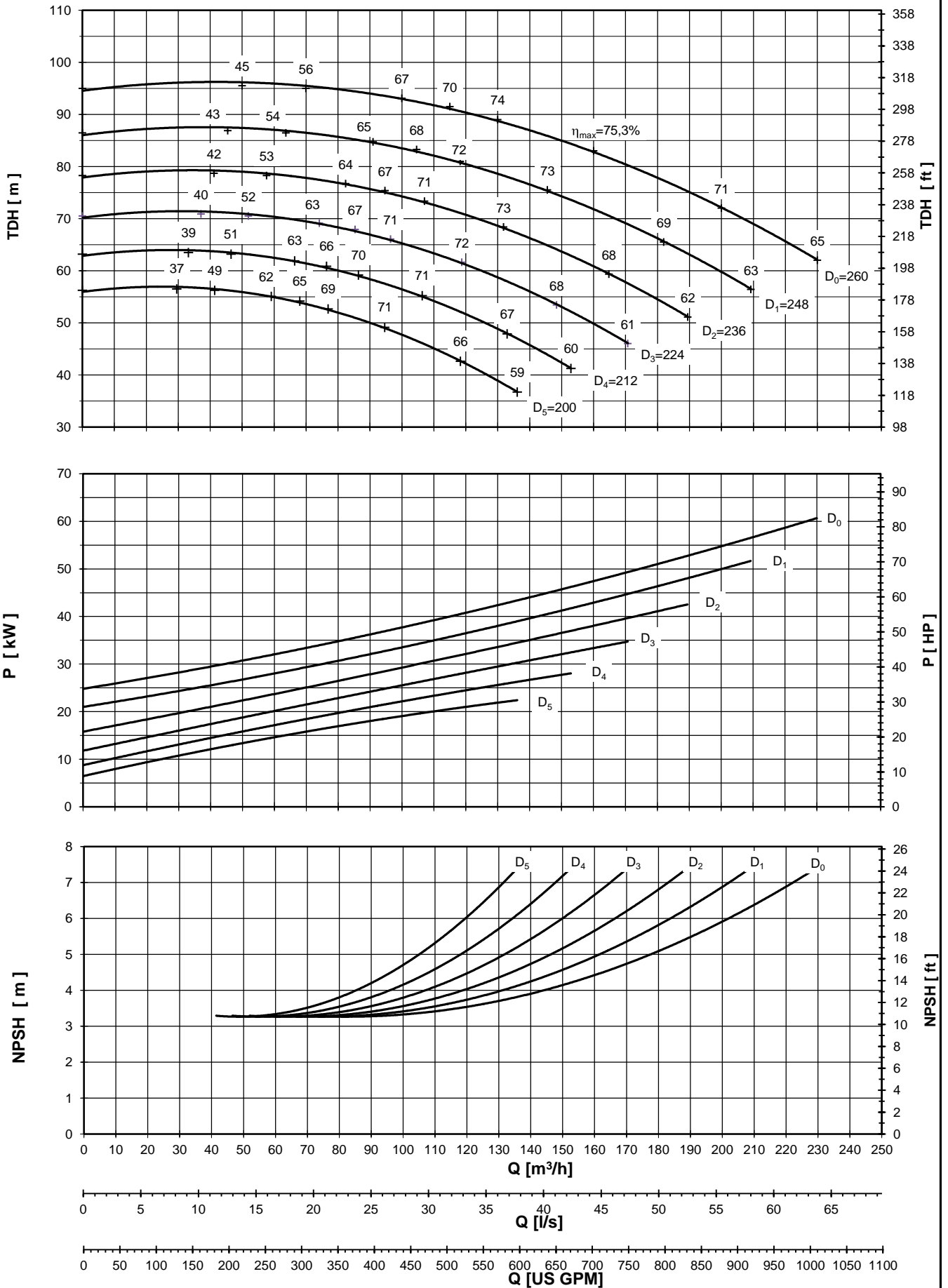

Performance curves are valid for clean cold water-kinematic viscosity 1 [mm²/s], density 1000 [kg/m³]. Methods and tolerances of presented performance curves are in accordance with ISO 9906 - Annex A



PUMP PERFORMANCE CURVES
No. 4HD.0163.05

PUMP TYPE
SCP 80 - 315
2900 [rpm]

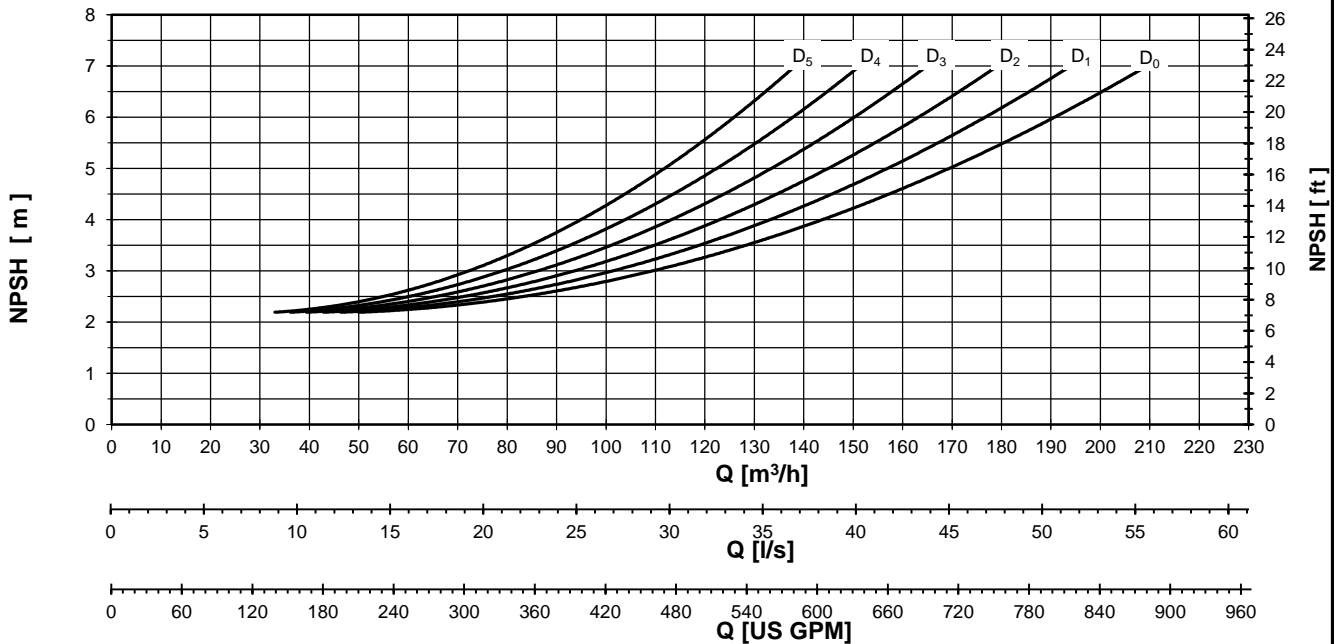
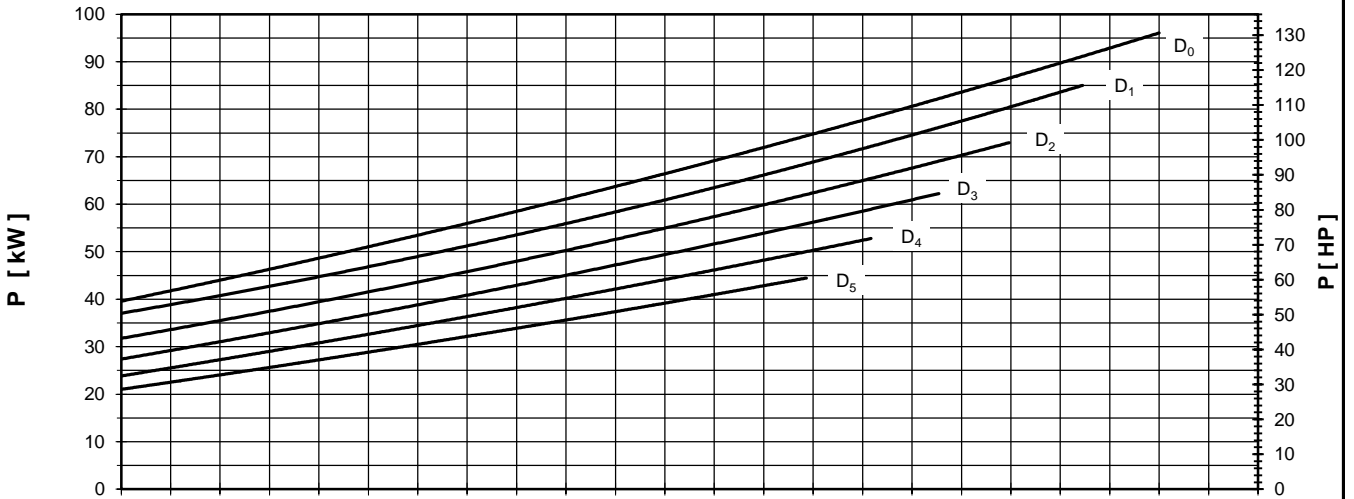
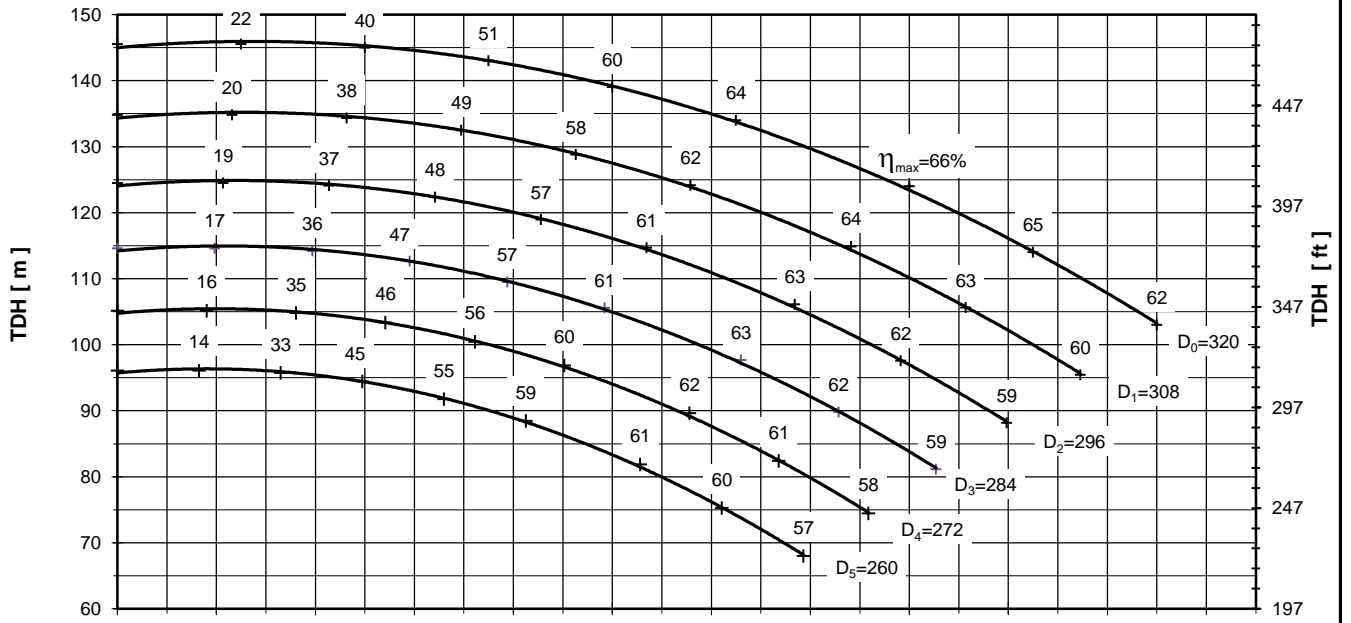

Performance curves are valid for clean cold water-kinematic viscosity 1 [mm²/s], density 1000 [kg/m³]. Methods and tolerances of presented performance curves are in accordance with ISO 9906 - Annex A

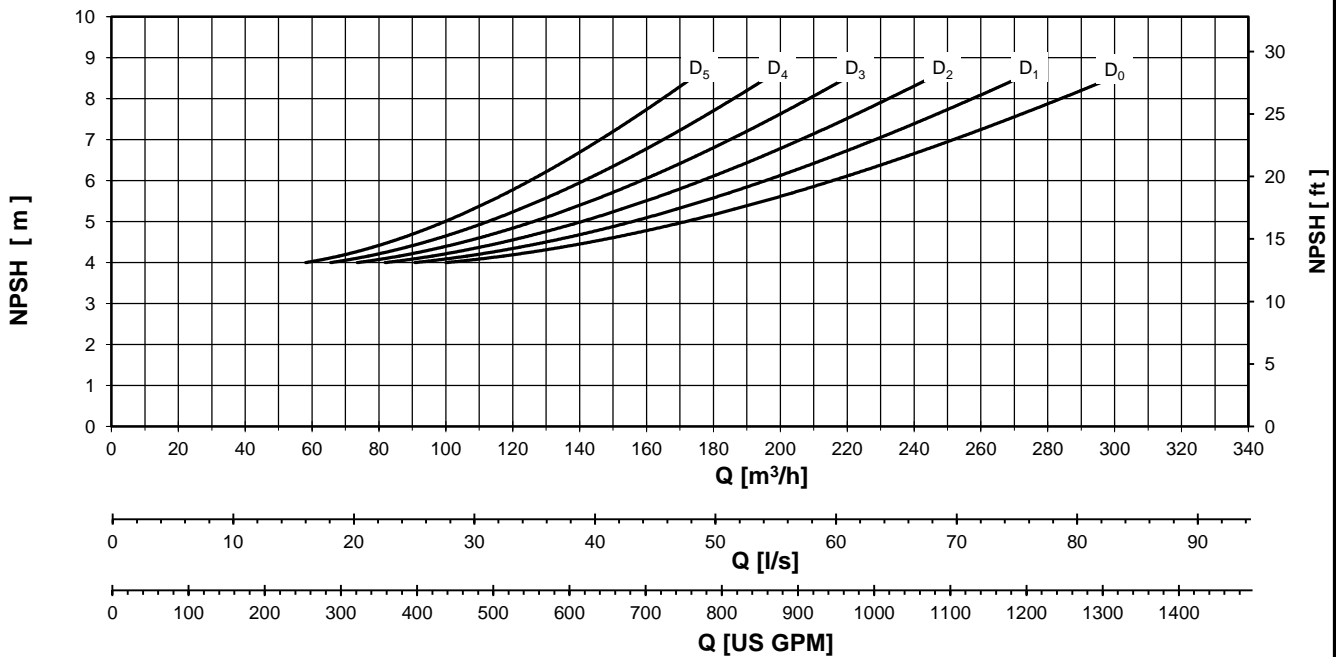
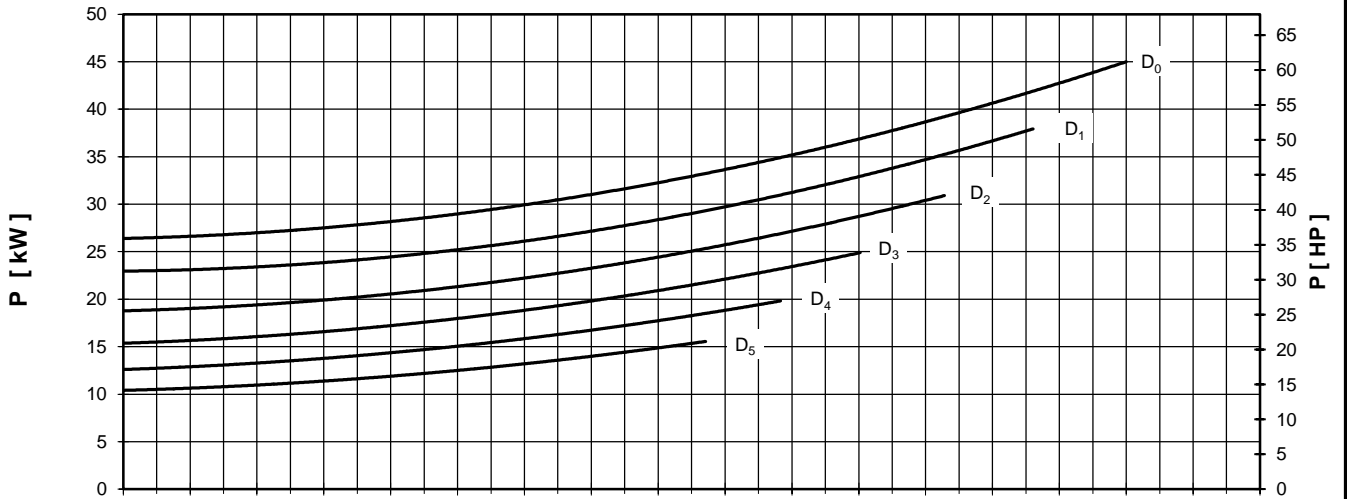
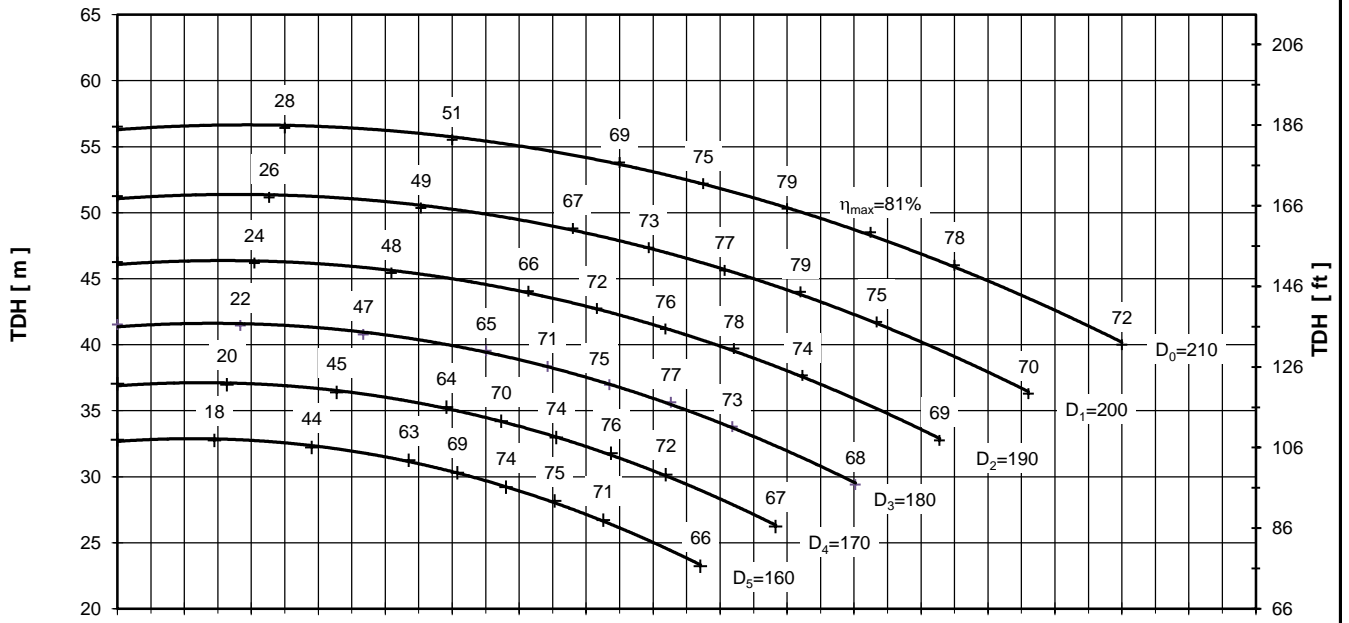

Performance curves are valid for clean cold water-kinematic viscosity 1 [mm²/s], density 1000 [kg/m³]. Methods and tolerances of presented performance curves are in accordance with ISO 9906 - Annex A

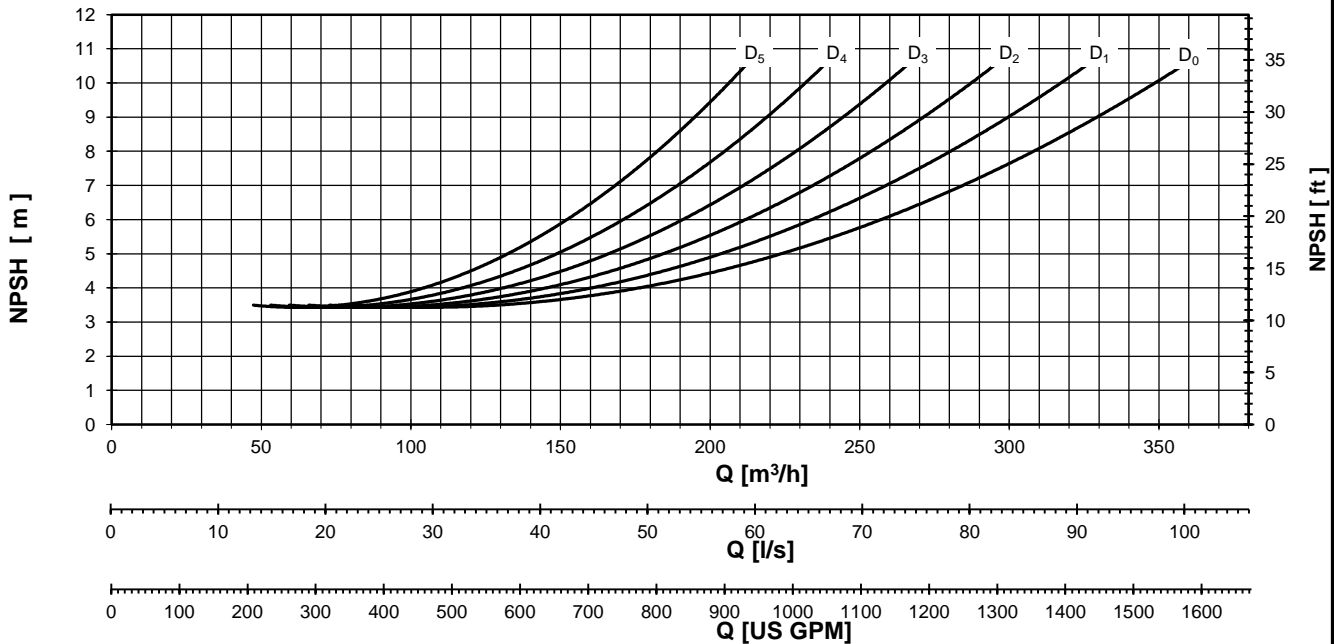
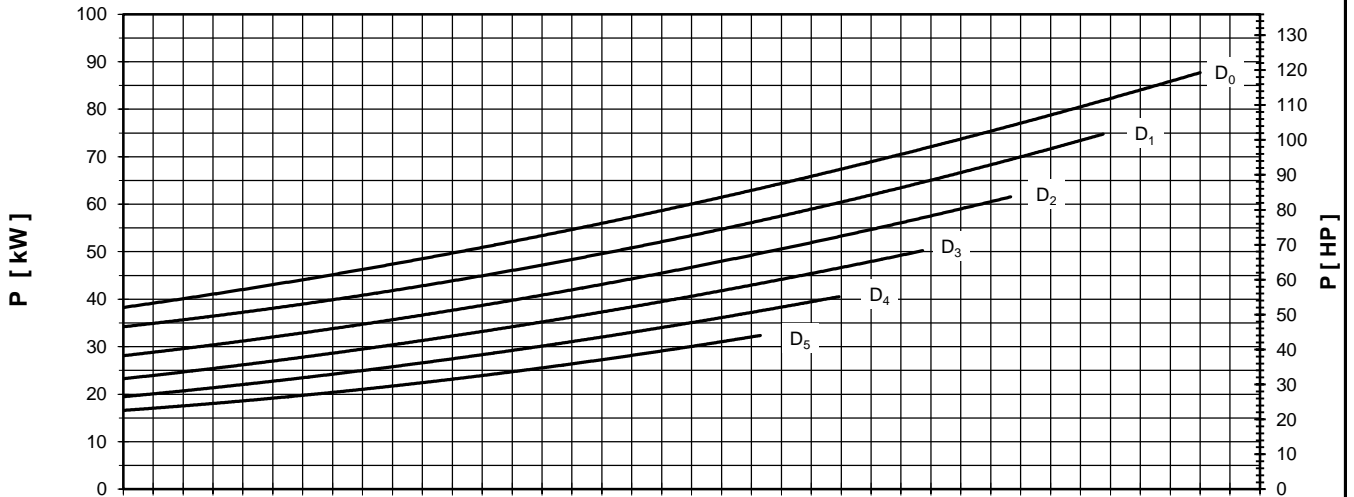
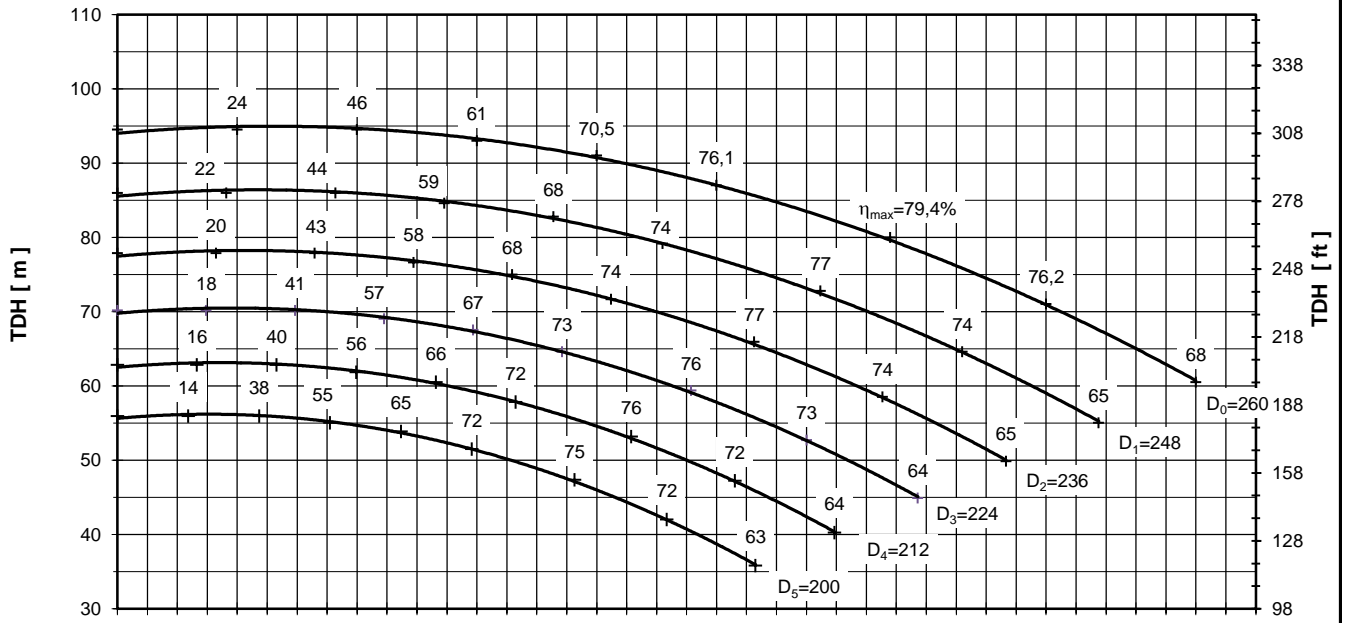



Pero Nakov Str. bb. 1000 Skopje, Republic of Macedonia
Tel. +389 2 2549 817 / 818, Fax. +389 2 2549 833 / 834
www.pumpi.com.mk; e-mail:info@pumpi.com.mk