

NOCCHI Multi EVO

CENTRIFUGAL MULTISTAGE ELECTRIC PUMPS

NEW 2016
PENTAIR



ACS

Prodotto Conforme
D.M. 174/2004

Multi EVO is an horizontal multistage centrifugal electric pump with an axial threaded suction port and a radial threaded discharge port. The innovative, high-efficiency hydraulic system is connected to a latest generation motor with mechanical seal.

All models are certified for use with household water (ACS and DM174)

ADVANTAGES

Electric pumps in the Multi EVO series offer the following advantages:

- Low energy consumption thanks to high-efficiency hydraulic system.
- High performance
- High-level reliability - thanks to the resistant and innovative design
- Silent operation - improved user comfort thanks to its silent operation
- Compact form
- Wide range



SPECIFICATIONS:

PUMP

- Hydraulic performance conforms to ISO 9906:2012 - Grade 3B
- Type of liquid: clean water with no suspended solids or abrasive material
- Maximum liquid temperature 50°C
- Maximum operating pressure 8 bar
- Maximum recommended suction height 6m with foot valve

MOTOR

- Enclosed, air ventilated (TEFC)
- 2 poles, 50 Hz (n=2850 rpm)
- IE3 three-phase AC (≥ 0.75 kW)
- Protection class: IP55
- Insulation class: F
- Maximum room temperature 40°C
- Single phase power supply with permanently inserted condenser and thermal protection incorporated into motor winding



APPLICATIONS

- Pressurization and supply
- Irrigation
- Re-utilization of rainwater
- Cleaning systems



NOCCHI Multi EVO

CENTRIFUGAL MULTISTAGE ELECTRIC PUMPS

DESIGN FEATURES

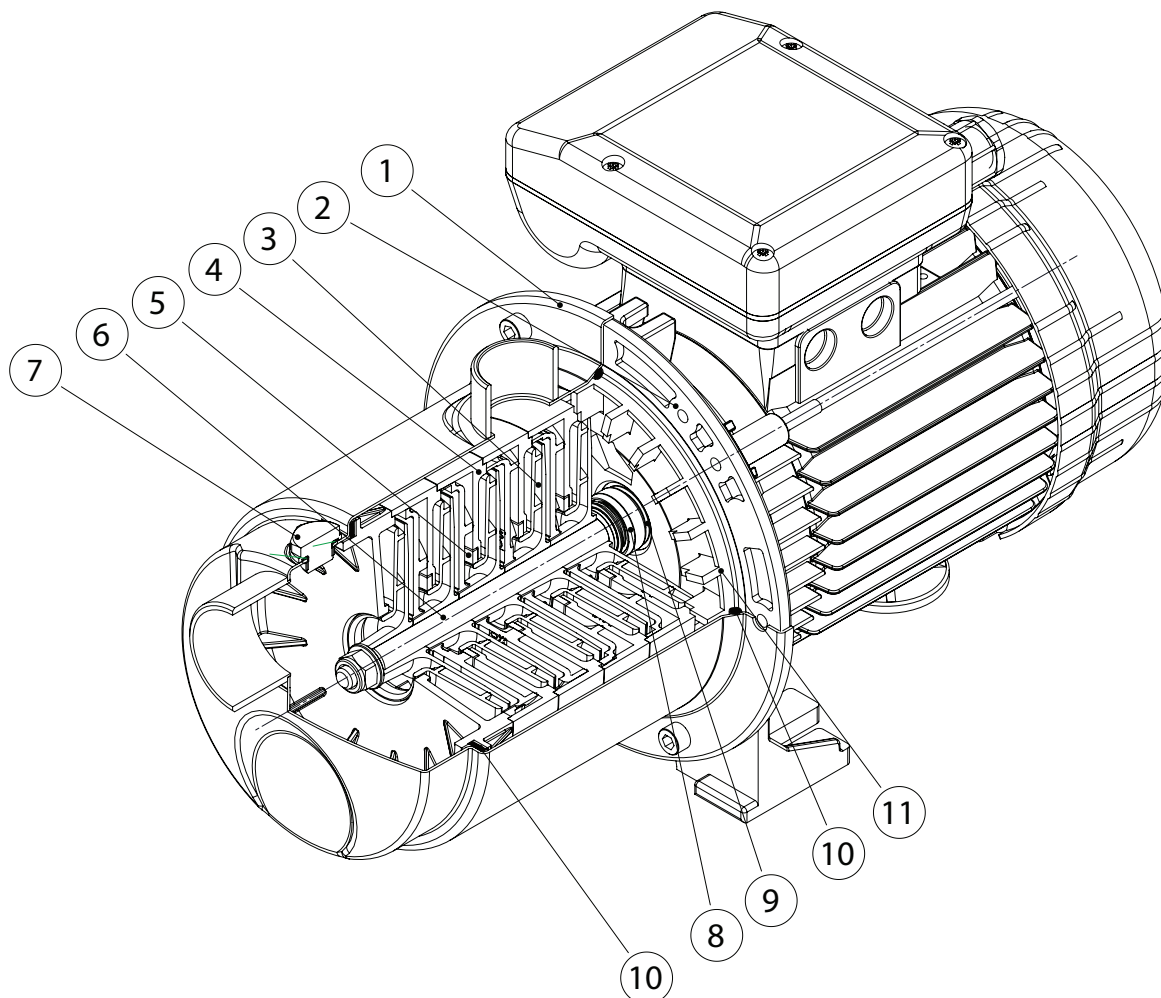

TABLE OF MATERIALS

Ref.	Component	Material
1	Pump body	Stainless steel Europe: EN10088-1 X5CrNi18-10 (1.4301) USA: AISI 304
2	Motor casing	Die-cast aluminium
3	Impeller	Fibreglass reinforced PPO
4	Diffuser	Fibreglass reinforced PPO
5	Wear ring	PTFE
6	Shaft (hydraulic part)	Stainless steel Europe: EN10088-1 X5CrNi18-10 (1.4301) USA: AISI 304
7	Inlet / outlet caps	Stainless steel Europe: EN10088-1 X8CrNiS18-9 (1.4305) USA: AISI 303
8	Mechanical seal	Carbon graphite / NBR / SS Europe: EN10088-1 X5CrNi18-10 (1.4301) USA: AISI 304
9	Counterface	Ceramic / NBR
10	Gaskets	NBR 70 Shore A
11	Seal holder plate	Fibreglass reinforced PPO

NOCCHI Multi EVO 3

CENTRIFUGAL MULTISTAGE ELECTRIC PUMPS

HYDRAULIC PERFORMANCE

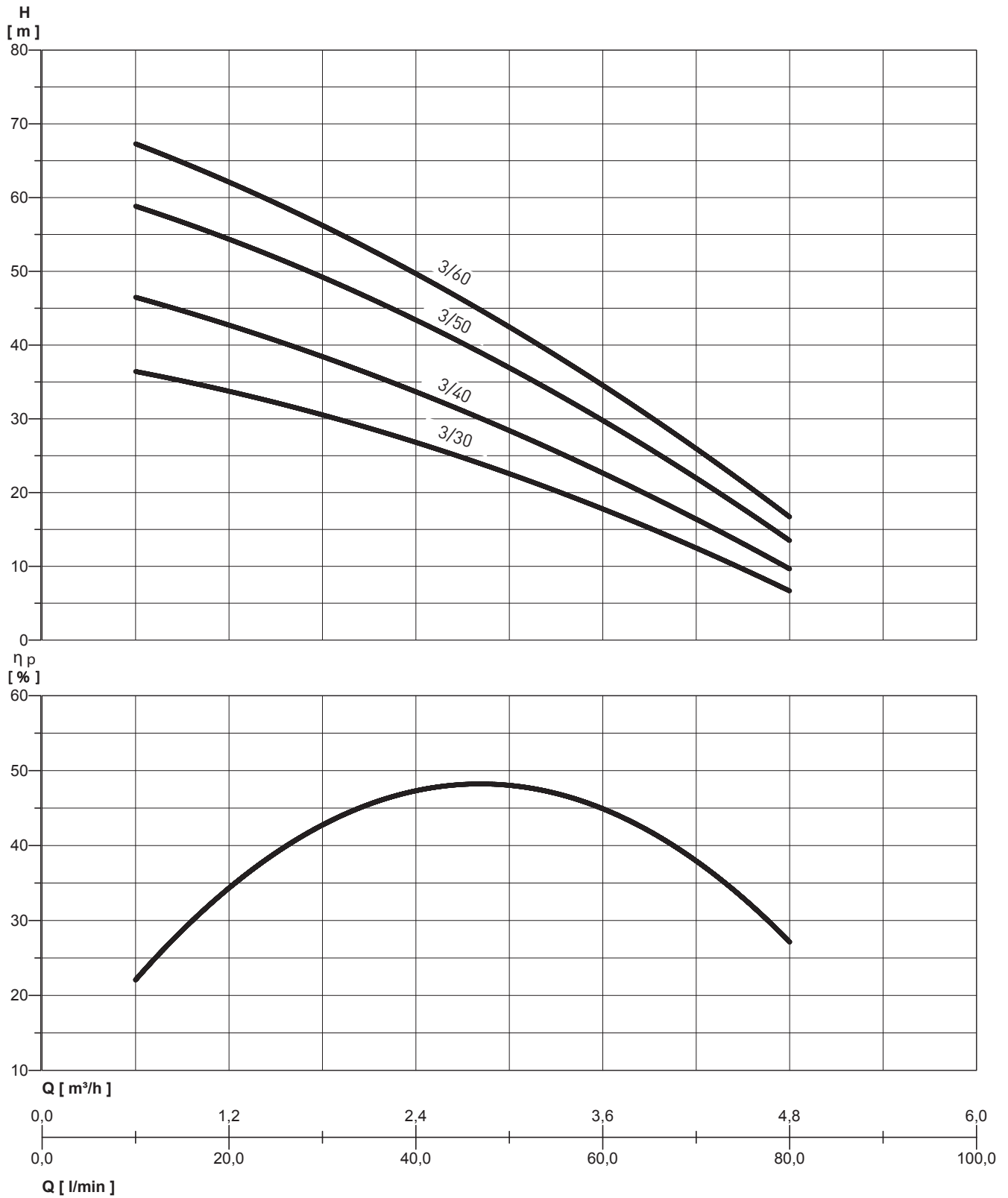

NOCCHI Multi EVO 3

CENTRIFUGAL MULTISTAGE ELECTRIC PUMPS

PERFORMANCE TABLE

MODEL	Nominal power (P2)		Absorbed power (P1)		Voltage (V)	In (A)	μF	Q	Total head in metres water column						
	HP	kW	HP	kW					10	20	30	40	50	60	80
								l/min	0,6	1,2	1,8	2,4	3	3,6	4,8
								m ³ /h							
Multi EVO 3-30 M	0,54	0,4	0,87	0,65	1 ~ 230	2,95	12,5		36	34	31	27	22,5	17	7
Multi EVO 3-30 T	0,54	0,4	0,87	0,65	3 ~ 230/400	2,3 / 1,3	---								
Multi EVO 3-40 M	0,74	0,55	1,1	0,8	1 ~ 230	3,7	12,5		46	43	39	34	28	22	10
Multi EVO 3-40 T	0,71	0,53	1,05	0,78	3 ~ 230/400	2,7 / 1,55	---								
Multi EVO 3-50 M	0,94	0,7	1,34	1	1 ~ 230	4,4	16		58	55	50	44	36	29	14
Multi EVO 3-50 T	0,94	0,7	1,34	1	3 ~ 230/400	3,3 / 1,9	---								
Multi EVO 3-60 M	1,2	0,9	1,68	1,25	1 ~ 230	5,8	20		67	62	57	50	42	34	17
Multi EVO 3-60 T	1,1	0,82	1,57	1,17	3 ~ 230/400	3,5 / 2	---								

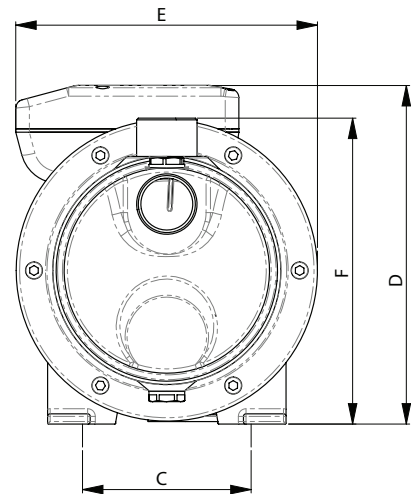
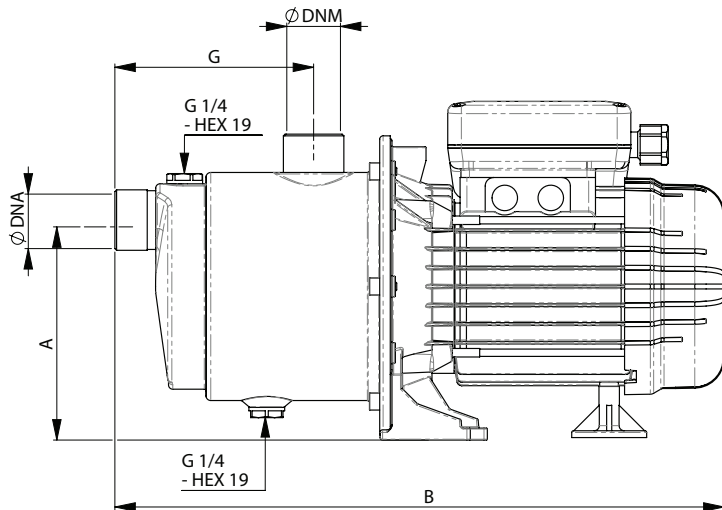

OVERALL DIMENSIONS AND WEIGHTS

MODEL	Dimensions mm.									Weight (Kg)
	A	B	C	D	E	F	G	DNA	DNM	
Multi EVO 3-30 M	129	356	100	199	177	180	116	1"	1"	6,7
Multi EVO 3-30 T	129	356	100	199	177	180	116	1"	1"	6,7
Multi EVO 3-40 M	129	356	100	199	177	180	116	1"	1"	7,1
Multi EVO 3-40 T	129	356	100	199	177	180	116	1"	1"	7,1
Multi EVO 3-50 M	129	400	100	207	177	180	139	1"	1"	9,1
Multi EVO 3-50 T	129	400	100	207	177	180	139	1"	1"	9,1
Multi EVO 3-60 M	129	422	100	207	177	180	161	1"	1"	10,8
Multi EVO 3-60 T	129	422	100	207	177	180	161	1"	1"	10,8

NOCCHI Multi EVO 5

CENTRIFUGAL MULTISTAGE ELECTRIC PUMPS

HYDRAULIC PERFORMANCE

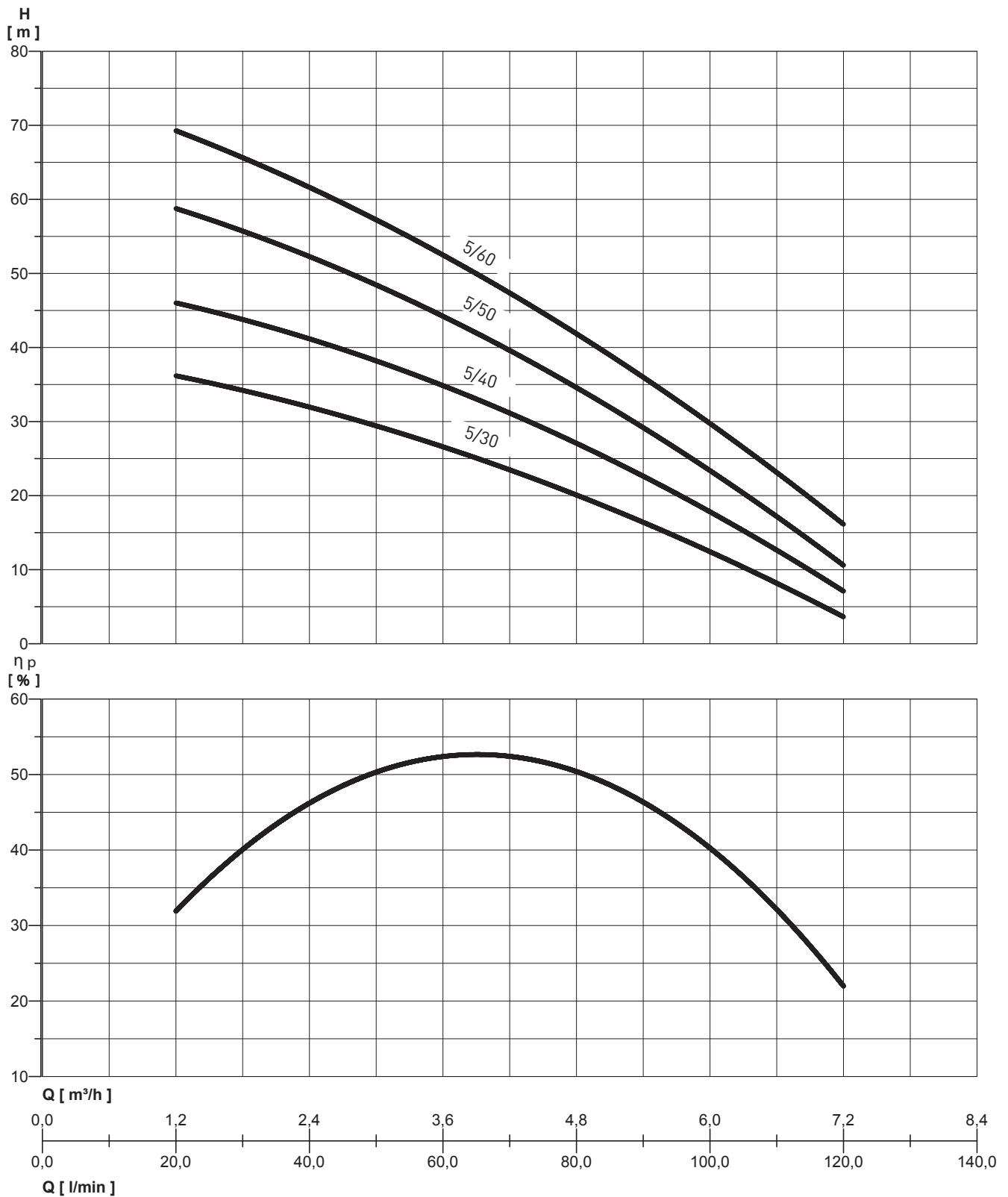

NOCCHI Multi EVO 5

CENTRIFUGAL MULTISTAGE ELECTRIC PUMPS

PERFORMANCE TABLE

MODEL	Nominal power (P2)		Absorbed power (P1)		Voltage (V)	In (A)	μF	Q	total head in metres water column							
	HP	kW	HP	kW					l/min	20	30	40	50	60	80	100
								m ³ /h	1,2	1,8	2,4	3	3,6	4,8	6	7,2
Multi EVO 5-30 M	0,75	0,55	1,1	0,8	1 ~ 230	3,7	12,5		36	34	32	30	27	19,5	12	4
Multi EVO 5-30 T	0,71	0,53	1,05	0,78	3 ~ 230/400	2,7 / 1,55	---		46	44	41	38	35	27	18	7
Multi EVO 5-40 M	1	0,75	1,5	1,1	1 ~ 230	4,7	16		58	56	53	49	44	34	23	11
Multi EVO 5-40 T	1	0,75	1,5	1,1	3 ~ 230/400	3,5 / 2	---		69	66	62	57	52	42	30	16
Multi EVO 5-50 M	1,27	0,95	1,8	1,35	1 ~ 230	6,2	20									
Multi EVO 5-50 T	1,2	0,9	1,68	1,25	3 ~ 230/400	3,7 / 2,1	---									
Multi EVO 5-60 M	1,6	1,2	2,2	1,65	1 ~ 230	7,5	31,5									
Multi EVO 5-60 T	1,6	1,2	2,1	1,57	3 ~ 230/400	5,3 / 3,1	---									

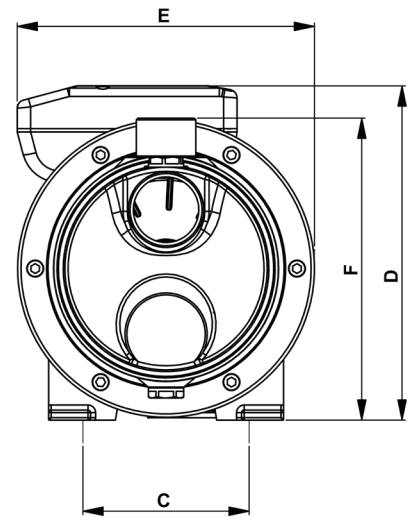
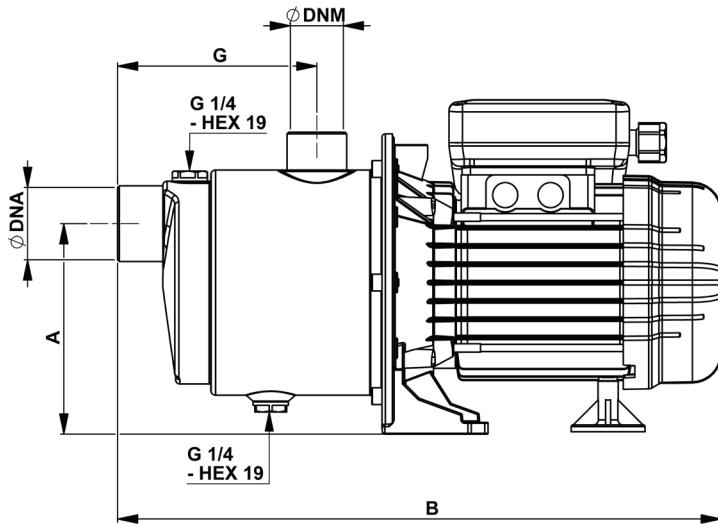

OVERALL DIMENSIONS AND WEIGHTS

MODEL	Dimensions mm.									Weight (Kg)
	A	B	C	D	E	F	G	DNA	DNM	
Multi EVO 5-30 M	125	360	100	199	177	180	119	1" 1/4	1"	7,1
Multi EVO 5-30 T	125	360	100	199	177	180	119	1" 1/4	1"	7,1
Multi EVO 5-40 M	125	380	100	207	177	180	119	1" 1/4	1"	8,8
Multi EVO 5-40 T	125	380	100	207	177	180	119	1" 1/4	1"	8,8
Multi EVO 5-50 M	125	402	100	207	177	180	142	1" 1/4	1"	10,4
Multi EVO 5-50 T	125	402	100	207	177	180	142	1" 1/4	1"	10,4
Multi EVO 5-60 M	125	457	100	215	203	180	164	1" 1/4	1"	13,5
Multi EVO 5-60 T	125	457	100	215	177	180	164	1" 1/4	1"	13,5

NOCCHI Multi EVO 8

CENTRIFUGAL MULTISTAGE ELECTRIC PUMPS

HYDRAULIC PERFORMANCE

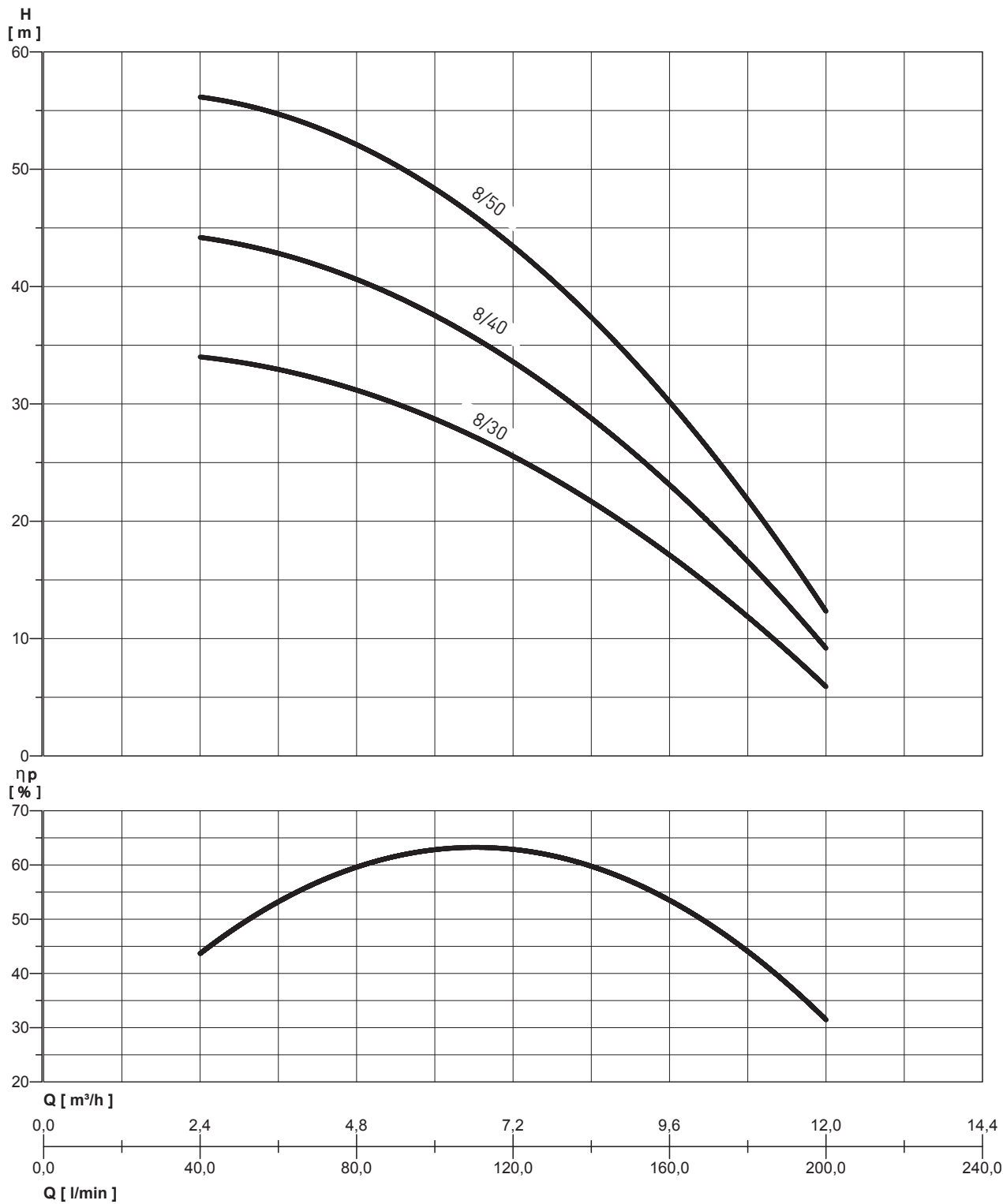

NOCCHI Multi EVO 8

CENTRIFUGAL MULTISTAGE ELECTRIC PUMPS

PERFORMANCE TABLE

MODEL	Nominal power (P2)		Absorbed power (P1)		Voltage (V)	In (A)	μF	Q	total head in metres water column											
	HP	kW	HP	kW					40	60	80	100	120	140	160	180	200			
									l/min	2,4	3,6	4,8	6	7,2	8,4	9,6	10,8	12		
Multi EVO 8-30 M	1,2	0,9	1,7	1,28	1 ~ 230	5,9	20	total head in metres water column												
Multi EVO 8-30 T	1,2	0,9	1,6	1,2	3 ~ 230/400	3,7 / 2,1	---		34	33,5	31	29	25,5	22	16,5	12	6			
Multi EVO 8-40 M	1,6	1,2	2,23	1,66	1 ~ 230	7,7	31,5		44,5	42,5	40,5	37,5	34	29	23	16	9,5			
Multi EVO 8-40 T	1,6	1,18	2	1,5	3 ~ 230/400	5 / 2,95	---		56,5	54,5	51,5	48,5	44	37,5	30	21,5	12,5			
Multi EVO 8-50 M	1,9	1,4	2,7	2	1 ~ 230	9	35													
Multi EVO 8-50 T	1,9	1,4	2,6	1,95	3 ~ 230/400	6,7 / 4	---													

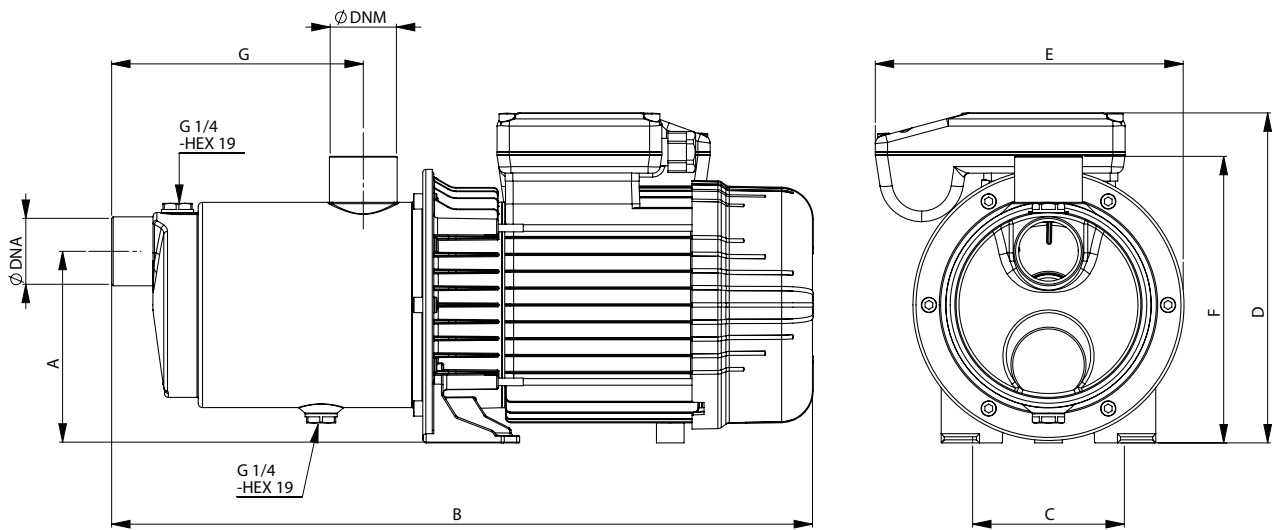

OVERALL DIMENSIONS AND WEIGHTS

MODEL	Dimensions mm.									Weight (Kg)
	A	B	C	D	E	F	G	DNA	DNM	
Multi EVO 8-30 M	125	398	100	207	177	187	137	1 1/4	1 1/4	10,5
Multi EVO 8-30 T	125	398	100	207	177	187	137	1 1/4	1 1/4	10,5
Multi EVO 8-40 M	125	430	100	215	203	187	137	1 1/4	1 1/4	13,4
Multi EVO 8-40 T	125	430	100	215	177	187	137	1 1/4	1 1/4	13,4
Multi EVO 8-50 M	125	457	100	215	203	187	164	1 1/4	1 1/4	14,5
Multi EVO 8-50 T	125	457	100	215	177	187	164	1 1/4	1 1/4	14,5